



Designation: E2938 – 15

# Standard Test Method for Evaluating the Relative-Range Measurement Performance of 3D Imaging Systems in the Medium Range<sup>1</sup>

This standard is issued under the fixed designation E2938; the number immediately following the designation indicates the year of original adoption or, in the case of revision, the year of last revision. A number in parentheses indicates the year of last reapproval. A superscript epsilon ( $\epsilon$ ) indicates an editorial change since the last revision or reapproval.

## 1. Scope

1.1 This standard describes a quantitative test method for evaluating the range measurement performance of laser-based, scanning, time-of-flight, *3D imaging systems* in the medium range. The term “medium range” refers to systems that are capable of operating within at least a portion of ranges from 2 to 150 m. The term “time-of-flight systems” includes phase-based, pulsed, and chirped systems. The word “standard” in this document refers to a *documentary standard* as per Terminology E284. This test method only applies to 3D imaging systems that are capable of producing a *point cloud* representation of a measured target.

1.1.1 As defined in Terminology E2544, a *range* is the distance measured from the origin of a 3D imaging system to a point in space. This range is often referred to as an absolute range. However, since the origin of many 3D imaging systems is either unknown or not readily measurable, a test method for absolute range performance is not feasible for these systems. Therefore, in this test method, the range is taken to be the distance between two points in space on a line that passes through the origin of the 3D imaging system. Although the error in the calculated distance between these two points is a *relative-range error*, in this test method when the term range error is used it refers to the relative-range error. This test method cannot be used to quantify the constant offset error component of the range error.

1.1.2 This test method recommends that the first point be at the manufacturer-specified *target 1 range* and requires that the second target be on the same side of the instrument under test (IUT) as the first target. Specification of *target 1 range* by the manufacturer minimizes the contribution to the relative range measurement error from the target 1 range measurement.

1.1.3 This test method may be used once to evaluate the IUT for a given set of conditions or it may be used multiple times to better assess the performance of the IUT for various conditions (for example, additional ranges, various reflectances, environmental conditions).

<sup>1</sup> This test method is under the jurisdiction of ASTM Committee E57 on 3D Imaging Systems and is the direct responsibility of Subcommittee E57.20 on Terrestrial Stationary Systems.

Current edition approved April 1, 2015. Published June 2015. DOI: 10.1520/E2938-15.

1.2 The values stated in SI units are to be regarded as standard. No other units of measurement are included in this standard. SI units are used for all calculations and results in this standard.

1.3 The method described in this standard is not intended to replace more in-depth methods used for instrument calibration or compensation, and specific measurement applications may require other tests and analyses.

1.4 *This standard does not purport to address all of the safety concerns, if any, associated with its use. It is the responsibility of the user of this standard to establish appropriate safety, health, and environmental practices and determine the applicability of regulatory limitations prior to use.* Some aspects of the safe use of 3D Imaging Systems are discussed in Practice ASTM E2641.

1.5 *This international standard was developed in accordance with internationally recognized principles on standardization established in the Decision on Principles for the Development of International Standards, Guides and Recommendations issued by the World Trade Organization Technical Barriers to Trade (TBT) Committee.*

## 2. Referenced Documents

2.1 *ASTM Standards:*<sup>2</sup>

E284 Terminology of Appearance

E1164 Practice for Obtaining Spectrometric Data for Object-Color Evaluation

E1331 Test Method for Reflectance Factor and Color by Spectrophotometry Using Hemispherical Geometry

E2544 Terminology for Three-Dimensional (3D) Imaging Systems

E2641 Practice for Best Practices for Safe Application of 3D Imaging Technology

2.2 *ASME Standards:*<sup>3</sup>

ASME B89.1.9-2002 Gage Blocks

<sup>2</sup> For referenced ASTM standards, visit the ASTM website, [www.astm.org](http://www.astm.org), or contact ASTM Customer Service at [service@astm.org](mailto:service@astm.org). For *Annual Book of ASTM Standards* volume information, refer to the standard's Document Summary page on the ASTM website.

<sup>3</sup> Available from American Society of Mechanical Engineers (ASME), ASME International Headquarters, Two Park Ave., New York, NY 10016-5990, <http://www.asme.org>.

**ASME B89.4.19-2006** Performance Evaluation of Laser-Based Spherical Coordinate Measurement Systems

**ASME B89.7.2-1999** Dimensional Measurement Planning

2.3 *ISO Standards*.<sup>4</sup>

**ISO 14253-1:1998** Geometrical Product Specifications (GPS)—Inspection by measurement of workpieces and measuring equipment—Part 1: Decision rules for proving conformance or non-conformance with specifications

**ISO 14253-2:1999** Geometrical Product Specifications (GPS)—Inspection by measurement of workpieces and measuring equipment—Part 2: Guide to the estimation of uncertainty in GPS measurement, in calibration of measuring equipment and in product verification

2.4 *JCGM Standards*:

**JCGM 200:2012** International vocabulary of metrology—Basic and general concepts and associated terms (VIM), 3rd edition

**JCGM 100:2008** Evaluation of measurement data—Guide to the expression of uncertainty in measurement (GUM), 1st edition

### 3. Terminology

#### 3.1 Definitions:

3.1.1 *3D imaging system, n*—a non-contact measurement instrument used to produce a 3D representation (for example, a point cloud) of an object or a site. **E2544**

3.1.1.1 *Discussion*—Some examples of a 3D imaging system are laser scanners (also known as LADARs or LIDARs or laser radars), optical range cameras (also known as flash LIDARs or 3D range cameras), triangulation-based systems such as those using pattern projectors or lasers, and other systems based on interferometry.

3.1.1.2 *Discussion*—In general, the information gathered by a 3D imaging system is a collection of  $n$ -tuples, where each  $n$ -tuple can include but is not limited to spherical or Cartesian coordinates, return signal strength, color, time stamp, identifier, polarization, and multiple range returns.

3.1.1.3 *Discussion*—3D imaging systems are used to measure from relatively small scale objects (for example, coin, statue, manufactured part, human body) to larger scale objects or sites (for example, terrain features, buildings, bridges, dams, towns, archeological sites).

3.1.2 *calibration, n*—operation that, under specified conditions, in a first step, establishes a relation between the quantity values with measurement uncertainties provided by measurement standards and corresponding indications with associated measurement uncertainties and, in a second step, uses this information to establish a relation for obtaining a measurement result from an indication. **JCGM 200:2012 (VIM) – 2.39**

3.1.3 *combined standard uncertainty, n*—standard uncertainty of the result of a measurement when that result is obtained from the values of a number of other quantities, equal to the positive square root of a sum of terms, the terms being the variances or covariances of these other quantities weighted

according to how the measurement result varies with changes in these quantities. **JCGM 100:2008 (GUM) – 2.3.4**

3.1.4 *compensation, n*—the process of determining systematic errors in an instrument and then applying these values in an error model that seeks to eliminate or minimize measurement errors. **ASME B89.4.19**

3.1.5 *covariance*—the covariance of two random variables is a measure of their mutual dependence. **JCGM 100:2008 (GUM) – C.3.4**

3.1.6 *coverage factor, n*—numerical factor used as a multiplier of the combined standard uncertainty in order to obtain an expanded uncertainty.

3.1.6.1 *Discussion*—A coverage factor,  $k$ , is typically in the range 2 to 3. **JCGM 100:2008 (GUM) 2.3.6**

3.1.7 *diffuse reflectance factor,  $R_d$ , n*—the ratio of the flux reflected at all angles within the hemisphere bounded by the plane of measurement except in the direction of the specular reflection angle, to the flux reflected from the perfect reflecting diffuser under the same geometric and spectral conditions of measurement. **E284 Section 3.1**

3.1.7.1 *Discussion*—The size of the specular reflection angle depends on the instrument and the measurement conditions used. For its precise definition the make and model of the instrument or the aperture angle or aperture solid angle of the instrument or the aperture angle or aperture solid angle of the specularly reflected beam should be specified.

3.1.8 *documentary standard, n*—document, arrived at by open consensus procedures, specifying necessary details of a method of measurement, definitions of terms, or other practical matters to be standardized. **E284**

3.1.9 *expanded test uncertainty, n*—product of a combined standard measurement uncertainty and a factor larger than the number one. **JCGM 200:2012 (VIM) – 2.35**

3.1.10 *flatness, n*—the minimum distance between two parallel planes between which all points of the measuring face lie. **ASME B89.1.9 – 3.5**

3.1.11 *limiting conditions, n*—the manufacturer’s specified limits on the environmental, utility, and other conditions within which an instrument may be operated safely and without damage. **ASME B89.4.19**

3.1.11.1 *Discussion*—The manufacturer’s performance specifications are not assured over the limiting conditions.

3.1.12 *maximum permissible error (MPE), n*—extreme value of measurement error, with respect to a known reference quantity value, permitted by specifications or regulations for a given measurement, measuring instrument, or measuring system. **JCGM 200:2012 (VIM) – 4.26**

3.1.12.1 *Discussion*—Usually, the term “maximum permissible errors” or “limits of error” is used where there are two extreme values.

3.1.12.2 *Discussion*—The term “tolerance” should not be used to designate ‘maximum permissible error’.

3.1.13 *measurand, n*—quantity intended to be measured. **JCGM 200:2012 (VIM) – 2.3**

3.1.13.1 *Discussion*—The specification of a measurand requires knowledge of the kind of quantity, description of the

<sup>4</sup> Available from American National Standards Institute (ANSI), 25 W. 43rd St., 4th Floor, New York, NY 10036, <http://www.ansi.org>.

state of the phenomenon, body, or substance carrying the quantity, including any relevant component, and the chemical entities involved.

3.1.13.2 *Discussion*—In the second edition of the VIM and in IEC 60050-300:2001, the measurand is defined as the ‘quantity subject to measurement’.

3.1.13.3 *Discussion*—The measurement, including the measuring system and the conditions under which the measurement is carried out, might change the phenomenon, body, or substance such that the quantity being measured may differ from the measurand as defined. In this case, adequate correction is necessary.

Example 1—The potential difference between the terminals of a battery may decrease when using a voltmeter with a significant internal conductance to perform the measurement. The open-circuit potential difference can be calculated from the internal resistances of the battery and the voltmeter.

Example 2—The length of a steel rod in equilibrium with the ambient Celsius temperature of 23°C will be different from the length at the specified temperature of 20°C, which is the measurand. In this case, a correction is necessary.

3.1.13.4 *Discussion*—In chemistry, “analyte”, or the name of a substance or compound, are terms sometimes used for ‘measurand’. This usage is erroneous because these terms do not refer to quantities.

3.1.14 *measurement accuracy, n*—closeness of agreement between a measured quantity value and a true quantity value of a measurand. **JCGM 200:2012 (VIM) – 2.13**

3.1.14.1 *Discussion*—The concept ‘measurement accuracy’ is not a quantity and is not given a numerical quantity value. A measurement is said to be more accurate when it offers a smaller measurement error.

3.1.14.2 *Discussion*—The term “measurement accuracy” should not be used for measurement trueness and the term measurement precision should not be used for ‘measurement accuracy’, which, however, is related to both these concepts.

3.1.14.3 *Discussion*—‘Measurement accuracy’ is sometimes understood as closeness of agreement between measured quantity values that are being attributed to the measurand.

3.1.15 *measurement error, n*—measured quantity value minus a reference quantity value. **JCGM 200:2012 (VIM) – 2.16**

3.1.15.1 *Discussion*—The concept of ‘measurement error’ can be used both: (1) when there is a single reference quantity value to refer to, which occurs if a calibration is made by means of a measurement standard with a measured quantity value having a negligible measurement uncertainty or if a conventional quantity value is given, in which case the measurement error is known; and (2) if a measurand is supposed to be represented by a unique true quantity value or a set of true quantity values of negligible range, in which case the measurement error is not known.

3.1.15.2 *Discussion*—Measurement error should not be confused with production error or mistake.

3.1.16 *measurement uncertainty, n*—non-negative parameter characterizing the dispersion of the quantity values being attributed to a measurand, based on the information used. **JCGM 200:2012 (VIM) – 2.26**

3.1.16.1 *Discussion*—Measurement uncertainty includes

components arising from systematic effects, such as components associated with corrections and the assigned quantity values of measurement standards, as well as the definitional uncertainty. Sometimes estimated systematic effects are not corrected for but, instead, associated measurement uncertainty components are incorporated.

3.1.16.2 *Discussion*—The parameter may be, for example, a standard deviation called standard measurement uncertainty (or a specified multiple of it), or the half-width of an interval, having a stated coverage probability.

3.1.16.3 *Discussion*—Measurement uncertainty comprises, in general, many components. Some of these may be evaluated by Type A evaluation of measurement uncertainty from the statistical distribution of the quantity values from series of measurements and can be characterized by standard deviations. The other components, which may be evaluated by Type B evaluation of measurement uncertainty, can also be characterized by standard deviations, evaluated from probability density functions based on experience or other information.

3.1.16.4 *Discussion*—In general, for a given set of information, it is understood that the measurement uncertainty is associated with a stated quantity value attributed to the measurand. A modification of this value results in a modification of the associated uncertainty.

3.1.17 *point cloud, n*—a collection of data points in 3D space (frequently in the hundreds of thousands), for example as obtained using a 3D imaging system. **E2544**

3.1.17.1 *Discussion*—The distance between points is generally non-uniform and hence all three coordinates (Cartesian or spherical) for each point must be specifically encoded.

3.1.18 *range, n*—the distance, in units of length, between a point in space and an origin fixed to the 3D imaging system that is measuring that point. **E2544**

3.1.18.1 *Discussion*—In general, the origin corresponds to the instrument origin.

3.1.19 *rated conditions, n*—manufacturer-specified limits on environmental, utility, and other conditions within which the manufacturer’s performance specifications are guaranteed at the time of installation of the instrument. **ASME B89.4.19**

3.1.20 *repeatability (of results of measurements), n*—closeness of the agreement between the results of successive measurements of the same measurand carried out under the same conditions of measurement. **JCGM 200:2012 (VIM) – 3.6**

3.1.20.1 *Discussion*—These conditions are called repeatability conditions.

3.1.20.2 *Discussion*—Repeatability conditions include: the same measurement procedure; the same observer; the same measuring instrument used under the same conditions; the same location; and repetition over a short period of time.

3.1.20.3 *Discussion*—Repeatability may be expressed quantitatively in terms of the dispersion characteristics of the results.

3.1.21 *reflectance, n*—ratio of the reflected radiant or luminous flux to the incident flux in the given conditions. **E284**

### Section 3.1

3.1.21.1 *Discussion*—The term reflectance is often used in a

general sense or as an abbreviation for reflectance factor. Such usage may be assumed unless the above definition is specifically required by context.

3.1.22 *reflectance factor, n*—ratio of the flux reflected from the specimen to the flux reflected from the perfect reflecting diffuser under the same geometric and spectral conditions of measurement. **E284 Section 3.1**

3.1.23 *target, n*—an object to be measured. **ASME B89.7.2-1999**

3.1.24 *uncertainty budget, n*—statement summarizing the estimation of the uncertainty components that contributes to the uncertainty of a result of a measurement. **ISO 14253-2:1999**

3.1.25 *variance*—the variance of a random variable is the expectation of its quadratic deviation about its expectation. **JCGM 100:2008 (GUM) – C.3.2**

## 3.2 Definitions of Terms Specific to This Standard:

3.2.1 *IUT, n*—instrument under test.

3.2.2 *maximum permissible relative-range error,  $R_{MPE}$ , n*—extreme value of the relative-range error, expressed in units of length, permitted by specifications or regulations for a 3D imaging system.

3.2.2.1 *Discussion*—The maximum permissible value of the relative-range error,  $R_{MPE}$ , can be expressed as:

$R_{MPE}$  = minimum of  $(A + B*L)$  and  $C$ , or

$R_{MPE}$  =  $(A + B*L)$ , or

$R_{MPE}$  =  $C$

where:

$A$  and  $C$  are positive constants, expressed in millimeters and supplied by the manufacturer;

$B$  is a dimensionless positive constant supplied by the manufacturer; and

$L$  is equal to the *target 2 range*, in millimeters (distance from the origin of the 3D imaging system to Target 2).

Different values for  $A$ ,  $B$ , and  $C$  may be provided by the manufacturer for different range intervals for the IUT.

3.2.3 *relative-range error, n*—the difference in the distance between two points measured by an instrument and the reference distance between the same points, where the points are on the same side of the instrument and lie on a line that passes through the origin of the instrument.

3.2.3.1 *Discussion*—The relative-range error does not include the error caused by any constant offset between the optical and mechanical origins of the instrument. Any constant offsets in the two range measurements will cancel each other when the relative range is calculated. This offset is sometimes referred to as the  $R_0$  error.

3.2.4 *target 1 range, n*—the range, as specified by the 3D imaging instrument manufacturer, from the IUT to the first target used in this standard.

3.2.4.1 *Discussion*—The *target 1 range* will usually be the range from the IUT at which the error in the range measurement is minimized.

3.2.4.2 *Discussion*—The *target 1 range* is not necessarily the same as the minimum range specified by the manufacturer, but may be close to it.

3.2.4.3 *Discussion*—Since the origin of a 3D imaging system is either unknown or not readily measurable in many cases, a user may not be able to place Target 1 at the *target 1 range* with a known error. Thus, the *target 1 range* is a nominal value that represents the approximate distance from the origin of the IUT at which Target 1 should be placed.

3.2.5 *target 2 range, n*—the range, as chosen by the person conducting this test, from the IUT to the second target used in this standard.

3.2.5.1 *Discussion*—The *target 2 range* must be between (or at) the minimum and maximum ranges of the IUT, as specified by the manufacturer.

3.2.5.2 *Discussion*—Since the origin of a 3D imaging system is either unknown or not readily measurable in many cases, a user may not be able to place Target 2 at the *target 2 range* with a known error. Thus, the *target 2 range* is a nominal value that represents the approximate distance from the origin of the IUT at which Target 2 should be placed.

## 4. Significance and Use

4.1 This standard provides a test method for obtaining the range error for medium-range 3D imaging systems. The results from this test method may be used to evaluate or to verify the range measurement performance of medium-range 3D imaging systems. The results from this test method may also be used to compare performance among different instruments.

4.2 The range performance of the IUT obtained by the application of this test method may be different from the range performance of the IUT under some real-world conditions. For example, object geometry, texture, temperature and reflectance as well as vibrations, particulate matter, thermal gradients, ambient lighting, and wind in the environment will affect the range performance.

4.3 The test may be carried out for instrument acceptance, warranty or contractual purposes by mutual agreement between the manufacturer and the user. The IUT is tested in accordance with manufacturer-supplied specifications, rated conditions, and technical documentation. This test may be repeated for any *target 2 range* within the manufacturer's specifications and for any rated conditions.

4.4 For the purposes of understanding the behavior of the IUT and without warranty implications, this test may be modified as necessary to characterize the range measurement performance of the IUT outside the manufacturer's rated conditions, but within the manufacturer's limiting conditions.

4.5 The manufacturer may provide different values for the specifications for different sets of rated conditions, for example, better range measurement performance might be specified under a set of more restrictively rated environmental conditions. The user is advised that the IUT's performance may differ significantly in other modes of operation or outside the rated conditions and should inquire with the manufacturer for specifications of the mode that best represents the planned usage. If a target other than that described in Section 7, or if procedures other than those described in Section 8 are used, additional analysis not covered in this test method may be required.

5. Introduction

5.1 This standard involves measuring the distance between the centers of two flat target plates that are nominally parallel to each other by scanning them with the IUT (see Note 1). Line A, as shown in Fig. 1, is a virtual line that passes through the geometrical centers of the front sides of the two target plates. The two target plates are oriented so that their front surfaces are perpendicular to Line A. Line A should ideally go through the origin of the IUT in order to minimize the contribution of any angular errors to the range error. If Line A does not go through the origin of the IUT, any offset distance of the origin of the IUT from Line A should be minimized (see Appendix X2). The distance between the two target plates as measured by the IUT is then compared to the corresponding distance (a reference distance) measured using a reference instrument and the difference between them is defined as the range error (see Note 2). This range error is the metric used to quantify the relative-range measurement performance of the IUT.

NOTE 1—The user may use either the same physical flat target plate to represent both Target 1 and Target 2 or may use two different physical flat target plates.

NOTE 2—Because the range is calculated as the distance between two points, the R0 error cancels out and cannot be determined using this test method. Appendix X2, Section X2.2.11 describes the R0 error.

6. Test Conditions and Requirements

6.1 Rated Conditions:

6.1.1 The rated conditions should be provided by the manufacturer. Recommended rated conditions include target 1 range, minimum and maximum ranges, target characteristics (7.1), minimum and maximum temperatures, and thermal gradient (°C/m and °C/h). If any rated condition is not specified, then it is assumed that the test will be valid for any range of that condition.

6.1.2 The conditions of the test environment must remain within the bounds of the manufacturer’s rated conditions throughout the test.

6.2 Operating Modes:

6.2.1 Operating modes for an instrument typically define the instrument settings such as point spacing, scanning acquisition rate, and integration time. The manufacturer must state the operating modes under which the specified performance values are valid. Operating modes must be available to the user and must be clearly described so that they can be reproduced by any qualified user (see Note 3).

6.2.2 The IUT shall be operated in accordance with the procedures given in the manufacturer’s User Manual. All applicable procedures described in the manufacturer’s User Manual for the proper use of the instrument, such as machine startup/warm-up, compensation procedures and manufacturer maintenance requirements, shall be adhered to.

NOTE 3—A qualified user is a person who has been trained in the proper use of the IUT.

6.3 Target Location Requirements:

6.3.1 For the purposes of comparing the range measurement performance of the IUT with the manufacturer’s specifications, Target 1 shall be placed at the target 1 range specified by the manufacturer. If the target 1 range is not specified by the manufacturer, the user may select any range between and including the minimum range and the maximum range of the IUT. In the case where the manufacturer specifies a target 1 range, and the user does not choose to use it, then the IUT’s range measurement performance may differ from the manufacturer’s specifications.

6.3.2 For the purposes of understanding the behavior of the IUT and without warranty implications, the user may select any range between and including the minimum range and the maximum range of the IUT for Target 1.

6.3.3 Target 1 and Target 2 shall be located on the same side of the IUT so that the normals of the front face of both targets are pointing in the same direction and toward the IUT (as shown in Fig. 1).

6.3.4 Target 2 shall be located between (or at) the minimum and maximum ranges of the IUT, as specified by the manufacturer, and may be located closer to the IUT than Target 1.

6.4 Test Uncertainty:

6.4.1 An estimate of the errors associated with the limitations in the present test method to properly evaluate the relative-range measurement performance of the IUT is called the test uncertainty. This is the uncertainty of the calculated range error ( $E_{range}$  in Section 10.1) of the IUT.

6.4.2 In this test method, the expanded test uncertainty,  $U$ , is equal to two times the combined standard uncertainty (that is, a coverage factor,  $k = 2$ ).

NOTE 4—According to ISO 14253-1, Section 4, by default the coverage factor is  $k = 2$ .

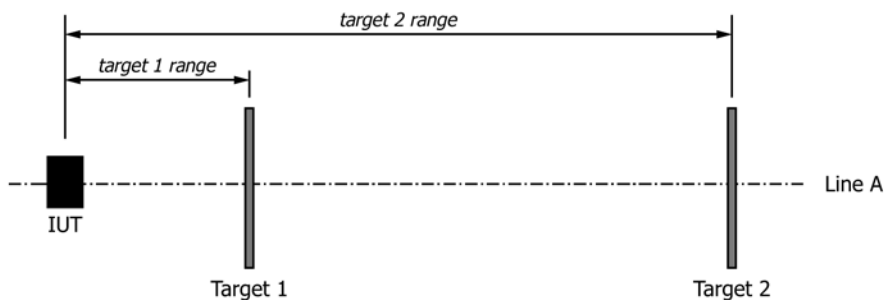

FIG. 1 Top View Showing the IUT and the Position and Orientation of the Target Plates Relative to the IUT

6.4.3  $U$  must be less than or equal to  $\frac{1}{4}$  (simple 4:1 decision rule) of the *maximum permissible range error*,  $R_{MPE}$ , which shall be specified by the manufacturer of the IUT. See [Appendix X2](#) for an example of how to calculate  $U$ .

NOTE 5—Industry practice is to use a simple 4:1 decision rule ratio of MPE to expanded uncertainty. For example, Section 6.2 of ASME B89.4.19-2006 standard specifies that the expanded uncertainty of the reference length should not exceed one quarter of the MPE of the IUT to obtain a measurement capability index,  $C_m = \frac{MPE}{U}$ , of 4.

**7. Apparatus**

7.1 *Target*—The target is a flat plate with optical and mechanical requirements determined by the expected performance of the IUT as discussed below. The target may be square, rectangular, circular or any other shape for which a boundary is easily defined. However, for illustration purposes, a square- or rectangular-shaped target is assumed throughout this document.

7.1.1 *Optical Requirements:*

7.1.1.1 Different materials have different optical characteristics such as *reflectance*, optical penetration depth (volumetric scattering), color, and surface scattering characteristics, which means that the values of the measured range errors may differ for different materials. Materials that may be used for the target include, but are not limited to, ceramic, steel and aluminum. One candidate target is constructed of aluminum with a vapor-blasted surface finish.

7.1.1.2 The types of target materials, and their optical characteristics (for example, target *reflectance*), used in the test should be specified by the manufacturer. If a material other than that specified by the manufacturer is used, the performance of the IUT using this material may not meet the manufacturer’s specifications. If the target material is not specified by the manufacturer, the user is free to use any material for the test. It is recommended that the manufacturer use target materials for the testing that may be obtained at a reasonable cost to the user.

7.1.1.3 The *reflectance factor* of the target surface as measured in accordance with Practice [E1164](#) and Test Method [E1331](#) must be within the manufacturer’s specifications. It is strongly recommended that the *reflectance factor* with and without the specular component be reported, if possible. If the *reflectance factor* is not specified by the manufacturer, the user is free to use any *reflectance factor* for the test.

NOTE 6—The *reflectance factor* consists of both diffuse and specular

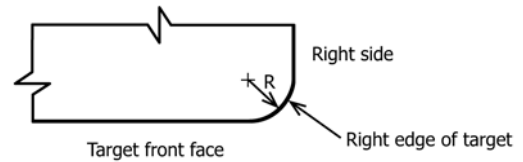

**FIG. 2 The Target Edge Radius**

components, while the *diffuse reflectance factor* excludes the specular component.

7.1.2 *Mechanical Requirements:*

7.1.2.1 The minimum target plate size should be specified by the manufacturer, and must be sufficient to yield a minimum of 100 points after point selection (see [9.2](#)). The front side of the target plate shall consist of a single surface made of a single material. The edges of the target shall have a radius ( $R$  in [Fig. 2](#)) of less than or equal to one quarter ( $\frac{1}{4}$ ) of the smallest *beam width* of the IUT.

7.1.2.2 The *flatness* of the target plate shall not exceed 20 % of the MPE of the range error of the IUT at the relevant target range. The flatness should be measured in accordance with the procedures in Section 5.4.2 of ASME Y14.5.1M-1994-R2009.

7.1.3 *Mounting:*

7.1.3.1 The target plate shall be rigidly mounted on stable supports and the front surface of the target plate shall be unobstructed. In addition, any part of the target plate support that is visible to the IUT should be sufficiently separated from the target plate so that any measured points on the support may be easily removed in the data segmentation in [9.1](#). [Fig. 3](#) shows examples of acceptable and unacceptable configurations of the target plate support.

7.1.4 *Alignment:*

7.1.4.1 The required quality of the target plate and IUT alignment (position and orientation with respect to Line A) is primarily determined by the specifications of the IUT. Acceptable alignment criteria need to be determined by conducting an uncertainty analysis for the specific test setup and IUT utilized. An example of how to determine the uncertainty budget for the specific test setup given in “[Appendix X1 – Example Procedure](#)” is provided in “[Appendix X2 – Assessing Test Uncertainty](#).”

7.2 *Reference Instrument*—The reference instrument shall measure the reference distance with an expanded uncertainty ( $k = 2$ ) less than that of the manufacturer-specified *maximum permissible range error*,  $R_{MPE}$ , of the IUT. The choice of reference instrument should be such that its MPE would result

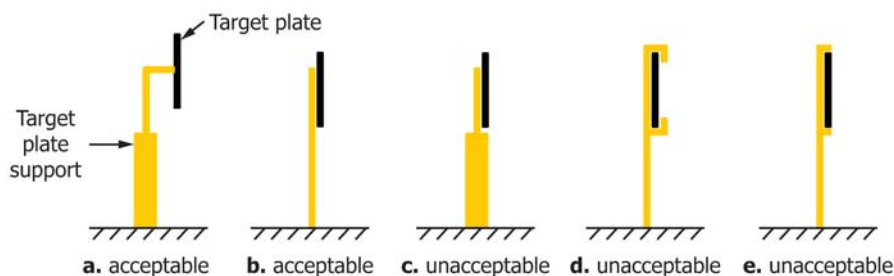

**FIG. 3 The Target Plate Supports shown in (a) and (b) will Meet the Requirement in this Section whereas the Target Plate Supports Shown in (c), (d) and (e) Will Not Meet the Requirement**

in an expanded test uncertainty,  $U$  (as described in Appendix X2 – Assessing Test Uncertainty), that is in conformance with 6.4. The reference instrument shall be maintained and used in accordance with the manufacturer’s instructions.

**8. Test Procedure**

8.1 The test procedure for acquiring data consists of the steps outlined below; however, the sequence of the steps may differ from one test to another depending on the specific test requirements. A schematic of an example experimental setup is shown in Fig. 1. Appendix X1 describes one way in which the test procedure may be implemented.

8.1.1 Set up Target 1 at target 1 range and Target 2 at target 2 range and ensure that there are no objects (other than the target supports) within 1 m of either Target 1 or Target 2. Target 1 and Target 2 may or may not be set up at the same time.

8.1.2 Align the front surfaces of the target plates so that they are as perpendicular as possible to the line that connects their geometrical centers (Line A) according to 7.1.4.

8.1.3 Align the IUT (as shown in Fig. 1) in order to minimize the offset distance of the origin (center of rotation) of the IUT from Line A according to 7.1.4.

8.1.4 Measure the distance,  $L_{ref}$ , between the geometrical centers of the target plates with the reference instrument. The method used for calculating  $L_{ref}$  will vary depending on the reference instrument and targets used, and is left to the user.

8.1.5 Scan each target plate with the IUT using the same operating mode settings for all scans, ensuring that the IUT scans beyond the edges of the target plate. The operating mode settings shall be chosen to yield, after point selection per 9.2, a minimum of 100 measured points within the point selection region. An image (or screen capture), from the point of view of the IUT, showing the distribution of the data on each target plate shall be provided as part of the report.

8.1.6 Repeat the above steps three times under the same repeatability conditions for a total of three repetitions and report the results for all repetitions. Scanning the same target three times consecutively is not considered three repetitions.

NOTE 7—Target 1 may need to be removed in order to be able to scan

Target 2 with the IUT. Alternatively, the same physical target may be scanned at target 1 range and at target 2 range sequentially if appropriate.

NOTE 8—Ensure that the points on the target can be clearly distinguished from the background. This may require that nearby objects be 1 m or more from the target and that highly reflective surfaces in the field of view of the IUT be removed or covered.

**9. Determination of Target Plate Centers**

NOTE 9—This section describes the steps required to determine the geometric centers of Target 1 and Target 2 using the measured points obtained from the IUT. Details of the procedure can be found in the subsequent sections and a summary of the steps is as follows: (1) Eliminate from the IUT data set all those measured points that are part of the background, surroundings, and target plate supports (9.1). (2) Select measured points that will be used for the plane fit by omitting the measured points that are in the edge exclusion regions (9.2). (3) Fit planes and calculate the standard deviations of the residuals (9.3). (4) Eliminate measured points on the target plates for which the magnitude of the residuals are greater than twice the standard deviation of the residuals of the plane fit (9.4). (5) Determine the geometric centers of the target plates (9.5).

**9.1 First Data Segmentation:**

9.1.1 For the purposes of analysis, measured points from the target plate may be manually segmented from measured points from other sources such as from the background and the target plate support using data manipulation software. This manual segmentation may be achieved using the best available method such as visual identification of the boundaries of the target plate from the intensity image.

9.1.2 Measured points collected from the target plate shall not be removed or filtered out. The resulting set of points for each target plate shall be called Point Set A1 for Target 1 and Point Set A2 for Target 2.

**9.2 Selection of Points on the Target Plate for Fitting a Plane:**

9.2.1 Measured points from a region within the target plate and away from the edges of the target plate shall be selected from Point Sets A1 and A2 for fitting a plane in 9.3. This point selection region shall not include measured points within the exclusion regions near the edges of the target plate. The widths of the exclusion regions shall be provided by the manufacturer and may differ along the two scan axes. The widths,  $a$  and  $b$ ,

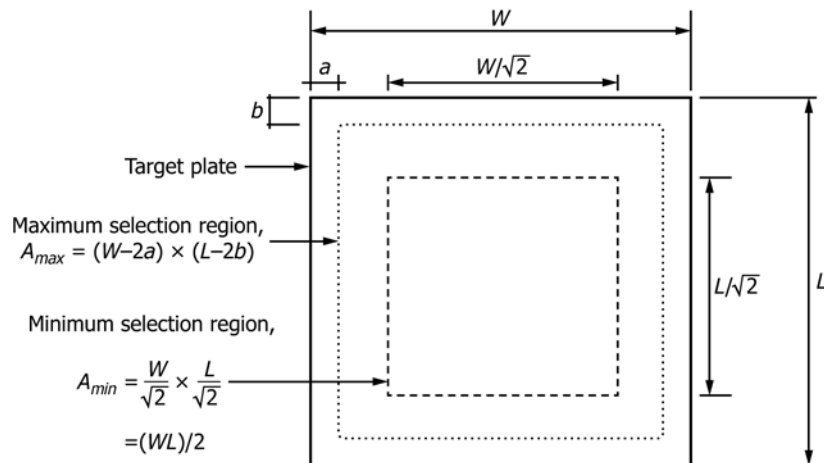

FIG. 4 A Schematic of a Target Plate having Dimensions  $W \times L$  Showing the Selection Regions and the Widths  $a$  and  $b$  of the Exclusion Region

of the exclusion regions shall be measured parallel to the edges of the target plate (see Fig. 4). In the absence of information from the manufacturer about the widths of the exclusion regions, the widths shall be set equal to (or greater than) the laser beam width at the target plate location.

NOTE 10—Measured points close to the edges of the targets may introduce an additional error into the plane fit due to phenomena such as multiple returns; therefore, those measured points shall not be used in the plane fit.

NOTE 11—The selection of measured points for the plane fit may be done visually or computationally.

9.2.2 The point selection region shall:

9.2.2.1 Cover 50 % of the target plate area, at a minimum, but should not exceed the maximum selection region, as shown in Fig. 4.

9.2.2.2 Have a height and width no smaller than 10 times the IUT laser beam width at the target plate location.

9.2.2.3 Be nominally centered on the target plate.

9.2.2.4 Contain at least 100 points.

9.2.3 The resulting set of points for each target plate shall be called Point Set B1 for Target 1 and Point Set B2 for Target 2.

9.2.4 Once the selection region is defined, all measured points that fall within that point selection region must be included in Point Set B1 for Target 1 and Point Set B2 for Target 2, respectively, and no points shall be manually or computationally removed or filtered from that selection region.

9.3 *Fit of a Plane to the Target Plate Data:*

9.3.1 For each Point Set B1 and Point Set B2 as defined in 9.2, a plane is fit to estimate the front surface of the corresponding target plate. The plane fitting method shall use all points in the point set and shall not, to the best knowledge of the user, eliminate any of the points during the fitting process. Where possible the plane fitting method should minimize the residual error in a total least-squares sense.<sup>5</sup> If the user cannot determine which plane fitting method is being used or if they choose to use a different plane fitting method, this must be reported. Record the standard deviations,  $s_1$  and  $s_2$ , of the residuals of the plane fits for Target 1 and Target 2, respectively.

9.4 *Second Data Segmentation:*

9.4.1 For each of Point Set A1 and Point Set A2 (see 9.1), eliminate points for which the magnitudes of the residuals are greater than  $2s_1$  and  $2s_2$  (from 9.3), respectively. The residuals are the orthogonal distances of all measured points in each point set to its respective plane determined in 9.3.

9.4.2 The resulting set of points for each target plate shall be called Point Set C1 for Target 1 and Point Set C2 for Target 2. Point Set C1 and Point Set C2 represent approximately 95 % of all measured points on Target 1 and Target 2, respectively.

9.5 *Determination of the Geometric Target Plate Center:*

9.5.1 The target plate centers of Target 1 and Target 2 are determined by performing the following steps using Point Set C1 and Point Set C2, respectively (as defined in 9.4):

9.5.1.1 Find the best estimate of the geometric centers of Target 1 and Target 2. Methods for estimating the geometric

centers may be 2D or 3D methods. These methods include, but are not limited to, using 2D bounding rectangles, 3D bounding boxes, 2D or 3D convex hulls, centroids, or intersections of diagonals. The method used to estimate the geometric centers will generate centers that are offset from the true geometric centers of the targets (the offsets are  $e_1$  and  $e_2$  in Appendix X2). The user shall estimate  $e_1$  and  $e_2$  and include them in the calculation of the test uncertainty.

9.5.1.2 If the method used to estimate the geometric centers in Step 1 is a 2D method, then the resulting geometric centers are the geometric centers of the targets. If the method used to estimate the geometric centers in Step 1 is a 3D method, then the resulting geometric centers must be projected onto the respective planes obtained in 9.3. The resulting projected coordinates are the geometric centers of the targets.

9.5.2 The geometric centers of Target 1 and Target 2 will have coordinates  $(x_1, y_1, z_1)$  and  $(x_2, y_2, z_2)$ , respectively.

## 10. Calculation and Interpretation of the Results

10.1 *Range Error:*

10.1.1 The range error,  $E_{range}$ , is:

$$E_{range} = L_{meas} - L_{ref} \quad (1)$$

where  $L_{ref}$  is the distance between the centers of the two target plates as obtained by the reference instrument, and  $L_{meas}$  is the distance between the centers of the two target plates as determined in 9.5, and is calculated as follows:

$$L_{meas} = \sqrt{(x_1 - x_2)^2 + (y_1 - y_2)^2 + (z_1 - z_2)^2} \quad (2)$$

10.1.2 If  $|E_{range}| \leq R_{MPE}$  as specified by the manufacturer, then the IUT is in conformance with the manufacturer specifications.

10.1.3 If  $|E_{range}| > R_{MPE}$  as specified by the manufacturer, then the IUT is not in conformance with the manufacturer specifications.

10.1.4 The range error calculation (10.1.1) shall be performed for each of the three repetitions per Section 8.

10.2 *RMS Dispersion:*

10.2.1 The user shall report the dispersion of the residuals based on a least-squares fit to a plane for both Point Set C1 and Point Set C2. The dispersion shall be reported as the RMS dispersion,  $RMS_1$  and  $RMS_2$ , for Target 1 and Target 2, respectively. The RMS dispersions,  $RMS_1$  and  $RMS_2$ , are found by calculating the square root of the average squared residual for Point Set C1 and Point Set C2, respectively. In general, the RMS is calculated as:

$$RMS = \sqrt{\frac{\sum_{i=1}^N d_i^2}{N}} \quad (3)$$

where:

$d_i$  = residual distance of measured point  $i$  to the plane determined in 9.3, and

$N$  = total number of measured points in Point Set C1 for  $RMS_1$  or Point Set C2 for  $RMS_2$ .

<sup>5</sup> Golub, Gene H., and Van Loan, Charles F., "An Analysis of the Total Least Squares Problem," *SIAM Journal on Numerical Analysis*, 17.6, 1980, pp. 883-893.



10.2.2 The RMS dispersion may be used as an indication of the expected measurement dispersion of the IUT when measuring the target material used in this test under the same test conditions.

### 10.3 Acceptance Criteria:

10.3.1 If the range errors are in conformance for all three repetitions, then the IUT is considered to be in conformance with the manufacturer specifications. If any of the range errors for any of the three repetitions is not in conformance, then the IUT is considered to not be in conformance with the manufacturer specifications.

## 11. Report

NOTE 12—An example of a reporting form is given in [Appendix X3](#).

### 11.1 Mandatory Reporting:

11.1.1 The following information about the test conditions shall be reported:

11.1.1.1 Test date (month/day/year);

11.1.1.2 Report author name, company, position, e-mail address and telephone number;

11.1.1.3 Facility name, street address, city, state or province and country;

11.1.1.4 IUT manufacturer, model number, serial number, date calibrated and operator name;

11.1.1.5 Reference Instrument manufacturer, model number, serial number, date calibrated and operator name (repeat if more than one reference instrument is used);

11.1.1.6 The names of other personnel involved in the test;

11.1.1.7 The scan time and mode of operation of the IUT (that is, scanner settings and scan parameters used) when scanning each target;

11.1.1.8 Target properties for both targets to include:

(1) Type of material,

(2) Length, in mm,

(3) Width, in mm,

(4) Reflectance factor, as % of a perfect reflecting diffuser (at the IUT's laser wavelength),

(5) Flatness, in mm.

11.1.1.9 Nominal range to both target plates relative to the IUT, in m;

11.1.1.10 Widths of exclusion regions for each target at the selected ranges, in mm;

11.1.1.11 Expanded Test Uncertainty, in mm;

11.1.1.12 Temperature at the IUT at the beginning and the end of the test, in °C;

11.1.1.13 Temperature at both targets at the beginning and the end of the test, in °C;

11.1.1.14 Whether the test was conducted indoors or outdoors;

11.1.1.15 Manufacturer-specified  $R_{MPE}$ ; and

11.1.1.16 Report author signature and date signed.

11.1.2 The following test results shall be reported:

11.1.2.1 Measured distance between targets, in m for all three repetitions;

11.1.2.2 Reference distance between targets, in m for all three repetitions;

11.1.2.3 Range error,  $e_{range}$ , in mm for all three repetitions;

11.1.2.4 Dispersion of the residuals of the plane fits,  $RMS_1$  and  $RMS_2$  (10.2), in mm for all three repetitions;

11.1.2.5 For each repetition, is the range error in conformance? (Yes/No);

11.1.2.6 IUT in conformance? (Yes/No);

11.1.2.7 Number of measured points that were used for the plane fit for each target for all three repetitions;

11.1.2.8 Plane fitting method used (for example, weighted least-squares); and

11.1.2.9 An image (or screen capture) from the point of view of the IUT of Point Set A1 and Point Set B1 (9.1) for all three repetitions.

### 11.2 Optional Reporting:

11.2.1 The following information may also be reported:

11.2.1.1 Diffuse reflectance factor, as % of a perfect reflecting diffuser (at the IUT's laser wavelength) of each target;

11.2.1.2 Beam widths at the *target 1 range* and *target 2 range*, in mm; and

11.2.1.3 Number of measured points before and after the second data segmentation for each target (see 9.4) for all three repetitions.

## 12. Precision and Bias

12.1 No statement is made concerning either the precision or bias at this time because the developers do not have enough meaningful experience with the test method due to the extreme latitudes allowed in selection of reference instrument(s), target plate characteristics and test setup.

APPENDIXES

(Nonmandatory Information)

X1. AN EXAMPLE IMPLEMENTATION OF THE TEST PROCEDURE

X1.1 Introduction

X1.1.1 An important part of the test method involves alignment of the target plate to the IUT and measurement of the distance between the target plate centers. One way to perform these alignments and measurements is to use a laser tracker or a total station. The laser tracker and total station are similar in that both measure two angles and one distance (range). Both instruments have high angular accuracy, but in general, a laser tracker has better distance (ranging) accuracy.

X1.1.2 This Appendix describes methods to conduct the test using a laser tracker to set up and to align the target plates and to obtain the reference distance. Some adjustment in the procedure may be needed if a total station is used (this topic is not covered in the current version of this document). To determine whether a particular reference instrument (for example, laser tracker or total station) can be used, an uncertainty budget may be constructed. An example is given in Appendix X2.

X1.2 Description and Setup

X1.2.1 There are four steps in the test procedure. The first step is to align and orient the target plates and IUT. The second step is to measure the distance between the centers of the two target plates using the reference instrument. The third step is to scan the two target plates using the IUT (as per Section 8). The fourth step is to calculate the range error (as per 10.1) and RMS dispersion from the collected data (as described in 10.2).

X1.2.2 *Set Up of Laser Tracker and Target Assemblies:*

X1.2.2.1 In an example test setup, a laser tracker is placed on one instrument stand, while a target plate is placed on a second instrument stand. Fig. X1.1 shows an exploded view of a mounted target consisting of a target assembly (20) and a base assembly (50). The target assembly (20) includes a flat target plate (30) that has a front side (31), left side (32), right side (not numbered), top side (33), and bottom side (not numbered), the front side being large enough to make it possible to obtain at least 100 measured points as described in 7.1.2. The target plate (30) might, for example, be a machined

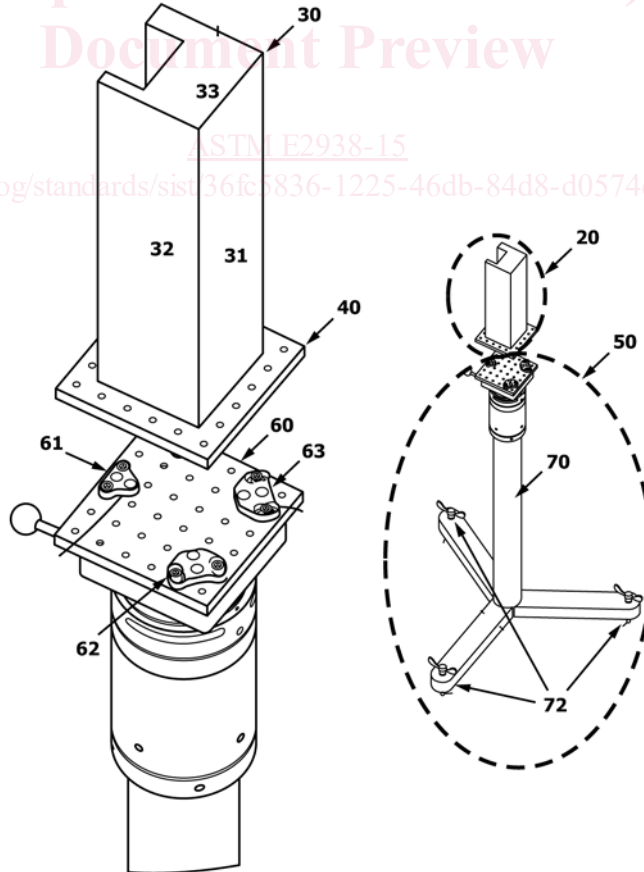

FIG. X1.1 Mounted Target