



Designation: **C473 – 12 C473 – 15**

Standard Test Methods for Physical Testing of Gypsum Panel Products¹

This standard is issued under the fixed designation C473; the number immediately following the designation indicates the year of original adoption or, in the case of revision, the year of last revision. A number in parentheses indicates the year of last reappraisal. A superscript epsilon (ϵ) indicates an editorial change since the last revision or reappraisal.

1. Scope*Scope

- 1.1 These test methods cover the physical testing of gypsum panel products.
- 1.2 The test methods appear in the following order:

	Section
Flexural Strength (Method A)	7
Core, End and Edge Hardness (Method A)	8
Nail Pull Resistance (Method A)	9
Flexural Strength (Method B)	11
Core, End and Edge Hardness (Method B)	12
Nail Pull Resistance (Method B)	13
Humidified Deflection	14
End Squareness	15
Nominal Thickness	16
Recessed- or Tapered Edge Depth	17
Width	18
Length	19
Water Resistance of Core-Treated Water-Repellent Gypsum Panel Products	20
Surface Water Resistance of Gypsum Panel Products with Water-Repellent Surfaces	21

1.3 The values stated in inch-pound units are to be regarded as standard. The values given in parentheses are mathematical conversions to SI units that are provided for information only and are not considered standard.

1.4 The text of these test methods references notes and footnotes that provide explanatory material. These notes and footnotes, excluding those in tables and figures, shall not be considered as requirements of these test methods.

1.5 *This standard does not purport to address all of the safety concerns, if any, associated with its use. It is the responsibility of the user of this standard to establish appropriate safety and health practices and determine the applicability of regulatory limitations prior to use.*

2. Referenced Documents

2.1 *ASTM Standards:*²

[C11 Terminology Relating to Gypsum and Related Building Materials and Systems](#)

[E4 Practices for Force Verification of Testing Machines](#)

[E177 Practice for Use of the Terms Precision and Bias in ASTM Test Methods](#)

[E691 Practice for Conducting an Interlaboratory Study to Determine the Precision of a Test Method](#)

2.2 *Other Standards:*³

[TAPPI T441 Water Absorptiveness of Sized \(Non-Bibulous\) Paper, Paperboard, and Corrugated Fiberboard \(Cobb Test\)](#)

3. Terminology

3.1 Definitions used in these test methods are in accordance with Terminology [C11](#).

3.2 *Definitions of Terms Specific to This Standard:*

¹ These test methods are under the jurisdiction of ASTM Committee [C11](#) on Gypsum and Related Building Materials and Systems and are the direct responsibility of Subcommittee [C11.01](#) on Specifications and Test Methods for Gypsum Products.

Current edition approved ~~Sept. 1, 2012~~ [May 15, 2015](#). Published ~~October 2012~~ [June 2015](#). Originally approved in 1961. Last previous edition approved in ~~2010~~ [2012](#) as [C473C473 – 12, –10](#). DOI: [10.1520/C0473-12.10.1520/C0473-15](#).

² For referenced ASTM standards, visit the ASTM website, [www.astm.org](#), or contact ASTM Customer Service at [service@astm.org](#). For *Annual Book of ASTM Standards* volume information, refer to the standard's Document Summary page on the ASTM website.

³ Available from Technical Association of the Pulp and Paper Industry (TAPPI), 15 Technology Parkway South, Norcross, GA 30092, [http://www.tappi.org](#).

***A Summary of Changes section appears at the end of this standard**

3.2.1 *edge, n*—the paper-bound edge, or long edge, as manufactured.

3.2.2 *ends, n*—the end perpendicular to the paper-bound edge or long edge.

3.2.3 *Test Uncertainty Ratio (TUR), n*—(tolerance of measure) / (precision of the standard measuring instrument)

4. Sampling

4.1 For use in these test methods, a sample shall consist of not less than 0.25 % of the number of gypsum panel products in a shipment, but not less than three gypsum panel products. Test specimens shall be taken from the sample lot as indicated in each method.

5. Conditioning

5.1 Condition specimens to constant weight at a temperature of $85 \pm 15^{\circ}\text{F}$ ($29.5 \pm 8.5^{\circ}\text{C}$) and relative humidity of $50 \pm 2\%$ (Note 1). Test specimens individually after constant weight is reached and within 10 min upon removal from the conditioning chamber.

NOTE 1—Laboratory test results indicated that conditioning temperatures may range from 70 to 100°F (21 to 38°C) without significantly affecting the results. However, relative humidity is critical. This is the reason for testing specimens within 10 min upon removal from the conditioning chamber.

Method A—Constant Rate of Loading

INTRODUCTION

The following procedures are applicable to so-called “shot machines” that utilize lead or steel shot that applies a load to the specimen at a constant stress rate or any other device that applies the load at a constant stress rate.

6. Apparatus—Method A

6.1 *Testing Machine*—Apply the test load at a uniform rate of 1 lbf/s (4.45 N/s) $\pm 10\%$. Apply the load with a device independent of manual control of the rate of loading during an individual sample test (see Fig. 1). The deformation of the specimen controls the cross head speed.

7. Flexural Strength (Method A)

7.1 *Summary of Test Method*—Flexural properties of gypsum panel products are evaluated by supporting the specimen near the ends and applying a transverse load midway between the supports.

7.2 *Significance and Use*—This test method covers a procedure for evaluating the ability of gypsum panel products to withstand flexural stresses during handling or use of the material. This test method is used to determine compliance with gypsum panel product specifications. The degree of correlation between this test and service performance has not been fully determined.

7.3 *Apparatus*—See Section 6.1.

7.3.1 *Specimen Supports*—All specimen bearing supports and load surfaces shall be true, shall engage the full width of the test specimen, shall be of such strength they will not deform under the test load, and shall be rounded to a radius of 0.125 in. (3.2 mm). The specimen supports shall be spaced 14 ± 0.016 in. (356 ± 0.41 mm) on centers measured at the points of surface contact with the specimen. The supports shall be attached to a plate that shall be rigidly attached to the test apparatus. The supports shall be parallel to each other and perpendicular to the long dimension of the test specimen. The bearing surface of the end supports shall be on the same plane to ensure contact along the entire bearing surfaces. Supports shall be not less than 12 in. (305 mm) in length. When a load is being applied, the loading bar shall be in contact with the full width of the specimen. The load-bearing surface shall be parallel to the bearing surface of the specimen supports. The specimen and supports shall be located so that the vertical axis through the center of the load-bearing surface passes through the specimen at one half of the specimen width and one half of the distance between the supports.

7.4 *Sampling*—Sampling shall be in accordance with Section 4.

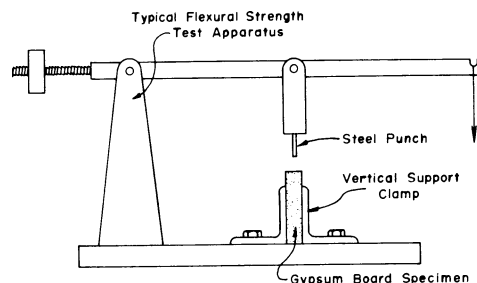

FIG. 1 Apparatus Schematic for Core, End, and Edge Hardness Test

7.5 Test Specimens:

7.5.1 Cut four specimens, each 12 in. (305 mm) by approximately 16 in. (406 mm) from each gypsum panel product in the sample, two having the 16-in. dimension parallel to the edge and two having the 16-in. dimension perpendicular to the edge. Cut the specimens not less than 4 in. (102 mm) away from the ends and edges of the gypsum panel product except where the product is 24-in. or less in width, where it is impossible to do so.

7.5.2 Condition specimens in accordance with Section 5.

7.6 Procedure:

7.6.1 Use the apparatus in 7.3, supporting each specimen centrally on the fixed parallel bearings, 14-in. (356 mm) on centers, and apply the load on a similar bearing midway between the supports. Position perforated gypsum lath so the load is not applied over perforations.

7.6.2 For specimens with the long dimension parallel to the edge, test one specimen from each gypsum panel product face up and the other face down. For specimens with the long dimension perpendicular to the edge, test one specimen from each gypsum panel product face up and the other face down.

7.6.3 For gypsum panel products with surfacing material, the load is determined at the time of transverse failure of the surfacing material and core through the thickness of the specimen. The specimens shall not show a break in the bond between the surfacing and the core before transverse failure of the gypsum panel product. If a single specimen fails, test two additional specimens from the same sample, and, if either one of the two specimen fail, the sample has failed. For gypsum panel products without surfacing material, the load is determined at the time of transverse failure through the thickness of the specimen.

7.7 *Report*—Calculate and report the average breaking load in pound-force or newtons for each test condition, rounded to the nearest 1 lbf (N). The test conditions are: (1) parallel, face up; (2) parallel, face down; (3) perpendicular, face up; and, (4) perpendicular, face down.

7.8 *Precision and Bias*—See Section 22 and Tables 1 and 2.

8. Core, End, and Edge Hardness (Method A)

8.1 *Summary of Test Method*—The core, end, and edge hardness of gypsum panel products is evaluated by determining the force required to push a steel punch into the area of test.

8.2 *Significance and Use*—This test method covers a procedure for evaluating the ability of the gypsum panel product core, ends, and edges to resist crushing during handling or use of the material. This test method is used to determine compliance with gypsum panel product specifications. The degree of correlation between these test methods and service performance has not been determined.

8.3 *Apparatus*—See 6.1. Clamp or secure the specimen to the base of the test apparatus shown in Fig. 1 with the face of the specimen perpendicular to the base of the test apparatus and parallel to the movement of the steel punch. Secure the steel punch to the moving head of the test apparatus, positioned so that its center axis is parallel with the line of travel and so that the punch is inserted into the core equidistant from the surfaces of the specimen. Use a steel punch 0.099 ± 0.003 in. (2.515 ± 0.076 mm) in diameter and more than 1/2 in. (12.7 mm) long with the bearing surface machined to a 90° angle in reference to the punch center line (see Fig. 1 for test setup schematic).

8.4 *Sampling*—Sampling shall be in accordance with Section 4.

8.5 Test Specimens:

8.5.1 *Specimens for Core Hardness*—Using a table or band saw, cut one specimen from the center of each gypsum panel product sample approximately 12 by not less than 3 in. (305 by 76 mm), with the 12-in. dimension perpendicular to the edges of the products. The smaller, not less than 3 in., dimension will vary depending on the specific punch length and opening in the testing machines. Place the sample in the tester, with the loading arm in a horizontal position and with the punch resting on the specimen. Saw cuts along the 12-in. dimension shall be smooth and square with the smaller (not less than 3-in.) dimension, as well as with the specimen.

TABLE 1 Parallel Flexural Strength, Method B (lbf) 5 Labs / 81 Data Points

Panel	Average ^A	Standard Deviation of the Sample Averages	Repeatability Standard Deviation	Reproducibility Standard Deviation	Repeatability Limit	Reproducibility Limit
	\bar{x}	$s_{\bar{x}}$	s_r	s_R	r	R
A	49.4871	6.3911	11.9766	12.6641	33.5344	35.4593
B	85.2847	5.4871	16.3279	16.3279	45.7180	45.7180
C	35.6045	4.3757	6.3969	7.2970	17.9112	20.4316

^A The average of the laboratories' calculated averages.

TABLE 2 Perpendicular Flexural Strength, Method B (lbf) 7 Labs / 117 Data Points

Panel	Average ^A	Standard Deviation of the Sample Averages	Repeatability Standard Deviation	Reproducibility Standard Deviation	Repeatability Limit	Reproducibility Limit
	\bar{x}	$s_{\bar{x}}$	s_r	s_R	r	R
A	138.1732	3.8219	6.2402	6.8598	17.4725	19.2075
B	206.7995	7.4186	8.8020	10.9361	24.6457	30.6212
C	80.0015	1.9580	1.5868	2.4356	4.4431	6.8196

^AThe average of the laboratories' calculated averages.

8.5.2 *Specimens for End Hardness*—Cut specimens the same size and method as described in 8.5.1 from one mill-cut end of the gypsum panel product, with the 12-in. ~~(305-mm)~~ (305 mm) dimension perpendicular to the edges and run tests only on the mill-cut end of the specimens.

8.5.3 *Specimens for Edge Hardness*—Cut specimens the same size and method as described in 8.5.1 from the opposite edges of each gypsum panel product, with the 12 in. (305 mm) dimension of the specimens parallel with the edges. For gypsum panel products with surfacing material, cut a ¼ to ½-in. (6 to ~~13-mm~~) 13 mm) strip of surfacing material from the edge of the test specimens exposing the core for test. Remove as little of the core as possible when removing the surfacing material. Prepare the first test area 2 ± ½ in. (51 ± 13 mm) from one edge of the specimen, with the next two test areas approximately ~~4 in.~~ 4 in. (102 mm) apart.

8.5.4 Condition specimens in accordance with Section 5.

8.6 *Procedure*—Using the apparatus in 8.3, clamp or secure the specimen in a fixed vertical position on its 12 in. (305 mm) dimension edge (see Fig. 1 for test setup schematic. If necessary, modify the flexural strength test equipment to conduct the core, end, and edge hardness test). Place this test surface not less than 1 in. (25 mm) above the grip of the specimen holder. Conduct three tests spaced approximately ~~4 in.~~ 4 in. (102 mm) apart on each specimen, with the first test area 2 ± ½ in. (51 ± 13 mm) from one edge of the specimen. Position the steel punch over the test area and apply the load. Report as the core, end, or edge hardness the load required to push the steel punch a distance of ½ in. (13 mm) into the core of the specimen.

8.6.1 *Procedure for Core Hardness*—Test in ~~3~~ three locations on either of the 12-in. ~~(305-mm)~~ (305 mm) saw cut edges of each specimen.

8.6.2 *Procedure for End Hardness*—Test in ~~3~~ three locations on the 12-in. ~~(305-mm)~~ (305 mm) mill-cut end of each specimen.

8.6.3 *Procedure for Edge Hardness*—Test in ~~3~~ three locations along each of the two 12-in. ~~(305-mm)~~ (305 mm) edges. For products with surfacing material, test where the surfacing material has been removed.

8.7 *Report*—Report the core, end, and edge hardness individually as the average load in pounds-force or newtons rounded to the nearest 1 lbf (N). Discard any single test value that varies from the average by more than 15 % and repeat the test on the same sample to obtain a new value.

8.8 *Precision and Bias*—See Section 22 and Tables 3-5.

9. Nail Pull Resistance (Method A)

9.1 *Summary of Test Method*—The ability of gypsum panel products to resist nail pull-through is evaluated by determining the load required to push a standard nail head through the product.

9.2 *Significance and Use*—This test method covers a procedure for evaluating the ability of gypsum panel products to resist nail pull-through by determining the load required to force a standard nail head through the product. This test method is used to determine compliance with gypsum panel product specifications. The degree of correlation between these test methods and service performance has not been determined.

9.3 *Apparatus*—See 6.1. This apparatus shall be used with either of the specimen support plates in 9.3.1 or 9.3.2.

TABLE 3 Core Hardness, Method B (lbf) 10 Labs / 71 Data Points

Panel	Average ^A	Standard Deviation of the Sample Averages	Repeatability Standard Deviation	Reproducibility Standard Deviation	Repeatability Limit	Reproducibility Limit
	\bar{x}	$s_{\bar{x}}$	s_r	s_R	r	R
A	22.4517	3.6610	1.0726	3.7896	3.0032	10.6110
B	24.4100	1.4329	1.2323	1.8218	3.4505	5.1010
C	25.4926	N/A	0.6774	0.6774	1.8968	1.8968

^AThe average of the laboratories' calculated averages.

TABLE 4 End Hardness, Method B (lbf) 10 Labs / 60 Data Points

Panel	Average ^A	Standard Deviation of the Sample Averages	Repeatability Standard Deviation	Reproducibility Standard Deviation	Repeatability Limit	Reproducibility Limit
	$\bar{\bar{x}}$	$s_{\bar{y}}$	s_r	s_R	r	R
A	27.2263	N/A	0.6353	0.6353	1.7790	1.7790
B	24.5387	1.8854	1.0977	2.1351	3.0737	5.9784

^AThe average of the laboratories' calculated averages.

TABLE 5 Edge Hardness, Method B (lbf) 10 Labs / 120 Data Points

Panel	Average ^A	Standard Deviation of the Sample Averages	Repeatability Standard Deviation	Reproducibility Standard Deviation	Repeatability Limit	Reproducibility Limit
	$\bar{\bar{x}}$	$s_{\bar{y}}$	s_r	s_R	r	R
A	60.3630	N/A	9.3561	9.3561	26.1970	26.1970
B	60.7652	5.5456	7.6803	9.2100	21.5047	25.7880

^AThe average of the laboratories' calculated averages.

9.3.1 Fig. 2 shows a schematic of a nail pull resistance apparatus adaptable to a typical flexural strength apparatus commonly used in the gypsum industry. The specimen support plate shall have a 3-in. (76-mm) (76 mm) diameter hole in the center. The support plate shall be not less than 6 by 6 in. (152 by 152 mm) (152 mm). It shall be attached to the apparatus as necessary to maintain the surface of the plate perpendicular to the travel of the test nail. The support plate must also be located so that the vertical axis through the center of the nail shank passes through the center of the hole in the support plate. The test nail shank shall be 0.099 ± 0.003 in. (2.515 ± 0.076 mm) in diameter and the nail head shall be 0.250 ± 0.005 in. (6.350 ± 0.127 mm) in diameter. The nail shall be attached at the head to the movable cross head of the test apparatus. This attachment shall not exceed the diameter of the nail head and shall be placed directly over the head. It shall also be attached so that the vertical axis through the nail shank is parallel with the travel.

9.3.2 Fig. 3 shows a schematic of an alternate nail pull resistance apparatus adaptable to a typical flexural strength apparatus commonly used in the gypsum industry. This apparatus mirrors all of the requirements of 9.3.1, except that the nail is not attached at the head to the movable cross head of the test apparatus. The alternate apparatus utilizes a machined plunger with the nail head and shank incorporated as an integral part of the plunger. The plunger fits into a bushing that keeps the nail aligned perpendicular to the test specimen. Manufacture the plunger to slide freely through the bushing without the application of any load.

NOTE 2—Other devices or means of allowing the plunger to move freely (such as collar bearings, etc.) and so forth are also acceptable.

9.4 Sampling—Sampling shall be in accordance with Section 4.

9.5 Test Specimens:

9.5.1 Cut five specimens 6 by 6 in. (152 by 152 mm) from a strip cut across the width of each 48-in. (1220-mm) (1220 mm) gypsum panel product starting not less than 4 in. (102 mm) in from the edge. Cut a total of five specimens from more than one full width strip from gypsum panel products less than 38 in. (965-mm) (965 mm) wide. Do not cut the specimen closer than 3 in. (76-mm) (76 mm) from the product edges.

9.5.2 Drill a 1/64-in. (2.778-mm) (2.778 mm) diameter pilot hole through the thickness of the gypsum panel product in the center of each test specimen and perpendicular to the surface.

9.5.3 Condition specimens in accordance with Section 5.

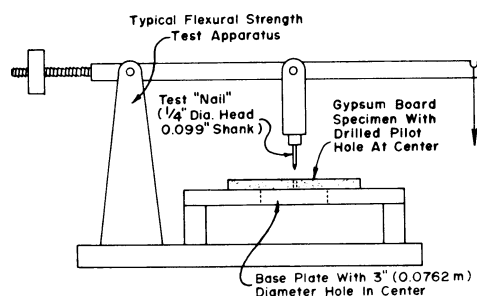
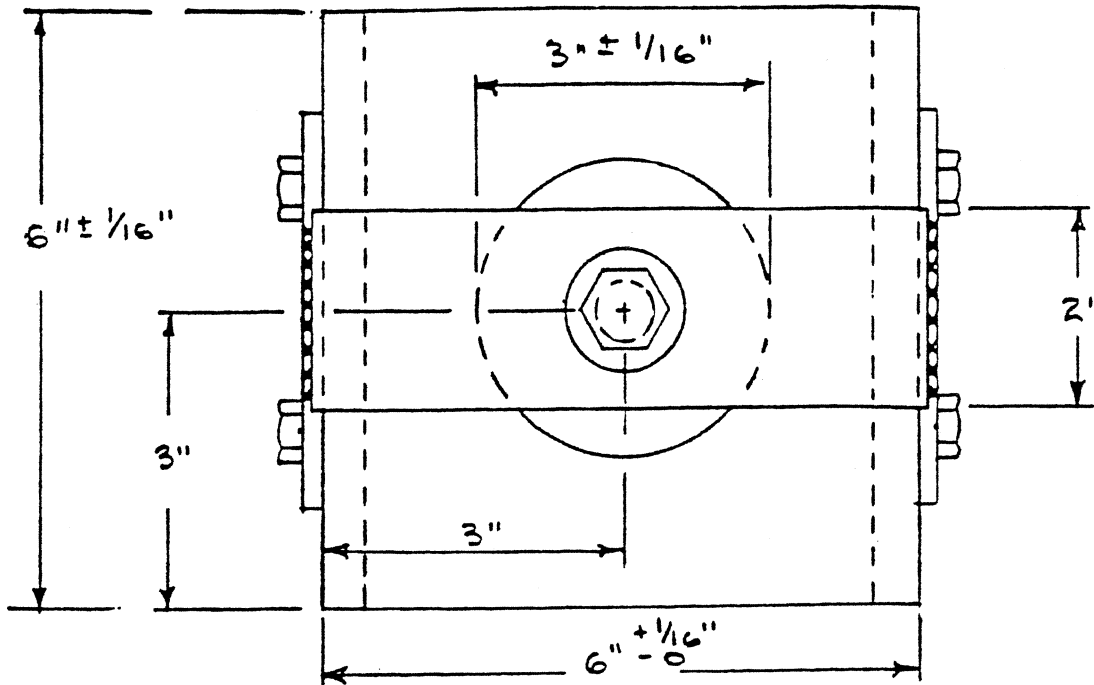

FIG. 2 Apparatus Schematic for Nail-Pull Resistance Test

TOP VIEW



LOAD FROM BAR ATTACHED TO TRANSVERSE TESTER ARM

BRONZE OR BRASS BUSHING
PRESS FIT WITH .001"
CLEARANCE FOR PLUNGER

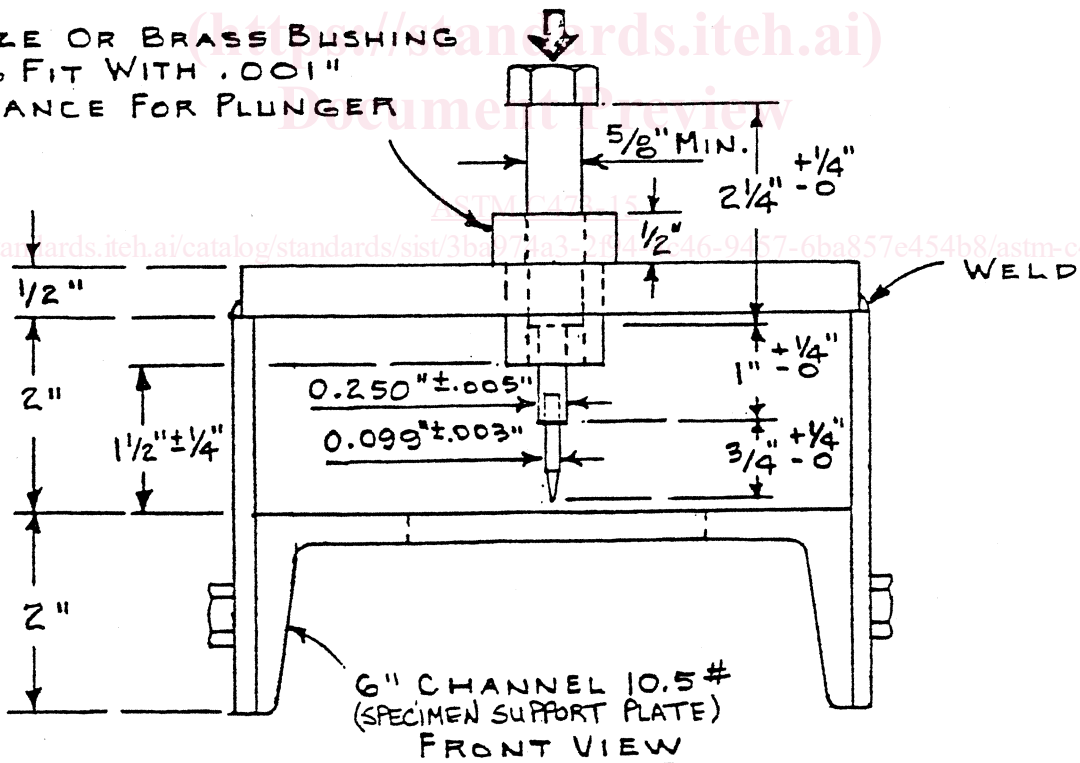

FIG. 3 Typical Nail Pull Specimen Support Plate

9.6 *Procedure*—Using the apparatus in 9.3, center the specimen face up on the base plate and manually lower the test nail, inserting the nail shank in the pilot hole, until the nail head is flush with the surface of the specimen. Apply the load until the maximum load is achieved. Normally, this will occur as the nail head breaks through the gypsum panel product surface.

9.7 *Report*—Calculate the average maximum load in pounds-force or newtons, rounded to the nearest 1 lbf (N). Discard any single test that varies from the average by more than 15 %. If more than 15 % of the test values are discarded, repeat the test.

9.8 *Precision and Bias*—See Section 22 and Table 6.

Method B—Constant Rate of Cross Head Speed

INTRODUCTION

The following procedures are applicable to so-called universal test machines. These instruments often use electronic load cells and data acquisition equipment to gather information about the specimen being tested. The instruments generally in use move the cross head at a constant speed, as opposed to having the deformation on the specimen control cross head speed, which would be a true constant rate of strain instrument.

10. Apparatus

10.1 *Testing Machine*, of any type that is of sufficient capacity and that is capable of providing a rate of loading at a strain rate of 1.0 in./min ± 5 s (25 mm/min ± 5 s). The load platform of the test equipment shall be of sufficient size to accept the specimen holder and load applying apparatus. The testing machine shall be power operated and shall apply the load continuously and without shock.

10.2 The test apparatus shall be verified according to Practices E4, the three sections titled “Basis of Verification,” “Corrections,” and “Time Interval Between Verifications.”

10.3 *Load-Indicating Equipment*, capable of reading to 1-lbf (4.45-N) increments, shall be provided for the test apparatus. A means shall be provided to indicate the maximum load attained during the test.

11. Flexural Strength (Method B)

11.1 *Summary of Test Method*—Flexural properties of gypsum panel products are evaluated by supporting the specimen near the ends and applying a transverse load midway between the supports.

11.2 *Significance and Use*—This test method covers a procedure for evaluating the ability of gypsum panel products to withstand flexural stresses during handling or use of the material. This test method is used to determine compliance with gypsum panel product specifications. The degree of correlation between this test and service performance has not been fully determined.

11.3 *Apparatus*—See Section 10.

11.3.1 *Specimen Supports*—All bearing supports and load surfaces shall be true, shall engage the full width of the test specimen, shall be of such strength they will not deform under the test load, and shall be rounded to a radius of 0.125 in. (3.2 mm). The specimen supports shall be spaced 14 ± 0.016 in. (356 ± 0.41 mm) on centers measured at the points of surface contact with the specimen. The supports shall be attached to a plate that shall be rigidly attached to the test apparatus. Test specimen supports shall be parallel to each other and perpendicular to the long dimension of the test specimen. The bearing surface of the end supports shall be on the same plane to ensure contact along the entire bearing surfaces. Supports shall be not less than 12 in. (305 mm) in length. When a load is being applied, the loading bar shall be in contact with the full width of the specimen. The load-bearing surface shall be parallel to the bearing surface of the specimen supports. The specimen and specimen supports shall be located so that the vertical axis through the center of the load-bearing surface passes through the specimen at one half of the specimen width and one half of the distance between the supports (see Fig. 4).

11.4 *Sampling*—Sampling shall be in accordance with Section 4.

11.5 *Test Specimen*:

TABLE 6 Nail Pull Resistance, Method B (lbf) 10 Labs / 180 Data Points

Panel	Average ^A	Standard Deviation of the Sample Averages	Repeatability Standard Deviation	Reproducibility Standard Deviation	Repeatability Limit	Reproducibility Limit
	\bar{x}	$s_{\bar{x}}$	s_r	s_R	r	R
A	76.7023	3.9561	2.8870	4.7536	8.0837	13.3100
B	87.5646	4.1139	2.6243	4.7606	7.3479	13.3296
C	59.3105	5.1849	2.6658	5.7275	7.4642	16.0371

^A The average of the laboratories' calculated averages.

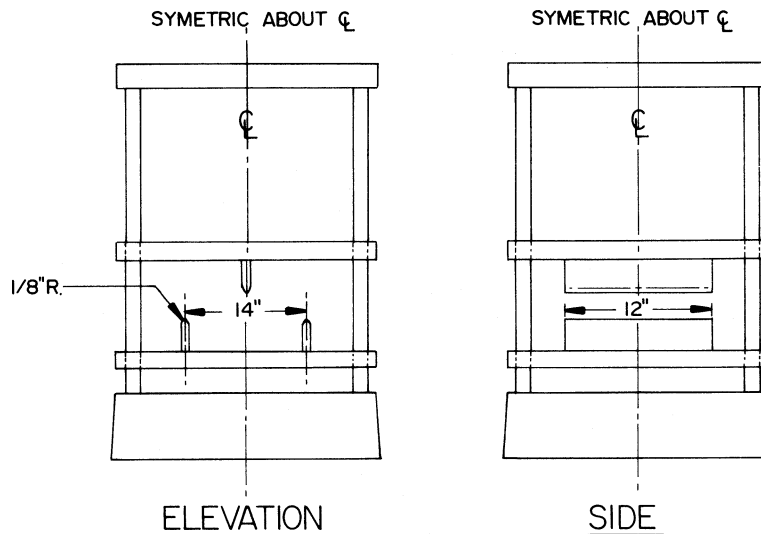

FIG. 4 Testing Machine

11.5.1 Cut four specimens, each 12 in. (305 mm) by approximately 16 in. (406 mm) from each gypsum panel product in the sample, two having the 16-in. dimension parallel to the edge and two having the 16-in. dimension perpendicular to the edge. Cut the specimens not less than 4 in. (102 mm) away from the ends and edges of the gypsum panel product except where the product is 24-in. or less in width, where it is impossible to do so.

11.5.2 Condition specimens in accordance with Section 5.

11.6 Procedure:

11.6.1 Use the apparatus in 11.3, supporting each specimen centrally on the fixed parallel supports, 14-in. (356 mm) on centers, and apply the load on a similar bearing midway between the supports. Position perforated gypsum lath so the load is not applied over perforations.

11.6.2 For specimens with the long dimension parallel to the edge, test one specimen from each gypsum panel product face up and the other face down. For specimens with the long dimension perpendicular to the edge, test one specimen from each gypsum panel product face up and the other face down.

11.6.3 For gypsum panel products with surfacing material, the load is determined at the time of transverse failure of the surfacing material and core through the thickness of the specimen. The specimens shall not show a break in the bond between the surfacing and the core before transverse failure of the gypsum panel product. If a single specimen fails, test two additional specimens from the same sample, and, if either one of the two specimens fail, the sample has failed. For gypsum panel products without surfacing material, the load is determined at the time of transverse failure through the thickness of the specimen.

11.7 Report—Calculate and report the average breaking load in pounds-force or newtons for each test condition, rounded to the nearest 1 lbf (N). The test conditions are: (1) parallel, face up; (2) parallel, face down; (3) perpendicular, face up; and, (4) perpendicular, face down.

11.8 Precision and Bias:

11.8.1 Precision—The 95 % repeatability limit of the Parallel, Face Up (Method B) test is the test result ± 4.796 lbf [21.33 N]. The 95 % reproducibility limit of the Parallel, Face Up (Method B) test is the test result ± 8.992 lbf [40.00 N].

11.8.2 Precision—The 95 % repeatability limit of the Parallel, Face Down (Method B) test is the test result ± 5.087 lbf ± 5.087 lbf [22.63 N]. The 95 % reproducibility limit of the Parallel, Face Down (Method B) test is the test result ± 7.370 lbf [32.78 N].

11.8.3 Precision—The 95 % repeatability limit of the Across, Face Up (Method B) test is the test result ± 10.290 lbf [45.77 N]. The 95 % reproducibility limit of the Across, Face Up (Method B) test is the test result ± 13.368 lbf [59.46 N].

11.8.4 Precision—The 95 % repeatability limit of the Across, Face Down (Method B) test is the test result ± 11.704 lbf ± 11.704 lbf [52.06 N]. The 95 % reproducibility limit of the Across, Face Down (Method B) test is the test result ± 19.429 lbf ± 19.429 lbf [86.42 N].

11.8.5 Bias—No information can be presented on the bias of the procedure in these test methods for measuring the Flexural Strength (Method B) because there is no material having an accepted reference value.

12. Core, End, and Edge Hardness (Method B)

12.1 Summary of Test Method—The core, end, and edge hardness of gypsum panel products is evaluated by determining the force required to push a steel punch into the area of test.

12.2 *Significance and Use*—This test method covers a procedure for evaluating the ability of the gypsum panel product core, ends, and edges to resist crushing during handling or use of the material. This test method is used to determine compliance with gypsum panel product specifications. The degree of correlation between this test method and service performance has not been fully determined.

12.3 *Apparatus*—See Section 10.

12.3.1 A means of securing the specimen to the base of the test apparatus shall be provided. The face of the specimen shall be perpendicular to the base of the test apparatus and parallel to the movement of the steel punch. The steel punch shall be secured to the moving head of the test apparatus. It shall be positioned so that its center axis is parallel with the line of travel. It also shall be positioned so that the punch is inserted into the core equidistant from the surfaces of the specimen. The steel punch shall be 0.099 ± 0.003 in. (2.515 ± 0.076 mm) in diameter and more than $\frac{1}{2}$ in. (12.7 mm) long with the bearing surface machined to a 90° angle in reference to the punch center line (see Fig. 5 and Fig. 6).

12.4 *Sampling*—Sampling shall be in accordance with Section 4.

12.5 *Test Specimens:*

12.5.1 *Specimens for Core Hardness*—Using a table or band saw, cut a specimen not less than 12 by 3 in. (305 by 76 mm) from the center of each gypsum panel product. The 12-in. (~~305-mm~~)(305 mm) dimension shall be perpendicular to the edges of the gypsum panel product. Cuts along the 12 in. (~~305-mm~~)(305 mm) dimension shall be smooth and perpendicular to the face of the specimen.

12.5.2 *Specimens for End Hardness*—Cut a specimen not less than 12 by 3 in. (305 by 76 mm) from one mill-cut end of each gypsum panel product. Cut the 12-in. (~~305-mm~~)(305 mm) dimension perpendicular to the edges of the gypsum panel product.

12.5.3 *Specimens for Edge Hardness*—Cut a specimen not less than 12 by 3 in. (305 by 76 mm) from each edge of each gypsum panel product. Cut the 12-in. (~~305-mm~~)(305 mm) dimension parallel to the edge of the gypsum panel product. For gypsum panel products with surfacing material, cut a $\frac{1}{4}$ to $\frac{1}{2}$ -in. (6 to ~~13-mm~~)(13 mm) strip of surfacing material from the edge of the test specimens exposing the core for test. Remove as little of the core as possible when removing the surfacing material. Prepare the first test area $2 \pm \frac{1}{2}$ in. (51 ± 13 mm) from one edge of the specimen, with the next two test areas spaced approximately 4 in. (102 mm) apart.

12.5.4 Condition specimens in accordance with Section 5.

12.6 *Procedure*—Using the apparatus in 12.3, clamp or secure the specimen in a fixed vertical position on its 12 in. (305 mm) dimension edge. If necessary, modify the flexural strength test equipment to conduct the core, end, and edge hardness test. Place this test surface not less than 1 in. (25 mm) above the grip of the specimen holder. After the specimen is in place, zero the load indicator. Conduct three tests spaced approximately 4 in. (102 mm) apart on each specimen, with the first test area $2 \pm \frac{1}{2}$ in. (51 ± 13 mm) from one edge of the specimen. Position the steel punch over the test area and apply the load. Report as the core, end, or edge hardness the load required to push the steel punch a distance of $\frac{1}{2}$ in. (13 mm) into the core of the specimen.

12.6.1 *Procedure for Core Hardness*—Test in ~~three~~ three locations on either of the 12-in. (~~305-mm~~)(305 mm) saw cut edges of each specimen.

12.6.2 *Procedure for End Hardness*—Test in ~~three~~ three locations on the 12-in. (~~305-mm~~)(305 mm) mill-cut end of each specimen.

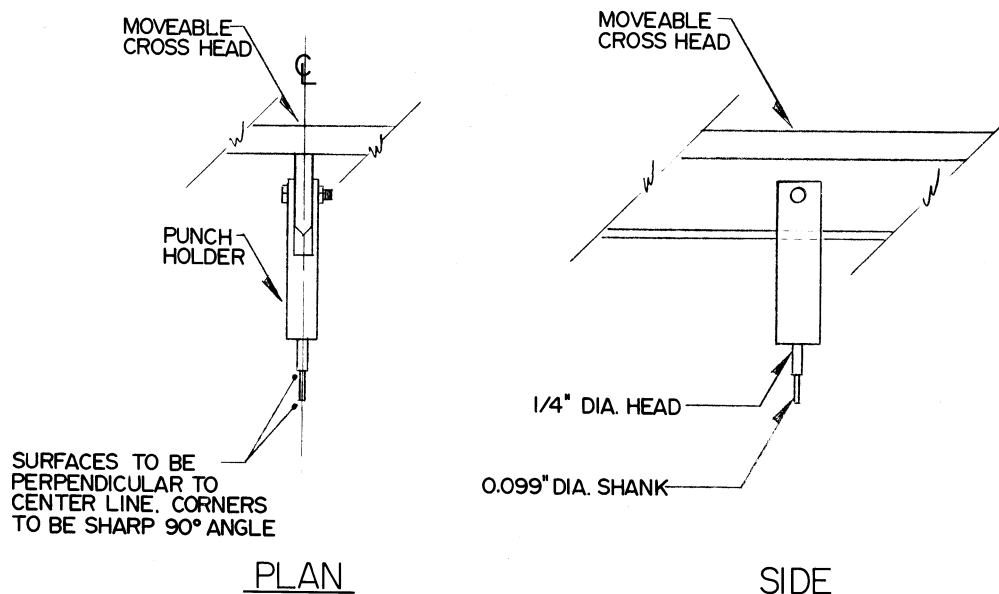

FIG. 5 Test Setup—Punch for Hardness and Nail Pull Resistance

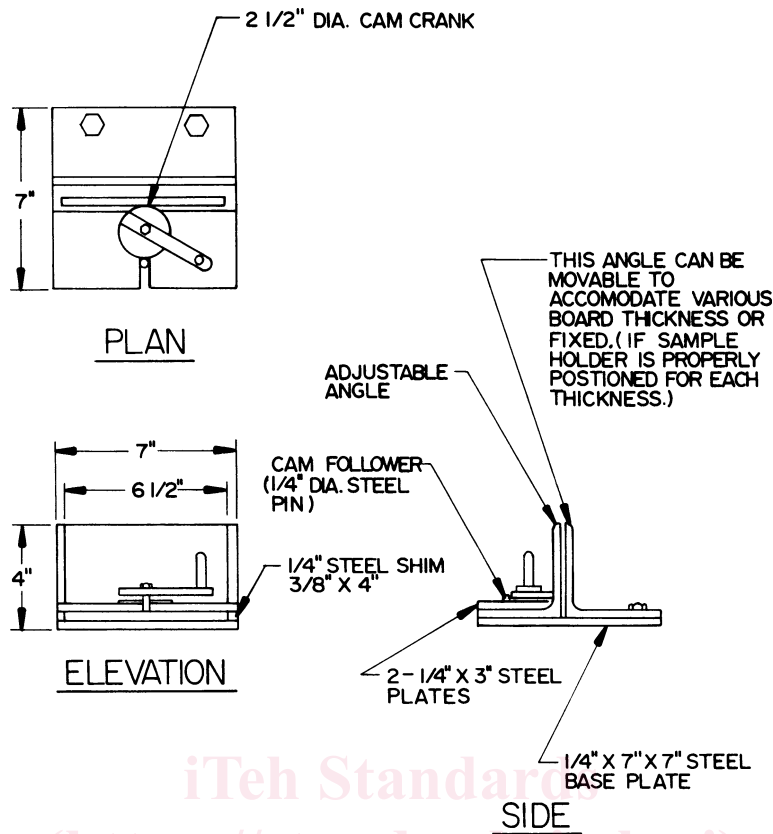

FIG. 6 Test Setup—Sample Holder for Hardness Test

12.6.3 *Procedure for Edge Hardness*—Test in three locations along each of the two 12-in. (305-mm) (305 mm) edges. For products with surfacing material, test where the surfacing material has been removed.

12.7 *Report*—Report the core, end, and edge hardness individually as the average load in pounds-force or newtons rounded to the nearest 1 lbf (N). Discard any single test value that varies from the average by more than 15 % and repeat the test on the same sample to obtain a new value.

12.8 *Precision and Bias:*

12.8.1 *Precision*—The 95 % repeatability limit of the End Hardness (Method B) test is the test result ± 8.103 lbf [36.04 N]. The 95 % reproducibility limit of the End Hardness (Method B) test is the test result ± 9.725 lbf [43.56 N].

12.8.2 *Precision*—The 95 % repeatability limit of the Core Hardness (Method B) test is the test result ± 4.231 lbf [18.82 N]. The 95 % reproducibility limit of the Core Hardness (Method B) test is the test result ± 9.668 lbf [43.01 N].

12.8.3 *Precision*—The 95 % repeatability limit of the Edge Hardness (Method B) test is the test result ± 7.730 lbf [34.38 N]. The 95 % reproducibility limit of the Edge Hardness (Method B) test is the test result ± 23.031 lbf [102.45 N].

12.8.4 *Bias*—No information can be presented on the bias of the procedure in these test methods for measuring the End, Core, and Edge Hardness because there is no material having an accepted reference value.

13. **Nail Pull Resistance (Method B)**

13.1 *Summary of Test Method*—The ability of gypsum panel products to resist nail pull-through is evaluated by determining the load required to push a standard nail head through the product.

13.2 *Significance and Use*—This test method covers a procedure for evaluating the ability of gypsum panel products to resist nail pull-through by determining the load required to force a standard nail head through the product. This test method is used to determine compliance with gypsum panel product specifications. The degree of correlation between these test methods and service performance has not been determined.

13.3 *Apparatus*—See Section 10. The apparatus shall be used with either of the specimen support plates in 13.3.1 or 13.3.2.

13.3.1 *Specimen Support Plate*, shall be true and have a 3-in. (76-mm) (76 mm) diameter hole in the center. The support plate shall be not less than 6 by 6 in. (152 by 152 mm). It shall be attached to the apparatus as necessary to maintain the surface of the plate perpendicular to the travel of the test nail. The support plate must also be located so that the vertical axis through the center of the nail shank passes through the center of the hole in the support plate. The test nail shank shall be 0.099 ± 0.003 in. (2.515