



Designation: D3641 – 15

Standard Practice for Injection Molding Test Specimens of Thermoplastic Molding and Extrusion Materials¹

This standard is issued under the fixed designation D3641; the number immediately following the designation indicates the year of original adoption or, in the case of revision, the year of last revision. A number in parentheses indicates the year of last reapproval. A superscript epsilon (ϵ) indicates an editorial change since the last revision or reapproval.

1. Scope*

1.1 This practice covers the general principles to be followed when injection molding test specimens of thermoplastic molding and extrusion materials. This practice is to be used to obtain uniformity in methods of describing the various steps of the injection molding process and to set up uniform methods of reporting these conditions. The exact conditions required to prepare suitable specimens will vary for each plastic material. Any requirements or recommendations in the material specification that differ from this standard take precedence over those in this standard. Always consult the referenced material document for specimen preparation. If no referenced document exists, then consult the material supplier for specimen preparation guidance and note such in the test report.

1.2 The methodology presented assumes the use of reciprocating screw injection molding machines.

1.3 The values stated in SI units are to be regarded as the standard. The values given in parentheses are for information only.

1.4 *This standard does not purport to address all of the safety concerns, if any, associated with its use. It is the responsibility of the user of this standard to establish appropriate safety and health practices and determine the applicability of regulatory limitations prior to use.*

NOTE 1—This practice is equivalent to the following parts of ISO 294: Plastics—Injection Moulding of Test Specimens of Thermoplastic Materials; 294-1: Part 1—General Principles and Multipurpose Test Specimens (ISO Type A Mould) and Bars (ISO Type B Mould); ISO 294-2: Part 2—Small Tensile Bars (ISO Type C Mould); ISO 294-3: Part 3—Plates (ISO Type D Moulds).

2. Referenced Documents

2.1 ASTM Standards:²

¹ This practice is under the jurisdiction of ASTM Committee D20 on Plastics and is the direct responsibility of Subcommittee D20.09 on Specimen Preparation.

Current edition approved May 1, 2015. Published June 2015. Originally approved 1991. Last previous edition approved 2014 as D3641 – 14. DOI: 10.1520/D3641-15.

² For referenced ASTM standards, visit the ASTM website, www.astm.org, or contact ASTM Customer Service at service@astm.org. For *Annual Book of ASTM Standards* volume information, refer to the standard's Document Summary page on the ASTM website.

D256 Test Methods for Determining the Izod Pendulum Impact Resistance of Plastics

D570 Test Method for Water Absorption of Plastics

D638 Test Method for Tensile Properties of Plastics

D648 Test Method for Deflection Temperature of Plastics Under Flexural Load in the Edgewise Position

D790 Test Methods for Flexural Properties of Unreinforced and Reinforced Plastics and Electrical Insulating Materials

D883 Terminology Relating to Plastics

D955 Test Method of Measuring Shrinkage from Mold Dimensions of Thermoplastics

D957 Practice for Determining Surface Temperature of Molds for Plastics

D1525 Test Method for Vicat Softening Temperature of Plastics

D6110 Test Method for Determining the Charpy Impact Resistance of Notched Specimens of Plastics

2.2 ISO Standards:³

ISO 294-1: Plastics—Injection Moulding of Test Specimens of Thermoplastic Materials—Part 1: General Principles and Multipurpose Test Specimens (ISO Type A Mould) and Bars (ISO Type B Mould)

ISO 294-2: Plastics—Injection Moulding of Test Specimens of Thermoplastic Materials—Part 2: Small Tensile Bars (ISO Type C Mould)

ISO 294-3: Plastics—Injection Moulding of Test Specimens of Thermoplastic Materials—Part 3: Plates (ISO Type D Moulds)

ISO 20753 Plastics—Test Specimens

3. Terminology

3.1 *Definitions*—Definitions of terms applying to this practice appear in Terminology D883.

3.2 *Definitions of Terms Specific to This Standard:*

3.2.1 *average injection velocity, n*—the mean value of the velocity of the molten plastic flow front within a cavity during the injection time that is calculated from the shot volume and injection time. (See Terminology D883.)

³ Available from American National Standards Institute (ANSI), 25 W. 43rd St., 4th Floor, New York, NY 10036, http://www.ansi.org.

*A Summary of Changes section appears at the end of this standard

3.2.1.1 *Discussion*—The average injection velocity is calculated as follows:

$$V_{av} = \frac{V_s}{T_i \times A_c \times n}$$

where:

- V_{av} = average injection velocity, mm/s,
- V_s = shot volume, mm³,
- T_i = injection time, s,
- A_c = cross section of the cavity, mm², (see 3.2.2) and
- n = number of cavities.

The calculation is valid for molds containing a single cavity or those containing identical multi-specimen cavities only. This calculation does not apply for family molds.

3.2.2 *cross section of the cavity, n*—in a mold for test specimens, the area of a planar section perpendicular to the flow pattern during filling of the mold that forms the critical portion of the test specimen.

3.2.3 *flash, n*—thin film of material formed at the parting line of a part during molding, caused by unintentional opening of the mold or by defective mating surfaces.

3.2.4 *switchover point, n*—that point in the injection stage of the injection molding cycle when the control or level of the forwarding force applied to the screw and shot is switched from that used during injection to that used during pack/hold.

3.2.5 *velocity-pressure transfer point (VPT), n*—that point in the injection stage of the injection molding cycle as defined by pressure, position, or time when the rate of ram travel is switched from speed control to pressure control.

4. Summary of Practice

4.1 Many factors in the injection molding process can have an influence on the character of the moldings and the numerical values of test results. Among these are geometry, size, and temperature conditions of the heating chamber, pressures and speeds used, size, shape, and length of runners and gates, mold temperature and its uniformity, cavity surface finish, and timing cycles used along with the method of sequencing from stage to stage in the process. It is sometimes necessary to pretreat materials before molding. For materials that absorb water, drying under prescribed conditions is recommended and the user is advised to consult the applicable material standard for the conditions. This practice attempts to control some of these variables, nullify others, and report those that are necessary to obtain reproducible specimens. Definite stock and mold temperatures, based on the relevant material specifications or the material supplier's recommendations or past experience, and measured by standard techniques, are used for the molding process. By a sequence of operations the pressures, timing settings, and mode of control are established on the basis of their effects upon the molded part itself rather than upon any universal setpoints.

5. Significance and Use

5.1 It is well known that plastic test specimens molded under different conditions can have significantly different

properties. This practice is designed to minimize those differences by establishing operating protocols without being unnecessarily restrictive.

5.2 Always refer to the ASTM material specification or ISO designation for the material for recommended molding conditions. If not available, consult the material supplier.

5.3 This practice requires the use of adequate quantities of plastic material to find desirable operating conditions and to make the desired test specimens.

6. Apparatus

6.1 *Injection Molding Machine*—The machine selected for use must be equipped with appropriate devices for the control and measurement of pressures, all relevant temperatures, and the timing of certain cycle elements. Additional devices to monitor cavity pressure and ram position and velocity are very useful and desirable in the effective control of the injection molding process to give reproducible results. The capacity of the machine shall be such that the total shot weight (specimens plus sprue and runners) is 20 to 80 % of rated capacity. The injection machine must be capable of maintaining the proper injection velocity range if specified in the material standard.

NOTE 2—Heat-sensitive materials may require using the high end of the machine shot capacity range in order to minimize residence time of the melt in the barrel.

6.1.1 *Control System*—The various control systems shall maintain the operating parameters of the injection molding process from cycle to cycle within the following limits:

plastic melt, or stock temperature	±3°C
mold temperature	±3°C, ≤80°C ±5°C, >80°C
injection pressure	±2 %
hold pressure	±5 %
injection time	±0.1 s
hold time	±5 %
shot weight	±2 %

Suitable means of monitoring these parameters to ensure control within the above limits shall be utilized.

6.1.2 *Screw*—The design of the screw will be determined by the material being molded. A key criterion of screw design is to provide a melt that is as uniform as possible with respect to composition, temperature, and viscosity.

6.1.3 *Clamp*—The clamping force of the machine shall be high enough to prevent flashing at all operating conditions.

NOTE 3—The minimum clamp force required is the product of the highest possible cavity pressure and the projected surface area of the cavities (and runners). A force greater than this minimum will be required to prevent flashing.

6.2 *Mold*—The design of the mold is one of the more critical variables affecting specimen properties. Optimum reproducibility requires that identical molds be used by parties attempting to obtain comparable results. However, in the absence of identical molds, adherence to certain features of design will help to minimize differences between results obtained by different parties. It has been found that the use of unitized mold bases with interchangeable mold plates and gate inserts can provide a great deal of flexibility and provide rapid transitions between the moldings of different specimen configurations. (See Annex A1.)

6.2.1 *Cavity Layout*—Multi-cavity molds with identical cavities are recommended. The cavity layout shall be such that there is a uniform and symmetrical distribution of specimen surface area on the overall mold surface. The use of single cavity molds is discouraged. For large tensile test specimens and multipurpose bars, a two cavity “Z” layout is preferred, but a “T” layout is acceptable. For small tensile test specimens and bars, a four cavity double “T” layout is recommended. Other specimens have their unique cavity layout. (See [Annex A1](#).)

NOTE 4—ISO 294-1 states that the “Z” cavity runner layout is preferred over the “T” cavity runner layout.

NOTE 5—Family molds designed to produce more than one part configuration with each shot are not recommended. If molds of this nature are used, consideration shall be taken in the design to ensure that constant and uniform filling velocities are achieved in all cavities. Empirical techniques can be used to estimate these velocities. Additionally it is cautioned that the comparability of data obtained on specimens molded in this manner may be limited not only to a specific polymer type but also to specific rheological characteristics.

6.2.2 *Runners*—Runners will either be of the full-round type cut into both halves of the mold or of the trapezoidal type cut into only one of the mold halves. They shall be a minimum of 5 mm (0.2 in.) in diameter or of equivalent cross-sectional area if trapezoidal. A symmetrical cavity layout will permit identical runner systems to be used for each cavity and thus facilitate uniform filling of all cavities with all materials under all conditions. Runner draft angles for trapezoidal runners shall be from 10 to 30°. The diameter of the sprue shall be a minimum of 4 mm on the nozzle side.

NOTE 6—The runner system for small bars is longer than conventional to allow for approximately the same total shot volume between the different interchangeable cavity plates so that the shot size does not have to be adjusted significantly.

NOTE 7—If family molds with two or more identical specimen cavities or non-identical runner systems or if multi-cavity molds with non-identical runner systems are used, specimens from such cavities shall be identified and not be commingled for testing unless it has been demonstrated that there are no statistically significant differences in test results between the cavities.

NOTE 8—Limited data have shown that, for some materials (Polypropylenes, in particular), mechanical test values can be significantly affected by the cross sectional area of the runner. Specimens molded using the specified minimum runner size of 5 mm D (~20 mm²) exhibited lower values of most mechanical properties than specimens molded using runners with cross-sectional areas of 50 and 80 mm². Higher viscosity (lower MFR) materials appear to be more sensitive. This effect needs to be considered when comparing data obtained from different sources.

6.2.3 *Gates*—Unless otherwise stated for specific specimens, or material specifications, the gate depth for bar-type specimens shall be at least two-thirds the depth of the cavity and the gate width shall be at least two thirds the width of the cavity. Use the shortest possible gate length, with a maximum length of 3 mm (0.12 in.).

NOTE 9—Larger gates (width and depth) are preferred as they tend to produce parts whose physical properties are less sensitive to varying molding conditions than smaller ones.

NOTE 10—Certain materials require smaller gates to promote shear thinning so that mold cavities will be filled. However, many existing test methods call for somewhat smaller gates such as some of those listed in [Table 1](#). If it is necessary to use gates with alternative dimensions, these shall be reported in accordance with [8.1.6](#).

6.2.4 *Cavities*—Machining tolerances of the cavity will depend on the material to be molded and on the tolerances allowed in the specific test methods. Dimensioning of cavities with respect to anticipated shrinkage will result in cavity variations from molder to molder. It also requires different molds for every material to be molded. It is preferred to machine the cavity to the nominal dimensions of the specimen and to adjust the dimensions only when shrinkage leads to a specimen that is out of specification for the desired test method. Draft angles in the sidewalls of the cavity will probably be needed to facilitate part ejection but shall not be greater than 1° except in the shoulder of the multipurpose test specimen (ISO 20753) that shall not be greater than 2°. A maximum draft angle of ½ ° is preferred for all areas. All interior mold surfaces shall be finished to Society of Plastics Industry-Society of Plastics Engineers (SPI-SPE) No. A-3 or better. If cavity identification is required, this shall be located outside of the test area. It is recommended that the end of an ejector pin be used to incorporate an identifying symbol rather than the cavity surface.

6.2.5 *Ejector Pins*—Ejector pins shall be located where necessary, but not in the test area of the specimen. For tensile test specimens, it is recommended that the ejector pins be located at the wide tab ends (shoulders). For bars, it is recommended that the ejector pins be located at the “dead” end of the bar and outside of the central 20 mm length of the ISO mold type B (80 mm bar). For plates, the ejector pins shall be outside the central area of 50 mm diameter.

6.2.6 *Cavity Pressure Transducers*—Pressure transducers are not required, but if used shall be mounted in conjunction

TABLE 1 Gate Size Ranges for Common Test Specimens

Specimen	Test Method(s)	Nominal Thickness	Gate Depth		Gate Width	
			Minimum	Maximum	Minimum	Maximum
Type I tension specimen	D256 ^A , D638, D790 ^A , D1525 ^A , D6110 ^A	3.2	2.1	3.2	12.7	19
3.2 by 12.7 by 127 mm bar	D256, D648, D790, D1525, D6110	3.2	2.1	3.2	8.5	12.7
6.4 by 12.7 by 127 mm bar	D256, D648, D790, D1525, D6110	6.4	4.3	6.4	8.5	12.7
3.2 by 51 mm disk	D570	3.2	2.1	3.2	3.2	^B
3.2 by 102 mm disk	D955	3.2	2.1	3.2	12.7	^B
Multipurpose test specimen	ISO 20753	4	2.7	4	13.3	20

^AThis procedure can be conducted using the center portion of this specimen geometry.

^BBecause of the non-linear configuration of these specimens, only a minimum gate width is specified.

with an ejector pin or directly into the cavity, coplanar to the mold surface. When utilized, pressure transducers are typically used to provide additional monitoring or control the mold filling characteristics. In the case of plates, the pressure transducer is mandatory for measurement of molding shrinkage only and the mounting shall be as shown for ISO mold type D in [Annex A1](#).

NOTE 11—Transducers located in the main runner will not provide data for monitoring or controlling cavity flow.

6.2.7 Mold Cooling—Coolant channels shall be designed so as to limit point-to-point surface temperature differences to a maximum of 5°C. The channels shall be located in such a way that each of the cavities is cooled in an identical manner.

NOTE 12—Nonsymmetrical family molds shall follow this design criterion as closely as possible.

NOTE 13—Fittings used to connect the coolant channel openings to the recirculating system may be of the self-sealing quick-disconnect type. For maximum cooling efficiency the flow of coolant through the channels should be turbulent, as indicated by a Reynolds number >5000.

7. Procedure

7.1 Consistency of Test Specimens—When operating on an automatic cycle with adequate control of the parameters listed in [6.1.1](#), it is necessary to obtain consistent test specimens.

7.2 Feed—Condition plastic material prior to molding as required in the relevant material standard or according to the material supplier's recommendation if no standard covers the material. In the case of extreme moisture sensitivity, maintain drying conditions in the molding machine feed hopper itself. Avoid exposing material to an atmosphere with temperatures significantly below ambient temperature to prevent condensation of moisture onto plastic material.

7.3 Setting Molding Conditions—Set molding conditions as referenced in the relevant material standard. If the material standard does not contain recommended molding conditions, then consult the material supplier for recommendations. The most critical molding parameters are melt temperature, mold temperature and average injection velocity. Others that may be specified include first and second stage injection pressure, and screw back pressure; first and second stage injection times; cure/cool, mold open, melt decompression and total cycle times; screw rotation speed and cushion/pad interval.

7.3.1 Melt Temperature—Choose a melt temperature based on the relevant material standard, or the recommendations of the material supplier, or best available information. Adjust the barrel temperature controller setpoints in order to obtain the desired melt temperature. These settings will typically be lower than the target melt temperature. Measure this temperature on cycle after thermal equilibrium has been reached by actually taking the temperature of a purge shot (preferably held in an insulated container) with a needle-type pyrometer having an accuracy of $\pm 2.0^{\circ}\text{C}$ (3.8°F). Move the needle about constantly in the plastic mass and make a sufficient number of measurements to establish a reliable average. Preheating of the needle to near the measured temperature will allow faster, and thus more reliable measurements to be made. Perform frequent checks. A non-contact temperature measuring device may also be used provided it has been properly calibrated for the molten

material. The melt temperature may alternatively be measured by means of a suitable temperature sensor in the molten plastic flow stream provided the values obtained are the same as those by the free shot method.

NOTE 14—Under a fixed set of operating conditions of cycle and shot size there will generally be a constant difference between the observed plastic temperature and the cylinder-wall temperature or the setpoint temperature. This difference will vary as conditions are changed.

7.3.2 Mold Temperature—Choose a mold temperature based on the relevant material standard or the supplier's recommendation. The temperature shall be measured in accordance with Practice [D957](#) with a calibrated surface-type pyrometer to an accuracy of $\pm 2.0^{\circ}\text{C}$ (3.8°F) after the system has obtained thermal equilibrium and immediately after opening the mold and ejecting the part. Carry out measurements of the mold cavity surface temperature at several points on both the moveable and stationary mold halves. The molding process shall be recycled a minimum of ten cycles between each set of multiple readings. Calculate the mold temperature as an average of these readings.

7.3.3 Average Injection Velocity—Unless otherwise specified, an average injection velocity of 200 ± 100 mm/s is suitable for most materials in preparing tensile specimens and bars. For other specimens, average injection velocity is chosen to give similar fill times as with tensile and bar specimens.

7.3.4 Molding Pressures—Most injection molding machines use hydraulic pressure as the motive force for the various machine movements. In different machines valves are used to control the level of pressure, the flow rate of fluid, the length of time at a given pressure, or combinations of these parameters. Filling of the mold is typically done with a high pressure (first stage) in order to achieve the desired short fill times. However, since this high pressure may cause flashing of the mold after the cavity is filled, and since release of the pressure after filling would allow polymer to flow out of the mold, a usually lower second stage, or hold pressure, is begun when the mold is essentially filled. The point in the cycle when this transition is made is called the "switchover point" or the velocity-pressure transfer point in those machines where the first stage is speed controlled. Control of these functions is done using a variety of means involving timers, position sensors, pressure transducers, or combinations thereof.

7.3.4.1 First Stage Injection Pressure—After choosing a melt and mold temperature from the relevant material specification or by other means the first stage injection pressure may be determined by the following procedure. Set the second stage pressure to zero and incrementally increase the first stage pressure from an obviously low value where long fill times and incompletely filled cavities occur until the fill time is reduced to its target value and the cavities are filled. The readouts on the timer, position sensor, or pressure transducer should be noted as control parameters for the final cycle. Maintain as constant a screw forward speed during the injection period as possible.

7.3.4.2 Second Stage Injection Pressure—Having chosen the melt and mold temperatures, the first stage injection pressure and its means of control, set the second stage pressure by adjusting the second stage pressure upward until a satisfactory part is produced (make certain to consult the material

specification for any guidance on pressures). This is indicated mainly by surface appearance, that is, lack of sink marks, voids, flash, etc. Second stage pressure should be maintained constant until polymer in the gate of the cavity is sufficiently cool so that flow through the gate is no longer possible or the “gate freezes.” This can be determined by increasing the setpoint of the timer until a constant part weight is obtained.

7.3.4.3 Back Pressure—After the second stage time has expired the screw will begin to rotate to plasticate the polymer for the next injection cycle. As molten polymer is conveyed forward ahead of the screw, the screw will retract against the resulting pressure. High back pressure will cause excessive working of the polymer, high melt temperatures, and drooling of polymer from the nozzle. It will also cause breakdown of any fibrous fillers. Low back pressure may cause unmelted polymer or nonuniform polymer temperatures or inadequately mixed polymers where additives are used. Choose a back pressure that avoids the difficulties of the extremes described.

7.3.5 Molding Cycle—Injection-molding machines of different types and produced by different manufacturers have different means of controlling the molding cycle. Fig. 1 illustrates the relationship of the different components of the cycle. Certain cycle components will be controlled by various means on the different machines. Although the cooling and melt plastication functions may affect the properties of test specimens, the most important function to control is the injection step. The driving force in the injection step is commonly hydraulic pressure. Different machines and control systems will control this force with valves actuated by timers, pressure setpoints, position transducers, etc. Whichever method of control is used, it will require reproducible fill timers (± 0.1 s) to achieve reproducible parts. In general, the minimum practical fill time is desired.

7.3.5.1 First Stage and Second Stage—Set the available means of control, including screw position, cavity pressure, screw pressure, and timer, to the value determined during manipulation of the injection pressures as described in 7.3.4.1 and 7.3.4.2.

7.3.5.2 Cure/Cool Time—Choose a cooling time that will allow the part to be ejected from the mold without distortion. A longer cooling time will have the adverse effect of increasing the melt residence time in the barrel.

7.3.5.3 Screw Rotation Speed—Choose a minimum screw speed in order to use nearly all of the time available during the

cure/cool part of the cycle. Slower screw speeds generally provide greater uniformity of the melt with respect to viscosity and temperature.

7.3.5.4 Cylinder Decompression—Most injection machines will decompress the melt after plastication by a further small retraction of the screw after rotation has ceased. This is controlled by either a position sensor or a timer. Set the available means to the lowest setting that will eliminate drool from the nozzle when the carriage is subsequently pulled away from the mold prior to mold opening.

7.3.5.5 Mold Open Time—Choose a time that will allow the mold faces to part, the ejection mechanism to occur, and the part to safely fall out. It is advisable to allow a safety factor so that minor problems during ejection will not cause interruption of the cycle or damage to the mold.

7.3.5.6 Total Cycle Time—Measure the total cycle time with a stopwatch between the same point of successive cycles.

7.3.6 Cushion/Pad—It is important to provide a small amount of excess melt in front of the screw so that it never fully completes the injection stroke and that the full second stage injection pressure is maintained on the molten material. This is referred to as the “cushion” or “pad” and is usually measured by its length in the barrel. It is important that this cushion be kept uniform from one cycle to the next. A minimum length of 3 mm is generally needed and it should not exceed 6 mm.

7.4 Begin to collect specimens only after molding cycle equilibrium has been achieved.

7.5 Allow test specimens removed from the mold to cool gradually and uniformly to room temperature in order to avoid differences in test results due to treatment of individual specimens. For materials sensitive to atmospheric exposures, specimens should be protected by storing in impermeable containers.

8. Report

8.1 Report the following information using the appropriate units:

- 8.1.1 Date, place, and time of molding,
- 8.1.2 Description of material being molded (type, grade, color, lot number),
- 8.1.3 Pre-molding treatment of material,
- 8.1.4 Identification of the mold being used (type, number of cavities),
- 8.1.5 Type and number of specimens molded,
- 8.1.6 Description of the cavity gating,
- 8.1.7 Make, size (clamp and shot capacity), and type of machine used,
- 8.1.8 Weight of shot (including sprues and runners), and weight of specimen,
- 8.1.9 All temperature controller setpoints,
- 8.1.10 Temperatures, including:
 - 8.1.10.1 Melt temperature,
 - 8.1.10.2 Mold temperature, stationary half, and
 - 8.1.10.3 Mold temperature, fixed half,
- 8.1.11 Pressures, including:
 - 8.1.11.1 First stage injection pressure and
 - 8.1.11.2 Second stage injection pressure,

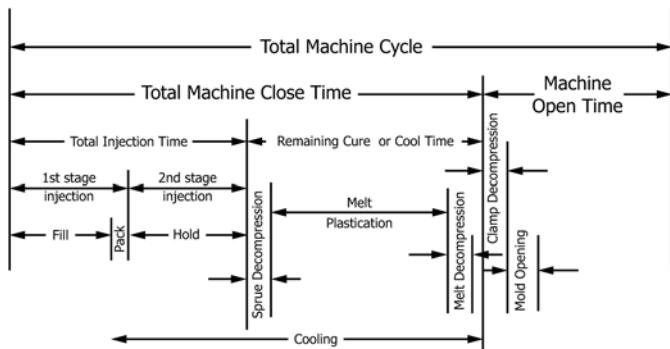

FIG. 1 Molding Cycle Components

- 8.1.11.3 Back pressure,
- 8.1.12 Molding cycle times, including:
 - 8.1.12.1 First stage injection time (s),
 - 8.1.12.2 Second stage injection time (s),
 - 8.1.12.3 Cure/cool time (s),
 - 8.1.12.4 Mold open time (s),
 - 8.1.12.5 Melt decompression time (s) or distance (mm),
 - 8.1.12.6 Total cycle time (s),

- 8.1.13 Screw speed (r/min),
- 8.1.14 Cushion/pad, and
- 8.1.15 Average injection velocity.

9. Keywords

9.1 injection-molding; mold design; test specimen preparation; thermoplastics

ANNEX

(Mandatory Information)

A1.

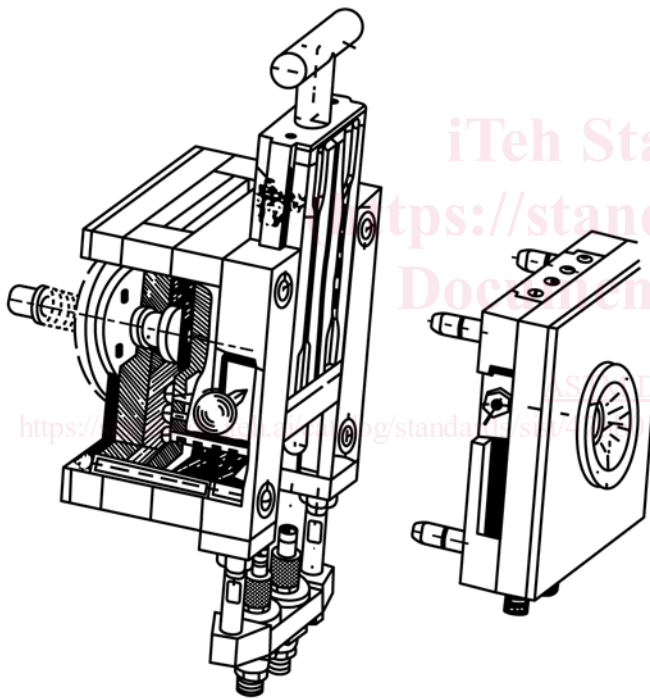

FIG. A1.1 Example of a Unitized Mold Base With Interchangeable Two Cavity Tensile Bar Insert

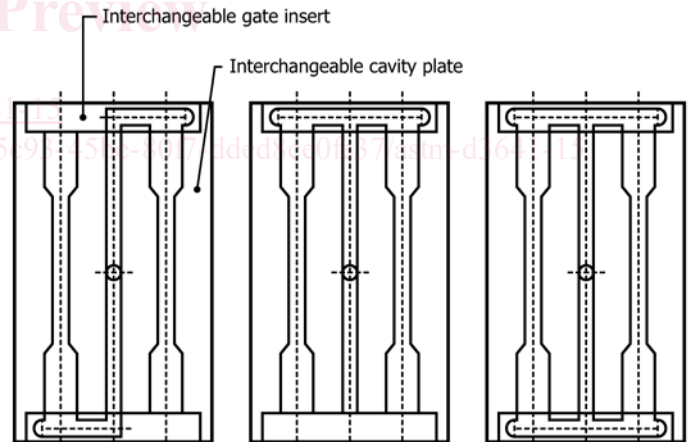
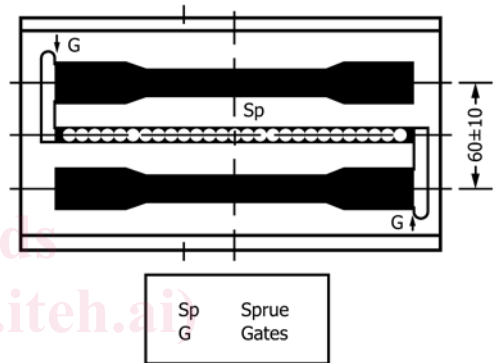

FIG. A1.2 Cavity and Runner Layout for Large Tensile Specimens