



Designation: **E643–09 E643 – 15**

Standard Test Method for Ball Punch Deformation of Metallic Sheet Material¹

This standard is issued under the fixed designation E643; the number immediately following the designation indicates the year of original adoption or, in the case of revision, the year of last revision. A number in parentheses indicates the year of last reappraisal. A superscript epsilon (ϵ) indicates an editorial change since the last revision or reappraisal.

INTRODUCTION

The ball punch deformation test is used for evaluating the ductility of metallic sheet materials. The test involves biaxial stretching of a constrained test specimen. Ideally, no draw-in of flange metal from under the hold-down occurs. The sheet metal test specimen is bulged at a specified rate until the ~~load~~ force drops or until either necking or fracture occurs; the test is then terminated. Ball punch (penetrator) movement to ~~drop-in-load~~ drop-in-force or necking or fracture is the test result. It is known that test results may vary with hold-down force, lubrication, and criterion for determining the end point of the test.

1. Scope

~~1.1 This test method covers the procedure for conducting the ball punch deformation test for metallic sheet materials intended for forming applications. The test applies to specimens with thicknesses between 0.008 and 0.080 in. (0.20 and 2.00 mm).~~

1.1 The values stated in inch-pound units are to be regarded as the standard. This test method covers the procedure for conducting the ball punch deformation test for metallic sheet materials intended for forming applications. The test applies to specimens with thicknesses between 0.008 and 0.080 in. (0.2 and 2.0 mm).

NOTE 1—The ball punch deformation test is intended to replace the Olsen cup test by standardizing many of the test parameters that previously have been left to the discretion of the testing laboratory.

NOTE 2—The modified Erichsen test has been standardized in Europe. The main differences between the ball punch deformation test and the Erichsen test are the diameters of the penetrator and the dies. Erichsen cup heights are given in SI units.

1.2 The values stated in inch-pound units are to be regarded as standard. The values given in parentheses are mathematical conversions to SI units that are provided for information only and are not considered standard.

1.3 *This standard does not purport to address all of the safety concerns, if any, associated with its use. It is the responsibility of the user of this standard to establish appropriate safety and health practices and determine the applicability of regulatory limitations prior to use.*

2. Referenced Documents

2.1 *ASTM Standards:*²

[E177 Practice for Use of the Terms Precision and Bias in ASTM Test Methods](#)

[E691 Practice for Conducting an Interlaboratory Study to Determine the Precision of a Test Method](#)

2.2 *National Institute of Standards and Technology Document:*³

[NIST Handbook 91 Experimental Statistics](#)

3. Terminology

3.1 *Definitions of Terms Specific to This Standard:*

3.1.1 *cup height*, the height of the formed cup at the end point of the test.

¹ This test method is under the jurisdiction of ASTM Committee E28 on Mechanical Testing and is the direct responsibility of Subcommittee E28.02 on Ductility and Formability.

Current edition approved June 1, 2009; May 1, 2015. Published June 2009; June 2015. Originally published in 1978. Last previous edition approved in 2000 as E643-84(2000) which was withdrawn March 2009 and reinstated in June 2009. DOI: 10.1520/E0643-09-09. DOI: 10.1520/E0643-15.

² For referenced ASTM standards, visit the ASTM website, www.astm.org, or contact ASTM Customer Service at service@astm.org. For *Annual Book of ASTM Standards* volume information, refer to the standard's Document Summary page on the ASTM website.

³ Available from National Institute of Standards and Technology (NIST), 100 Bureau Dr., Stop 1070, Gaithersburg, MD 20899-1070, <http://www.nist.gov>.

4. Significance and Use

4.1 The ball punch deformation test is widely used to evaluate and compare the formability of metallic sheet materials. Biaxial stretching is the predominant mode of deformation occurring during the test and, therefore, the results are most often used to rate or compare materials that are to be formed mainly by stretching. However, precise correlations between the cup height as determined by this test and the formability of a sheet material under production conditions have not been established.

4.2 It is recognized that the cup heights for specimens from the same sample may vary with differences in magnitude of hold-down force, lubrication, and method of end point determination. The procedures described in Sections 5, 7.1, and 7.3 will minimize these variations.

5. Apparatus

5.1 *Cupping Machines* (Fig. 1) —Any machine used for ball punch deformation tests shall be equipped to hold the specimen with a minimum force of 2200 lbf (9800 N). It shall have a spherical-ended penetrator capable of forcing the central portion of the specimen through the die until the end point of the test occurs (see 7.3).

5.1.1 Variation in hold-down force is a source of variation in cup height. For machines not equipped to measure the hold-down force, the magnitude of the force should be established.

5.1.2 The magnitude of the hold-down force shall be such that no appreciable draw-in occurs.

5.1.3 The machine shall be provided with a displacement indicator to measure cup height.

5.2 *Displacement Indicator*—The displacement indicator shall monitor the ball penetrator movement and the scale shall be graduated such that displacement can be measured to within at least ± 0.0025 in. (when using indicators reading in SI units, the displacement shall be measured to within at least ± 0.05 mm).

5.3 Tooling:

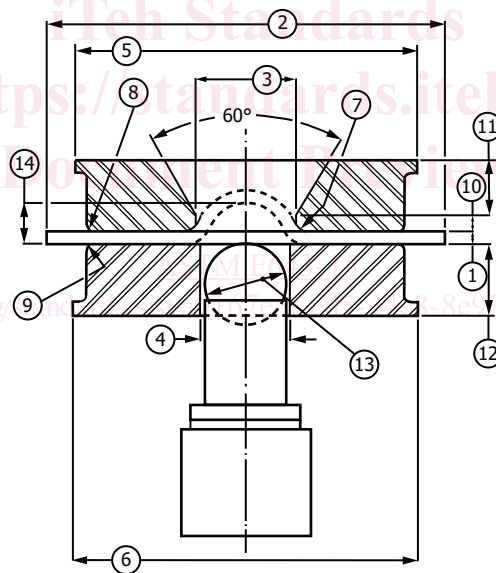

Key	Dimensions	
	in.	mm
(1) Thickness of test piece	full thickness	full thickness
(2) Width of test piece (minimum)	3.5	89
(3) Bore Diameter of top die	See 6.3.	See 6.3.
(4) Bore Diameter of bottom die	1 ± 0.004	25.4 ± 0.1
(5) External diameter of top die (approximate)	3.5	89
(6) External diameter of bottom die (approximate)	3.5	89
(7) Corner radius of interior top die	0.032 ± 0.002	0.81 ± 0.05
(8) Corner radius of exterior top die	0.032	0.81
(9) Depth of bore of top die	0.032	0.81
(10) Depth of bore of top die	0.197 ± 0.010	5.00 ± 0.025
(11) Thickness of top die (minimum)	0.78	20
(12) Thickness of bottom die (minimum)	0.78	20
(13) Diameter of spherical end of penetrator ^A	0.875 ± 0.002	22.2 ± 0.05
(14) Cup Height	Cup Height	Cup Height

^A "Olsen Ball, 22.22 mm (7/8 in.); "Erichsen" Ball, 20mm.

FIG. 1 Ball Punch Deformation Test Tooling