



Designation: **E2661/E2661M – 10 E2661/E2661M – 15**

Standard Practice for Acoustic Emission Examination of Plate-like and Flat Panel Composite Structures Used in Aerospace Applications¹

This standard is issued under the fixed designation E2661/E2661M; the number immediately following the designation indicates the year of original adoption or, in the case of revision, the year of last revision. A number in parentheses indicates the year of last reapproval. A superscript epsilon (ϵ) indicates an editorial change since the last revision or reapproval.

1. ~~Scope~~ Scope*

1.1 This practice covers acoustic emission (AE) examination or monitoring of panel and plate-like composite structures made entirely of fiber/polymer composites.

1.2 The AE examination detects emission sources and locates the region(s) within the composite structure where the emission originated. When properly developed AE-based criteria for the composite item are in place, the AE data can be used for nondestructive examination (NDE), characterization of proof testing, documentation of quality control or for decisions relative to structural-test termination prior to completion of a planned test. Other NDE methods may be used to provide additional information about located damage regions. For additional information see [X1.1 in Appendix X1](#).

1.3 This practice can be applied to aerospace composite panels and plate-like elements as a part of incoming inspection, during manufacturing, after assembly, continuously (during structural health monitoring) and at periodic intervals during the life of a structure.

1.4 This practice is meant for fiber orientations that include cross-ply, angle-ply laminates or two-dimensional woven fabrics. This practice also applies to 3-D reinforcement (for example, stitched, z-pinned) when the fiber content in the third direction is less than 5 % (based on the whole composite).

1.5 This practice is directed toward composite materials that typically contain continuous high modulus greater than 20 GPa [3 Msi] fibers.

1.6 The values stated in either SI units or inch-pound units are to be regarded separately as standard. The values stated in each system may not be exact equivalents; therefore, each system shall be used independently of the other. Combining values from the two systems may result in non-conformance with the standard.

1.7 *This standard does not purport to address all of the safety concerns, if any, associated with its use. It is the responsibility of the user of this standard to establish appropriate safety and health practices and determine the applicability of regulatory limitations prior to use.*

2. Referenced Documents

2.1 *ASTM Standards:*²

- [E543 Specification for Agencies Performing Nondestructive Testing](#)
- [E976 Guide for Determining the Reproducibility of Acoustic Emission Sensor Response](#)
- [E1067 Practice for Acoustic Emission Examination of Fiberglass Reinforced Plastic Resin \(FRP\) Tanks/Vessels](#)
- [E1106 Test Method for Primary Calibration of Acoustic Emission Sensors](#)
- [E1316 Terminology for Nondestructive Examinations](#)
- [E1781 Practice for Secondary Calibration of Acoustic Emission Sensors](#)
- [E2533 Guide for Nondestructive Testing of Polymer Matrix Composites Used in Aerospace Applications](#)

¹ This practice is under the jurisdiction of ASTM Committee E07 on Nondestructive Testing and is the direct responsibility of Subcommittee E07.04 on Acoustic Emission Method.

Current edition approved June 1, 2010/June 1, 2015. Published July 2010/July 2015. Originally approved in 2010. Last previous edition approved in 2010 as E2661/E2661M-10. DOI:10.1520/E2661_E1661M-15.

² For referenced ASTM standards, visit the ASTM website, www.astm.org, or contact ASTM Customer Service at service@astm.org. For *Annual Book of ASTM Standards* volume information, refer to the standard's Document Summary page on the ASTM website.

*A Summary of Changes section appears at the end of this standard

2.2 Other Documents:

- [ANSI/ASNT CP-189 ASNT Standard for Qualification and Certification of Nondestructive Testing Personnel](#)³
[ISO 9712 Non-destructive Testing—Qualification and Certification of NDT Personnel](#)⁴
[NAS-410 NAS Certification and Qualification of Nondestructive Personnel \(Quality Assurance Committee\)](#)⁵
[SNT-TC-1A Recommended for Personnel Qualification and Certification of Nondestructive Testing Personnel](#)³

3. Terminology

3.1 *Definitions*—See Terminology [E1316](#) for general terminology applicable to this practice.

3.2 *Definitions of Terms Specific to This Standard:*

3.2.1 *characteristic damage state*—transverse matrix cracking during the virgin loading of a composite; often resulting in reaching a limit of the crack density prior to reaching failure. Results in a reduction of stiffness of the composite. For additional information see [X1.2](#).

3.2.2 *flat panel composite*—any fiber reinforced composite lay-up consisting of laminas (plies) with one or more orientations with respect to some reference direction that result in a two-dimensionally flat article of finite thickness (typically relatively thin).

3.2.3 *plate-like composite*—any fiber-reinforced composite lay-up consisting of laminas (plies), which is not strictly flat, but for purposes of the AE examination, can be considered as a two-dimensional (2-D) structural plate for wave propagation and for location of the region of AE source origin. Applies for a minimum radius of curvature of greater than about 2 m (6 ft), so curvature does not change group velocities.

3.2.4 *quasi-isotropic lay-up*—a plate where the group velocities of both the fundamental modes have been shown to be independent of propagation direction. For example: [+45/-45/0/90]_s⁶.

3.2.5 *wideband AE sensors*—wideband (broadband) AE sensors, when calibrated according to [E1106](#) or [E1781](#), exhibit displacement or velocity response over several hundred kHz with a coefficient of variation of the response in dBs that does not exceed 10 %.

3.2.6 *wideband-based (modal) AE techniques*—AE techniques with wideband AE sensors that subject waveforms of the signals to combined time and frequency analysis to obtain mode-based arrival times (for source location calculations) and modal amplitudes for potential source identification. Note that mode-based arrival times can also be obtained with resonant sensors, but only at certain experimentally determined frequencies.

4. Summary of Practice

4.1 This practice consists of subjecting flat composite panels or plate-like composite structures to loading or stressing while monitoring with sensors that are sensitive to AE (transient displacement waves) caused by the creation of micro-damage, growing flaws and friction-based sources. For additional information see [X1.3](#).

4.2 This practice provides an approach to determine the local regions of origin of the AE sources and any potential local regions of large accumulation(s) of AE sources.

4.3 This practice can provide an approach to use AE-based criteria to determine the significance of flaws.

5. Significance and Use

5.1 This AE examination is useful to detect micro-damage generation, accumulation and growth of new or existing flaws. The examination is also used to detect significant existing damage from friction-based AE generated during loading or unloading of these regions. The damage mechanisms that can be detected include matrix cracking, fiber splitting, fiber breakage, fiber pull-out, debonding and delamination. During loading, unloading and load holding, damage that does not emit AE energy will not be detected.

5.2 When the detected signals from AE sources are sufficiently spaced in time so as not to be classified as continuous AE, this practice is useful to locate the region(s) of the 2-D test sample where these sources originated and the accumulation of these sources with changing load and/or time.

5.3 The probability of detection of the potential AE sources depends on the nature of the damage mechanisms, flaw characteristics and other aspects. For additional information see [X1.4](#).

5.4 Concentrated damage in fiber/polymer composites can lead to premature failure of the composite item. Hence, the use of AE to detect and locate such damage is particularly important.

³ Available from American Society for Nondestructive Testing (ASNT), P.O. Box 28518, 1711 Arlingate Ln., Columbus, OH 43228-0518, <http://www.asnt.org>.

⁴ Available from International Organization for Standardization (ISO), 1, ch. de la Voie-Creuse, CP 56, CH-1211 Geneva 20, Switzerland, <http://www.iso.org>.

⁵ Available from Aerospace Industries Association of America, Inc., 1250 Eye St., NW, Washington, DC 20005.

⁶ Lei Wang, F.G. Yuan, "Group velocity and characteristic wave curves of Lamb waves in composites: Modeling and experiments," Composites Science and Technology 67 (2007) 1370–1384.

5.5 AE-detected flaws or damage concentrated in a certain region may be further characterized by other NDE techniques (for example, visual, ultrasonic, etc.) and may be repaired as appropriate. Repair procedure recommendations and the subsequent examination of the repair are outside the scope of this practice. For additional information see X1.5.

5.6 This practice does not address sandwich core, foam core or honeycomb core plate-like composites due to the fact that currently there is little in the way of published work on the subject resulting in a lack of a sufficient knowledge base.

5.7 Refer to Guide E2533 for additional information about types of defects detected by AE, general overview of AE as applied to polymer matrix composites, discussion of the Felicity ratio (FR) and Kaiser effect, advantages and limitations, AE of composite parts other than flat panels, and safety hazards.

6. Basis of Application—Personnel Qualification—Contractual Agreement

6.1 The following items are subject to contractual agreement between the parties using or referencing this practice.

6.2 *Personnel Qualification*—Unless contractually agreed otherwise, personnel performing examinations to this practice shall be qualified in accordance with a nationally or internationally recognized NDT personnel qualification practice or standard such as ANSI/ASNT-CP-189, SNT-TC-1A, NAS-410, ISO 9712, or a similar document. They shall be certified by the employer or certifying agency, as applicable. The practice or standard used and its applicable revision shall be identified in the contractual agreement between the using parties.

6.3 *Qualification of Nondestructive Agencies*—Unless contractually agreed otherwise, NDT agencies shall be qualified and evaluated as described in E543. The applicable edition of E543 shall be specified in the contractual agreement.

6.4 *Procedure and Techniques*—The procedures and techniques to be utilized shall be as specified in the contractual agreement. In particular, the contractual agreement should state whether full monitoring of the test sample is required or if only partial monitoring of certain expected critical areas is required.

6.5 *Timing of Examination*—The timing of examination shall be in accordance with 1.3, unless otherwise specified.

6.6 *Reporting Criteria*—Reporting criteria for the examination results shall be in accordance with Section 12, unless otherwise specified.

7. Apparatus

7.1 Refer to Fig. 1 for a typical AE system block diagram showing key components.

7.2 *AE Sensors:*

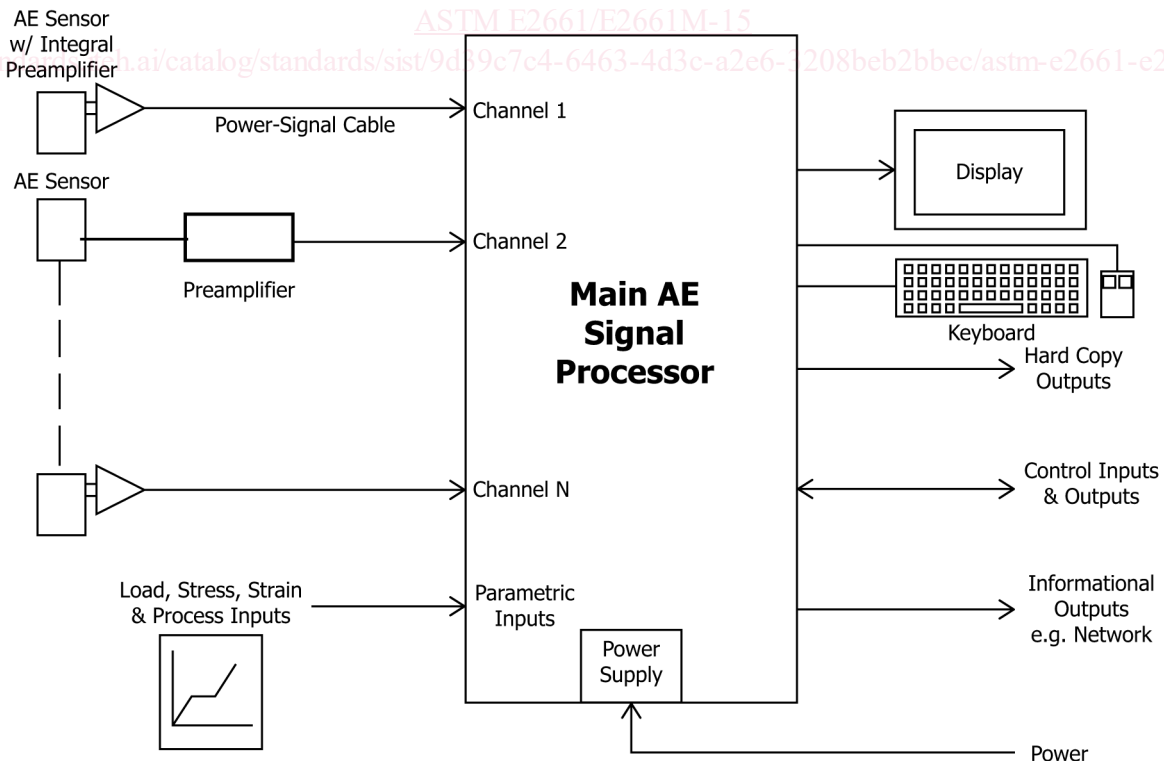

FIG. 1 AE System Block Diagram

7.2.1 The selection of a wideband or resonant sensor is described here. For information on the frequency content of AE waves see **X1.6**. For a scientific method to select sensors whose best frequency response corresponds to the frequency range of the highest amplitudes of the AE waves see **X1.7**.

7.2.1.1 Wideband sensors can be used along with waveform recording to enhance AE data analysis by the application of wideband-based AE techniques. A wideband sensor should be chosen with relatively flat response (**E1106** or **E1781**) from about 50 kHz to 400 kHz. For additional information see **X1.7** for plates less than 2-mm thick and **X1.8**.

7.2.1.2 If resonant sensors are used, the best choice is a sensor with its primary resonance in the lower portion of a 50 kHz to 400 kHz frequency band. Sensors with a lower frequency resonance of about 25 kHz to 50 kHz can be used to increase sensor spacing (for example when a limited number of AE channels are available [see **E1067**]) in AE testing of composites, but such sensors increase the likelihood that unwanted extraneous noise will be recorded. To minimize the effects of airborne noise the lower resonant-frequency sensors can be wrapped with sound absorbing material.

7.2.2 Sensors should be shielded against electromagnetic interference (EMI) through proper design practice or differential (anti-coincidence) element design, or both.

7.2.3 Sensors should have omni-directional response, with directional variations not exceeding 4 dB from the average peak response of the set of sensors.

7.3 *Sensor Couplant:*

7.3.1 The sensors must be acoustically coupled (to remove air from between the sensor face and the composite surface) directly to the test sample. Commercially available couplants for ultrasonic flaw detection may be used. Silicone-based high-vacuum grease has been found to be particularly suitable, but it may not be desirable for all test locations and all test samples. Adhesives may also be used. Note: the sensor attachment procedure as well as the couplant or adhesive may require approval prior to sensor installation due to special requirements for materials placed in contact with composite structures (compatibility and/or contamination control).

7.3.2 Couplant selection should be made to minimize changes (for example, drying out of the couplant or movement of the couplant due to gravity over the range of test temperatures and test time duration) in coupling sensitivity during a complete examination.

7.4 *Sensor Attachment Apparatus:*

7.4.1 *Adhesives*—Various adhesives can be used to attach sensors and provide acoustic coupling. The bond line created by the adhesive must be much thinner than the shortest wavelengths of interest. Adhesives such as two-part epoxies, silicone adhesives, and cyanoacrylates have been successfully used for attaching sensors. Sensors attached with some adhesives can be difficult to remove without damaging the sensor or the examination sample. Also, due to the larger design deformations of composite materials (relative to metals designed to operate in their elastic range), adhesively bonded sensors may debond during test sample stressing or during thermal cycling of the test sample.

7.4.2 *Tape*—Elastic adhesive tapes have been successfully used for mounting transducers (for example, taping the sensors to one side of a large composite panel).

7.4.3 *Elastic Bands*—An elastic band (for example, rubber bands) can be placed over the sensor and anchored to the test sample to hold sensors in place.

7.4.4 *Spring Loaded*—Sensors may be spring loaded against the test sample by fixturing (that does not generate extraneous noise during testing). Such mounting must be able to accommodate the deformation of the test sample without losing acoustic coupling.

7.4.5 It is generally unacceptable to modify a composite by machining a “flat” to mount a sensor (creates potential damage). Thus, with surfaces that are rough, or have curvature, or both, it is typical that the sensors will have less sensitivity than when they are mounted on flat and smooth surfaces.

7.4.6 This practice does not address the use of waveguides for fiber/polymer composites.

7.5 *System Cabling:*

7.5.1 *Sensor Cable*—AE systems typically use a standard low noise shielded coaxial cable that is not susceptible to triboelectric noise (from mechanical movement of the cable) for this connection, due to its ability to shield the low level signal out of the sensor from electromagnetic interference. The cable should be kept short, 1-2 m [3-6 ft], to reduce attenuation of the signal, to reduce the length of cable possibly exposed to electromagnetic interference and to create the best signal-to-noise ratios. If it is absolutely necessary to use a longer length during testing, the effect of the longer length on the attenuation of signal amplitudes should be evaluated (for example, by PLBs with a short cable length versus the longer length). If the loss is greater than 6 dB, the measured loss should be compared to the signal amplitudes obtained during pre-testing to conclude whether the loss is acceptable. Note that integral preamplifier sensors eliminate issues resulting from sensor cables, but in some approaches such sensors increase the size and mass of the sensors and impact the mounting of this type of sensor.

7.5.2 *Power-Signal Cable*—The cable and connectors that provide power to the preamplifiers and conduct the preamp-amplified signals to the main processor shall be shielded against electromagnetic interference. The typical standard coaxial cabling used in AE testing is RG-58 at about 50 Ω impedance. Dual and quad shielded cable is also available to improve noise rejection in particularly noisy (electromagnetic) environments. When RG-58 is used, the maximum recommended length is 330 m [1000 ft] to avoid excessive signal attenuation. Smaller diameter cables, RG-174 (50 Ω impedance), can be used if the cable diameter is a

concern for a bundle of cables, but the effects of possible EMI from external sources and cross talk between cables must be accounted for. Some systems may use 75 Ω coax cables such as RG-59. In all cases, the operator should follow the AE equipment manufacturer's recommendations.

7.6 Preamplifier:

7.6.1 The preamplifier converts the high impedance signal from the sensor to a low impedance signal and amplifies the signals to acceptable levels to allow the signal to be transmitted over longer distances of cable. The preamplifier also reduces the sensitivity to extraneous electromagnetic signals in the power-signal cable.

7.6.2 Integral preamplifiers (within the sensor case) reduce the sensitivity to extraneous electrical noise, and they perform as stated in 7.6.1.

7.6.3 The preamplifier should include a filter with a bandwidth that includes the useable frequency range of the sensors being used. Typically a filter bandwidth of 50 kHz to 400 kHz or high-pass filters with a low cut-off frequency in this range may be used (the low cut-off frequency is altered if a low frequency resonant sensor is used). If extraneous mechanical noise is present, then the lower frequency may need to be increased (but ideally it should remain at least 15 to 20 kHz below the resonant frequency of the sensor).

7.6.4 Preamplifier gain should vary not more than ± 1 dB within the actual frequency and temperature ranges.

7.6.5 The input capacitance of the preamplifier should be low (typically less than 25 pf) to limit the loss of sensor sensitivity.

7.6.6 The preamplifier output should have a noise level not greater than 5 μ V RMS (root-mean-square) (referred to a shorted input or a 50-ohm terminator at the input) within the actual frequency range.

7.6.7 The output impedance of the preamplifier should match the input impedance of the signal processing unit (typically 50 ohms).

7.6.8 Preamplifiers should be shielded from electromagnetic interference.

7.6.9 Due to possible high amplitude AE signals in some composites, care should be exercised to eliminate voltage saturation of the signals in the preamplifier. For example, if peak signal amplitudes are ≥ 97 dB_{AE}, then a preamplifier that has 40 dB of gain and a maximum output of 20 V_{pp} into 50 Ω may experience saturation. In such a case, a preamplifier with a lower amplification gain should be used, for example 20 dB. Alternatively, lower sensitivity sensors can be used or preamplifiers with a larger maximum output voltage can be used.

7.7 Power Supply:

7.7.1 A stable, grounded, and reliable power supply that meets the signal processor manufacturer's specification should be used.

7.8 Main AE Signal Processor:

7.8.1 The main processor and computer with software (with sufficient independent channels) should have electronic circuitry and software through which signals from the sensors will be processed. The main processor normally adds additional gain and appropriate frequency filtering. It shall be capable of processing each AE hit to determine a threshold-based arrival time and the hits duration, counts, peak amplitude and energy on each independent channel. In addition, it should process the average signal level (ASL) or the root-mean-square (RMS) voltage on each channel. In order to record valid AE data, its capability, to process hits and store the processed AE hit data must exceed the rate at which AE hits will be generated in the examination. Finally, it should process and associate real-time parametric measurement values (for example, time-driven data such as load, strain, temperature, etc.) with each hit.

7.8.2 It may include hardware with sufficient dynamic range (at least 12-bit) and sufficient digitization rates to properly digitize each AE hit. It should provide capability to store the digitized waveform data and provide the ability to review the waveforms and perform appropriate data analysis. For this much greater amount of data, its capability to process hits and store the processed AE digitized data must exceed the rate at which AE hits will be generated in the examination in order to record valid AE data.

7.8.3 The electronic circuitry shall be stable within ± 1 dB in the temperature range 4° to 49°C [40° to 120°F] (Based on manufacturer specifications).

7.8.4 The electronic circuit threshold shall be accurate within ± 1 dB (Based on manufacturer specifications).

8. Calibration, System Performance Verification, Verification of Normal Sensor Response, and System Electronic Noise Characterization

8.1 Calibration of AE sensors, preamplifiers, acquisition system and AE electronic waveform generator (AE simulator, used for locally checking the performance of an AE system) should be carried out in accordance with the equipment manufacturer's specifications and requirements. For additional information see X1.9.

8.2 System performance verification must be conducted immediately before each AE examination. Performance verification uses a mechanical device (see 8.2.1 for the preferred technique for composite samples) to induce (with a fast rise time and short duration) displacement waves into the material under examination, at a specified distance (sufficient so that the preamplifier is not saturated by a very large signal) from each sensor. Induced displacement waves stimulate a sensor in a similar way as waves from real AE sources. Performance verifications verify performance of the entire system including the couplant.

8.2.1 (a) The preferred technique for conducting performance verifications is a pencil lead break (PLB). The lead should be broken (see Guide E976) on the material surface at a fixed distance of about 10 to 15 cm [4 to 6 in.] from each sensor. When the

composite is not of quasi-isotropic construction, care should be taken so that the signal propagation path from the PLB to the sensor encounters the same fiber lay-up for each sensor. ASTM Guide E976 specifies 2H, 0.3 mm [0.012 in.] (or 0.5 mm [0.020 in.] 0.3-mm [0.012-in.] (or 0.5-mm [0.020-in.] providing a larger signal); signal) diameter lead. The length of the lead should be 3 mm [0.12 in.]. Typically the peak amplitude of the signal from each sensor is recorded for three identical PLBs, and the results for each channel should have an average peak amplitude within ± 4 dB from the average for all the channels. If a channel fails this test, it should be repeated after re-coupling the sensor for that channel, since improper coupling is a common problem. If the system still does not meet the performance requirements, the operator must determine the cause of the deficiency and take corrective action prior to the start of an examination. (b) In addition, a pencil lead should be broken in contact with the test sample surface at a location(s) such that the pulse generated leads to an AE hit at all the sensors intended for use in the application. The peak amplitudes from the signals from each sensor for three identical PLBs should be recorded along with the location of the PLB to provide data that provides a measure of attenuation of the wave propagation in the sample. When multiple samples are to be tested that are nominally the same, this attenuation data can be used to identify samples with better or worse attenuation than the average. Such data may be of use in the evaluation of differences in the AE generated in different test samples that are nominally the same. It also will provide a database for comparing relative signal strengths from a repeat set of PLBs after the AE examination.

8.2.2 An additional step may be useful in certain situations (for example when the sensors are covered with insulation after they are installed or when it is not safe to do the performance verifications during an AE test). This step consists of first following the description in 8.2.1. Then immediately conducting a performance verification by the use of an Auto Sensor Test (AST), where a pulse is applied successively to each sensor (which operates as a transducer or ultrasonic pulser) and the signals (typically the peak amplitude) from each of the adjacent sensors are collected. These results then provide a database that subsequent AST test results can be compared to when such tests are done at intermediate times during the AE examination and after the AE examination. This procedure also provides a database on the repeatability of wave propagation between the sensors for different test samples that are nominally the same.

8.3 Post system performance verification (by either or a combination of the techniques in 8.2.1 (b) and 8.2.2), selected so that a direct comparison can be made with the pretest results) is also to be completed immediately after the examination (when the test sample does not fail during the test) in order to verify that there were no significant changes in sensor coupling or system performance for each sensor and channel during the examination. However, in composites a variety of micro-damage or other test-induced damage can affect the post examination results due to changes in signal propagation characteristics. These changes may be observed and characterized by changes in the PLB or AST results.

8.3.1 If the post examination performance verification or any intermediate performance verification result shows that the system performance changed significantly (a loss of peak amplitude of more than 4 dB for any channel during the examination) the operator must note this in the report and determine if the system overall performance was still adequate. If not, then either the data analysis must be adjusted to account for the current system performance, or the test repeated with appropriate modifications (for example, if attenuation has increased significantly, then more sensors may be added to maintain sensitivity) to ensure valid results.

NOTE 1—It is not possible to repeat the AE generation from a virgin loading (that generates the characteristic damage state) of a composite sample during a subsequent retest.

NOTE 2—A repeated test must go to a higher load at least 10% above the first loading.

8.4 It is important to have a “reference geometry” for use in quickly verifying the performance of sensors suspected to be damaged. This can be done using a typical thickness quasi-isotropic composite plate (say 1 by 1 m (36 by 36 in.), to reduce edge reflections) upon which each sensor can be placed at a fixed location and subjected to the waves from a PLB at a fixed location. Comparing the PLB peak signal amplitude (and possibly the signal shape when waveform recording is being used) with previous data for that sensor (under the same conditions) may be used to identify faulty or non-performing sensors.

8.5 Characterization of system extraneous electronic noise is recommended by the following: (i) in a “quiet” environment away from significant electromagnetic noise sources (for example welding or operating overhead cranes; but not requiring a Faraday box or room) and mechanical noise sources, characterize the RMS (or equivalent ASL) noise level for each sensor/channel when each sensor is wrapped in foam (to eliminate any airborne noise) and not coupled to any solid; and (ii) in the same sensor environment determine the minimum threshold for each sensor/channel before consistent triggering on background electronic noise occurs. A typical value to define the minimum threshold would be a total of less than 10 hits per channel for a 15 minute time period. If there is more than a 3 dB difference in the noise level or the minimum threshold from the average of all channels, the faulty channel/channel/sensor should be repaired.

8.6 Routine electronic evaluations must be performed any time there is concern about signal processor performance. An AE electronic waveform generator or simulator should be used in making such evaluations. Each signal processor channel must respond with peak amplitude reading within ± 2 dB of the electronic waveform generator output.

9. Development of an AE Examination Plan

The AE examination plan includes the AE examination preparation. The examination plan is called out by the appropriate structural test plan for the component/structure to be examined.

9.1 Number of Sensors, Spacing of Sensors, and Locations of Sensors:

9.1.1 When determination of where AE sources originate is the primary goal, the number of sensors and their placement are determined differently depending on the AE technique used. If first-hit analysis is being used with resonant sensors, the maximum size of the regions to which it is desired to localize where the AE sources originated is approximately the total sample area being monitored divided by the number of sensors being used. If wideband sensors and wideband-based AE technology is being used, then the number of sensors is set by the discussion in 9.1.2.

9.1.2 When the primary goal is to effectively use AE to monitor the whole or a large part of a composite article, the number of sensors and their locations are best determined by attenuation measurements (with the selected sensor and selected electronic filters) on the composite article or on a test sample with the same materials, thickness and fiber lay-up. The attenuation measurements combined with the expected amplitudes of the AE sources of interest and the planned threshold (above the electronic or other background noise levels) determines how far apart the sensors can be located so that sources of interest do not have signals below the AE system threshold. Sensor spacing is normally decreased in the directions having higher attenuation (for example, in propagation directions perpendicular to a large percentage of the fibers). When basing the expected signal amplitudes from a database from small (25 mm [1 in.] wide) tensile or bending laboratory samples, the expected peak amplitudes should be reduced by about 10 to 12 dB to account for reinforcement of signal amplitude from edge reflections in small tab-type samples. For additional information see X1.10.

9.1.2.1 The desired method to characterize attenuation is the use of PLBs on the test sample edges. These PLBs with the axis of the pencil parallel to the plate surface should be done both on the test sample edge near the top or bottom surface and very near the mid-plane of the edge. The use of these two locations generates the full range of signal frequency (modal) dominance to be expected during testing. For additional information see X1.11. One sensor should be located very close to the PLB location (approximately within 6 mm [0.25 in.]) so that the attenuation information includes the near-field geometric attenuation. In this case, because a PLB is very close to the sensor, care must be taken that the AE signal from the nearest sensor (relative to the pencil lead break position) does not saturate the AE preamplifier. For additional information see X1.12. A series of additional sensors at several distances (up to or beyond the expected sensor spacing) from the source provide data (typically peak amplitude) to determine the loss of amplitude with increasing distance of propagation. To provide a true measure of attenuation for large test items, when a test sample of the same thickness and fiber layup (rather than the actual test article) is used for these wave propagation studies, the test sample should be of sufficient size sample (transverse dimensions should be at least two times the maximum propagation distance to be characterized) so that edge reflections do not significantly reinforce the direct path signals. Also, if the material is not quasi-isotropic, the propagation directions should include at a minimum the directions with the maximum and minimum in-plane and bending stiffness. In the case of a layup with large differences in the number of fibers in different directions, the attenuation measurements should also be made at different angles relative to the direction of the PLB force. In such cases modeling has shown there are both preferred propagation directions with less attenuation and non-preferred directions with higher attenuation.⁷

9.1.3 When the primary goal is a comparison between the damage accumulations in virgin samples as a function of increasing stress level for different designs (material components and/or fiber lay-up) of the same item for well designed composite items (having relatively uniform stress fields without regions with stress concentrations), a single AE sensor typically is sufficient along with RMS (typically both averaging time and time-driven interval of 200 to 300 ms) (or its equivalent ASL) measurements of the AE to characterize the accumulation of the characteristic damage state as a function of applied load. The high hit rates may preclude the use of the measurement of standard hit features. If the hit rate is not too high then, the RMS data can be supplemented by the standard hit features. If the test sample does not meet the requirement of stress uniformity, then the technique for selection of the number and placement of sensors should follow 9.1.2. The measurement technique for the generated AE would remain the same for each channel. This AE data for different designs may demonstrate optimal designs (material components and/or fiber lay-ups) having the least accumulation of damage up to a given test level (or design load level).

9.1.4 For test articles with known stress concentrations, the AE test plan should emphasize placement of sensors in those regions. In other regions, a sufficient sensor density should be used to monitor for possible unknown flaws, or stress concentrations, or both.

9.1.5 Specific information about the model identification of the sensors (model designation, whether resonant, and the resonant frequency or wideband) to be installed on the structure and the sensor installation techniques (coupling and attachment) and the materials used for the sensor installation should be specified.

9.2 The test plan should include the planned settings of the preamplifier gains and their filter range.

9.3 The AE measurement system setup for proper data acquisition for the specific structural geometry and materials must be specified. This information includes parameters such as the threshold (and system gain prior to the signal reaching the threshold circuitry), filter range and other parameters that depend on the particular AE system. In addition, the choices of the test parameters (for example, load, pressure, test temperature, etc.) to be recorded by the AE system during the test should be specified.

9.4 A suitable loading profile for AE testing of composites may be relatively simple or it can be complicated, consisting of many load cases in tension, compression, bending, multi-axial loading, and it may include environmental effects (not to induce loads)

⁷ "Acoustic Emission Signals versus Propagation Direction for Hybrid Composite Layup with Large Stiffness Differences versus Direction," Marvin A. Hamstad and Markus G. R. Sause, 31st Conference of the European Working Group on Acoustic Emission (EWGAE), Paper We.1.A.1, Dresden, Germany, 2014.

such as high/low test temperatures, vacuum, etc. For additional information see X1.13. The specific loading recommendations are described here. For additional information see X1.14.

9.4.1 Since polymer matrices are normally viscoelastic at typical test temperatures, ramp portions (increasing and decreasing) of the loading/unloading schedule should have controlled rates, and hold times at load as well as rest times at zero or near zero load should be specific and uniform in length or match each other. The method used to control the loading/unloading rate should be specified.

9.4.2 At the beginning of the examination, there should be an initial low level loading in the range of 5 % to 10 % of the target maximum load (Note that this is not shown in Figs. 2-5). This loading is done to verify the functional performance of every part of the entire system including test controls, loading paths and instrumentation. This low-level load also helps verify the initiation of the load path. If this is the virgin loading of the test article, then AE will typically be generated from the start of the formation of the characteristic damage state. After the specified initial low level loading verification, the AE examination proceeds by increased stressing of the structure.

9.4.3 A common loading profile that is attractive, particularly for proof testing, is a load-hold-unload-rest-reload test cycle as illustrated in Fig. 2. The primary AE monitoring in this case is during the second loading (used to obtain the FR), the second hold and the second unload. The initial loading-holding-unloading portion serves to normalize the sample prior to the primary AE monitoring. A modification of this profile for quality control testing or testing to optimize materials and/or fabrication parameters is to terminate the test after the first unloading, and to focus the AE monitoring on the first loading and first hold.

9.4.4 Another loading profile is shown in Fig. 3 (Note that the magnitude of the steps may be adjusted to fit particular cases). This loading sequence is more time consuming due to the repeated unloading. This loading sequence is valuable due to: (i) its elimination of most of the AE signals from the formation of the characteristic damage state during each reloading up to near the previous maximum load; (ii) its enabling evaluation of the Felicity ratio for each successive loading; and (iii) its enabling of evaluation of the load-hold AE at successively higher stresses and iv) its providing the test manager with AE-based feedback on the state of the composite such that decisions to continue or stop loading can be made without generation of significant additional damage or catastrophic failure occurring.

9.4.5 A sequence of steps of load and then a hold as illustrated in Fig. 4 provides an alternate loading sequence (Note that the magnitude of the steps may be adjusted to fit particular cases). This sequence may be dictated by other considerations in a composite structural test. In this case it is better to use longer hold times so as to allow more relevant AE monitoring when the characteristic damage state (virgin loading of the test article) is not being formed. This profile also provides the test manager with AE-based feedback (from the hold portions) on the state of the composite such that decisions to continue or stop can be made without generation of significant additional damage or catastrophic failure occurring.

9.4.6 Another sequence of load steps, holds and partial unloads is shown in Fig. 5 (Note that the magnitude of the steps may be adjusted to fit particular cases). This sequence, while not as desirable (lacks sufficient unloads-unloads, such as shown in Fig. 1 and Fig. 2, to fully activate the FR) it-FR), has the advantage of reducing the total test time.

9.5 Since many factors influence the nature and amount of AE in composite materials (fiber materials (includes fiber weaving and number of “ends”), matrix material, fiber volume, general internal macrostructure such as laminate lay-up, time between load cycles, loading rate, cure cycle, sample volume, subsequent loading cycles, porosity or void content, moisture content, history of load and temperature and test temperature), an AE characterization evaluation for a trial sample or preferably several trial samples may be needed to finalize details associated with the examination plan to determine the following:

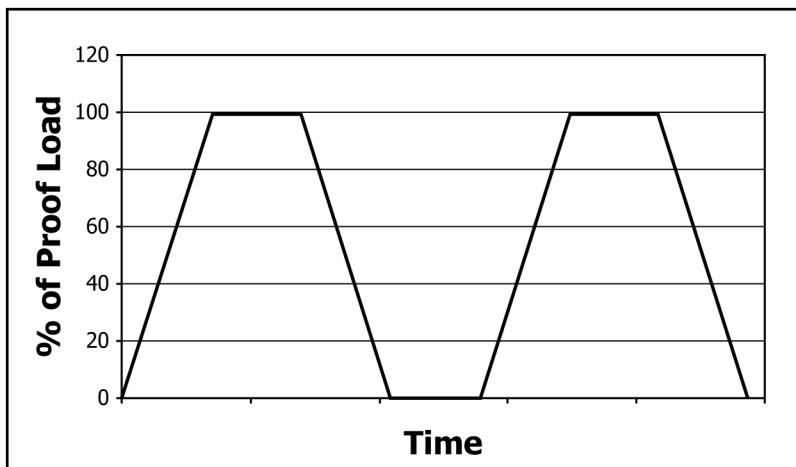

FIG. 2 Example of proof loading with holds and reload. All ramps and holds of equal duration.

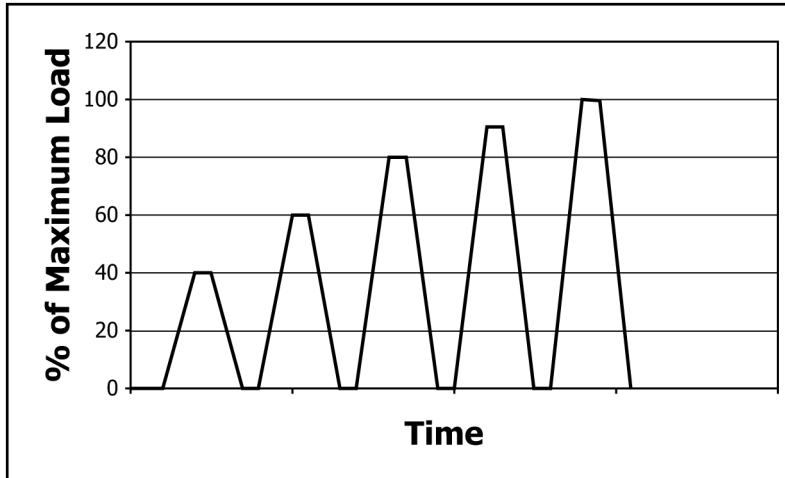

FIG. 3 Sequence of loading, hold and complete unloading. All ramps at equal rates and holds of equal duration.

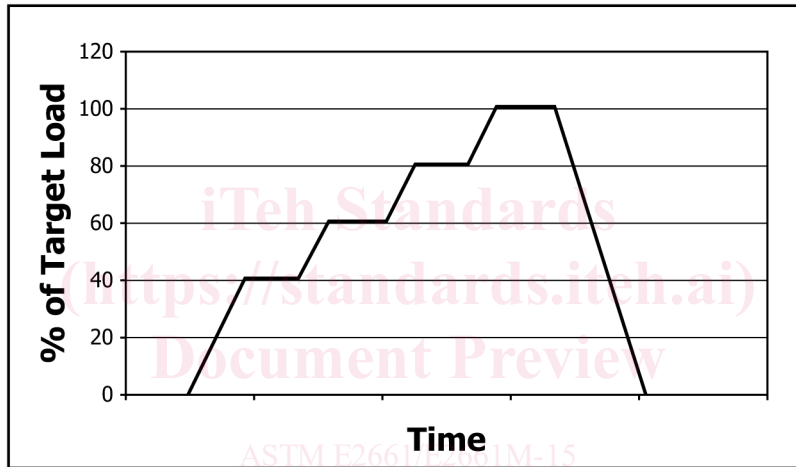

FIG. 4 Example of loading sequence in steps toward the target load. All ramps at equal rates and holds of equal duration.

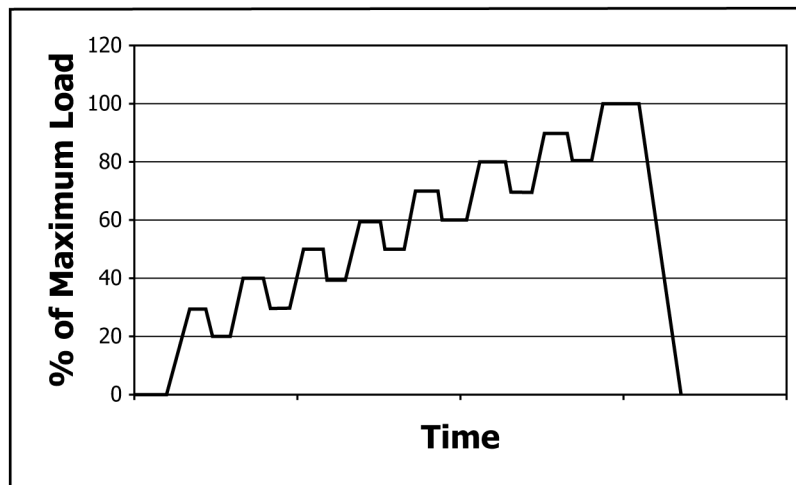

FIG. 5 Sequence of loading, hold and partial unloading. All ramps at equal rates and holds of equal duration.

9.5.1 Characteristics of AE wave propagation from real sources such as wave velocities (typically the velocity of the first arrival of the signal (hit)), attenuation and directional variations of these properties in the composite material. This information is used with other data to determine the final sensor spacing and sensor locations.

9.5.2 Characteristics of AE signals from the composite sample during loadings so as to enable distinguishing extraneous AE from AE signals of interest.

9.5.3 Characterization of typical AE amplitudes and AE event rates to provide guidance for the settings of AE system test parameters such as gains, thresholds and sensor spacing, as well as determination of any required modifications to the loading profile (for example the loading rate).

9.5.4 Development of appropriate acceptance/rejection criteria, when AE data is used in this role. Typically this AE application requires multiple “acceptable” and “unacceptable” test samples to establish the empirical criteria.

9.5.5 An evaluation of test environmental effects such as temperature, humidity and background noise, etc. should be specified in the test plan. Some typical sources of background extraneous noises are test fixturing, test grips, operating overhead cranes, hydraulic servo-valves, etc.

9.5.5.1 Specifically for background noise the following should be done. In the actual test environment with the sensors coupled to the test item the same two noise items specified in 8.5 should be measured for each channel. Comparing this data with that from the testing in section 8.5 can be used to identify and then correct any sensor/channel not consistent with average values for the actual test environment. For additional information see X1.15.

9.5.5.2 Specifically for humidity, due to the nature of the anticipated testing (not always well controlled laboratories) the control of the moisture content of test samples is not generally possible. If different test samples are expected to have significant changes in moisture content, then a series of tests with different moisture content is recommended to determine the effect of this variable on AE behavior.

9.6 Test samples should be identified based on sample type, sample condition, manufacturing characteristics, loading parameters, etc.

9.7 The AE data to be observed real time during the AE examination should be specified. The following is recommended.

9.7.1 Graph of total first hits (or counts from first hits) in each channel versus time and/or load as appropriate for the loading profile.

9.7.2 Graph of total hits (or total counts) from all channels versus time and/or load as appropriate for the loading profile.

9.7.3 Graph of total first-hit energy in each channel versus time and/or load as appropriate for the loading profile.

9.7.4 Graph of total-hit energy from all channels versus time and/or load as appropriate for the loading profile.

9.7.5 The graphs of 9.7.1 through 9.7.4 can be conveniently viewed as three dimensional plots of AE versus load or time versus channel number.

9.7.6 In addition three dimensional plots of RMS (or its equivalent ASL) versus load or time versus channel are also useful to monitor any changes in certain background noise levels during an examination.

9.8 AE-based criteria to determine when a premature halt to loading (based on the AE data) is required.

9.8.1 Emergency test stop criteria should be established if AE monitoring is required as a “go/no-go” decision factor relative to continued loading. This role for an AE examination requires real-time AE data review during loading (FR) or during load holds (see 10.11). The purpose of this real-time evaluation is to determine the significance of the AE data relative to the component’s continued structural integrity under additional loading. The emergency stop criteria will determine if the examination should be terminated to prevent any additional damage. If the review reveals that the AE data has met the criteria, then, the loading needs to be immediately halted and followed by appropriate unloading.

9.9 The AE examination plan should be reviewed and approved by the appropriate authority and coordinated with those responsible for structural test engineering. It is desirable that those planning AE examinations of composites should be trained or experienced in both AE technology and testing of composite materials. Also they should possess knowledge of mechanical behavior of composite materials and their failure mechanisms.

10. AE Examination

10.1 Place the test sample in the load frame or load the article in-place. Insure that extraneous noise is kept to a minimum by isolating mechanical and electrical noise sources. For additional information see X1.16.

10.2 Install AE sensors at the planned locations with approved attachment techniques and materials.

10.3 Route cables and preamplifiers and secure them in place so they will not cause frictional AE during the test.

10.4 Set up the AE equipment in a safe place or a protective area as required.

10.5 Verify or adjust the planned data acquisition parameter settings for the best results in detecting acoustic emission of interest and filtering extraneous noises.

10.5.1 Check the ASL or RMS level for each channel. Record the values and compare with the values found in a “quiet” test environment (see 8.5). Make corrections if necessary. Also check the minimum threshold that can be set in each channel to identify any noisy channels (see 8.5). Record the minimum thresholds and compare with the values found in a “quiet” test environment (see 8.5). Make corrections as necessary. If unavoidable extraneous noise sources in the test environment require the AE threshold