



Designation: **F2789 – 10** ~~F2789 – 10~~ (Reapproved 2015)

Standard Guide for Mechanical and Functional Characterization of Nucleus Devices¹

This standard is issued under the fixed designation F2789; the number immediately following the designation indicates the year of original adoption or, in the case of revision, the year of last revision. A number in parentheses indicates the year of last reapproval. A superscript epsilon (ϵ) indicates an editorial change since the last revision or reapproval.

1. Scope

1.1 This guide describes various forms of nucleus replacement and nucleus augmentation devices. It further outlines the types of testing that are recommended in evaluating the performance of these devices.

1.2 Biocompatibility of the materials used in a nucleus replacement device is not addressed in this guide. However, users should investigate the biocompatibility of their device separately (see X1.1).

1.3 While it is understood that expulsion and endplate fractures represent documented clinical failures, this guide does not specifically address them, although some of the factors that relate to expulsion have been included (see X1.3).

1.4 Multiple tests are described in this guide; however, the user need not use them all. It is the responsibility of the user of this guide to determine which tests are appropriate for the devices being tested and their potential application. Some tests may not be applicable for all types of devices. Moreover, some nucleus devices may not be stable in all test configurations. However, this does not necessarily mean that the test methods described are unsuitable.

1.5 The science of nucleus device design is still very young and includes technology that is changing more quickly than this guide can be modified. Therefore, the user must carefully consider the applicability of this guide to the user's particular device; the guide may not be appropriate for every device. For example, at the time of publication, this guide does not address the nucleus replacement and nucleus augmentation devices that are designed to be partially or completely resorbable in the body. However, some of the test recommended in this guide may be applicable to evaluate such devices. It has not been demonstrated that mechanical failure of nucleus devices is related to adverse clinical results. Therefore this standard should be used with care in evaluating proposed nucleus devices.

1.6 This guide is not intended to be a performance standard. It is the responsibility of the user of this guide to characterize the safety and effectiveness of the nucleus device under evaluation.

1.7 The values stated in SI units are to be regarded as standard. No other units of measurement are included in this standard. Angular measurements may be reported in either degrees or radians.

1.8 *This standard does not purport to address all of the safety concerns, if any, associated with its use. It is the responsibility of the user of this standard to establish appropriate safety and health practices and determine the applicability of regulatory limitations prior to use.*

2. Referenced Documents

2.1 ASTM Standards:²

[D2990 Test Methods for Tensile, Compressive, and Flexural Creep and Creep-Rupture of Plastics](#)

[D6204 Test Method for Rubber—Measurement of Unvulcanized Rheological Properties Using Rotorless Shear Rheometers](#)

[E6 Terminology Relating to Methods of Mechanical Testing](#)

[E111 Test Method for Young's Modulus, Tangent Modulus, and Chord Modulus](#)

[E132 Test Method for Poisson's Ratio at Room Temperature](#)

[E328 Test Methods for Stress Relaxation for Materials and Structures](#)

¹ This test method is under the jurisdiction of ASTM Committee F04 on Medical and Surgical Materials and Devices and is the direct responsibility of Subcommittee F04.25 on Spinal Devices.

Current edition approved ~~June 1, 2010~~ May 1, 2015. Published ~~July 2010~~ July 2015. Originally approved in 2010. Last previous edition approved in 2010 as F2789 – 10. DOI: ~~10.1520/F2789-10-10~~ 10.1520/F2789-10R15.

² For referenced ASTM standards, visit the ASTM website, www.astm.org, or contact ASTM Customer Service at service@astm.org. For *Annual Book of ASTM Standards* volume information, refer to the standard's Document Summary page on the ASTM website.

- E1823 Terminology Relating to Fatigue and Fracture Testing
 - F561 Practice for Retrieval and Analysis of Medical Devices, and Associated Tissues and Fluids
 - F1582 Terminology Relating to Spinal Implants
 - F1714 Guide for Gravimetric Wear Assessment of Prosthetic Hip Designs in Simulator Devices
 - F1877 Practice for Characterization of Particles
 - F1980 Guide for Accelerated Aging of Sterile Barrier Systems for Medical Devices
 - F2267 Test Method for Measuring Load Induced Subsidence of Intervertebral Body Fusion Device Under Static Axial Compression
 - F2346 Test Methods for Static and Dynamic Characterization of Spinal Artificial Discs
 - F2423 Guide for Functional, Kinematic, and Wear Assessment of Total Disc Prostheses
- 2.2 *Other Standards:*³
- ISO 10993 Biological Evaluation of Medical Devices: Parts 1–20
 - ISO 18192–1 Implants for Surgery—Wear of Total Intervertebral Spinal Disc Prostheses

3. Terminology

3.1 For definition of terms, refer to Terminologies E6, E1823, and F1582.

3.2 *Definitions:*

3.2.1 *coordinate system/axes, n*—Three orthogonal axes are defined by Terminology F1582. The center of the coordinate system is located at the geometric center of the native disc. Because of design intent, or procedural limitations, the device might not be implanted at the center of the native disc; therefore, the geometric center of the disc might not be the geometric center of the device. For uniformity in comparison between devices, it is important that the origin be placed with respect to the disc, not the device. This is done so that all loading is consistently applied and measurement made with respect to the anatomy of the spine, and not with respect to the device. The *XY* plane bisects the sagittal plane between superior and inferior surfaces that are intended to simulate the adjacent vertebral endplates. The positive *X* axis is to be directed anteriorly. The positive *Z* axis is to be directed superiorly. Shear components of loading are defined to be the components parallel to the *XY* plane. The compressive axial force is defined to be the component in either the positive or negative *Z* direction depending on the test frame set-up. Torsional load is defined as the component of moment about the *Z* axis.

3.2.2 *energy absorption, n*—The work or energy (in joules) that a material can store, temporarily or permanently, after a given stress is applied and then released.

3.2.3 *expulsion, n*—a condition during testing when the device or a component of the device becomes fully displaced or dislodged from its implanted position (that is, in the direction of shear) through a surrogate annulus, or enclosure used to simulate an annular boundary. Expulsion may be considered a specific type of migration and for the purposes of this standard is only useful when the testing is being conducted within a surrogate annulus or enclosure.

3.2.4 *extrusion, n*—a condition during testing when a portion of a device displaces through a surrounding membrane or enclosure but does not separate from the rest of the device. Extrusion may be considered a specific type of migration and for the purposes of this standard is only useful when the testing is being conducted within a surrogate annulus or enclosure.

3.2.5 *fatigue life, n*—The number of cycles, *N*, that the nucleus device can sustain at a particular load or moment before functional or mechanical failure occurs.

3.2.6 *functional failure, n*—A failure that renders the nucleus device ineffective or unable to resist load or function as predetermined within desired parameters (for example, permanent deformation, dissociation, dehydration, expulsion, extrusion or fracture), or both.

³ Available from American National Standards Institute (ANSI), 25 W. 43rd St., 4th Floor, New York, NY 10036, <http://www.ansi.org>.

3.2.6.1 *Discussion*—

Functional failure may or may not be correlated with clinical failure.

3.2.7 *hysteresis, n*—The resultant loop on a force displacement plot that is created from a mechanical test performed on a viscoelastic material. The area inside the loop can be used to determine the energy absorption.

3.2.8 *mechanical failure, n*—A failure associated with the onset of a defect in the material (for example, a fatigue fracture, a static fracture, or surface wear).

3.2.8.1 *Discussion*—

A mechanical failure can occur without there being a functional failure.

3.2.9 *migration, n*—A condition during testing when a device displaces from its original position during testing. Migration may or may not be considered a specific type of functional failure. The user is expected to define their criteria for acceptable levels of migration and provide rationale for those criteria. See also definitions for expulsion, extrusion, and subsidence.

3.2.10 *nucleus device, n*—A generic term that refers to all types of devices intended to replace or augment the nucleus pulposus in the intervertebral disc. Adjectives can be added to the term “nucleus device” to more thoroughly describe the device’s intended function. Terms 3.2.10.1 through 3.2.10.9 will be used to address specific types of nucleus devices throughout the rest of this guide. These terms may not apply to all nucleus devices and some combinations of terms may be applicable to certain devices. However, this term should not be used interchangeably with annular repair device.

3.2.10.1 *complete nucleus replacement device, n*—A nucleus device that is designed to replace most or all ($\geq 50\%$ by volume) of the nucleus pulposus of the intervertebral disc.

3.2.10.2 *partial nucleus replacement device, n*—A nucleus device that is designed to replace some ($< 50\%$ by volume) of the nucleus pulposus of the intervertebral disc.

3.2.10.3 *nucleus augmentation device, n*—A nucleus device that is designed to supplement or augment, but not replace, the existing nucleus pulposus in the intervertebral disc.

3.2.10.4 *encapsulated nucleus device, n*—A nucleus device that includes an outer jacket, bag, or a similar casing, which in turn interfaces directly with the *in vivo* environment.

3.2.10.5 *open nucleus device, n*—A nucleus device that is not encased. The material interfaces directly with the *in vivo* environment.

3.2.10.6 *in situ formed nucleus device, n*—A nucleus device that is introduced into the disc space without a predetermined geometry. This may include injectable, in situ curing or polymerizing nucleus devices.

3.2.10.7 *preformed nucleus device, n*—A nucleus device that is introduced into the disc space already in a predetermined, but not necessarily final, geometry with all chemical processes completed prior to insertion.

3.2.10.8 *non-hydrated nucleus device, n*—A nucleus device that does not require water to be present to achieve its intended purposes.

3.2.10.9 *hydrated nucleus device, n*—A nucleus device that requires water to be present to achieve its intended purposes.

3.2.11 *Range of Motion (ROM), n*—The difference between the minimum and maximum displacement or angular displacement of the nucleus device that occurs during a test. This parameter may be useful when a surrogate annulus is used for testing.

3.2.12 *secant stiffness, n*—For a given applied load or applied displacement: $[(\text{maximum load}) - (\text{minimum load})]/[(\text{maximum displacement}) - (\text{minimum displacement})]$.

3.2.13 *stiffness, n*—The slope of the linear portion of the load-displacement curve or of the moment-angular displacement curve at a segment within normal physiologic parameters. If there is no linear portion, then stiffness may be estimated using other standard methods such as those found in Test Method E111 (chord or tangential stiffness, or both) within normal physiologic parameters.

3.2.14 *subsidence, n*—Settling or migration of the device into the inferior or superior interfaces adjacent to the device. Subsidence may be considered a specific type of migration and, for the purposes of this standard, is only useful when the mating endplates, fixtures or surrogate annulus have a modulus that allows subsidence to occur.

4. Summary of Test Method

4.1 The tests for characterizing the performance of nucleus devices can include one or more of the following: static and dynamic axial compression, axial torsion, and shear tests, functional range of motion, subsidence, mechanical behavior change due to aging, swelling pressure, and viscoelastic testing. Table 1 summarizes these tests with reference to sections where they are described in more detail. Additionally, Table 1 also lists additional reference documents that may be applicable to each particular test.

4.2 Some tests may not be applicable for all types of nucleus devices.

4.3 Where appropriate, a surrogate annulus may be used to further characterize the nucleus device.

4.4 All tests shall be performed on the nucleus device in the same shape, size, and condition as it would be used clinically unless adequately justified (that is, if gamma radiation is to be used to sterilize the device, or the device is meant to function in a hydrated state, then all tests should be performed on gamma-irradiated or hydrated parts or a justification shall be made).

4.5 Nucleus devices shall be tested statically to failure and also tested cyclically to estimate the maximum run out load or moment at 10×10^6 cycles. Depending on the test and intended use, the devices can be tested in force control or in position control, but in either case, the control mode should be justified.

5. Significance and Use

5.1 Nucleus devices are generally designed to augment the mechanical function of native degenerated nucleus material or to replace tissue that has been removed during a surgical procedure. This guide outlines methods for evaluating many different types



TABLE 1 Summary of Test Methods

Test Grouping	Test Type	Boundary and Sample Conditions	Section of this Standard	Applicable Standard or Reference
Static	Axial Compression	As Manufactured	7.2	Test Methods F2346
	Axial Torsion	With Surrogate Annulus	7.1 and 7.2	
	Shear	Simulated Aged	7.2 and 7.7	
	Bending	With Surrogate Annulus and Simulated Aged	7.1, 7.2, and 7.7	
Dynamic (Fatigue and Wear)	Axial Compression	As Manufactured	7.3	Test Methods F2346, Guide F2423 and ISO 18192-1
	Axial Torsion	With Surrogate Annulus	7.1 and 7.3	
	Shear	Simulated Aged	7.3 and 7.7	
	Bending	With Surrogate Annulus and Simulated Aged	7.1, 7.3, and 7.7	
Functional Testing	Functional Range of Motion	As Manufactured	7.3.6	Wilke, 1998 (1) Catellani, 1989 (2) Test Methods D2990 Test Method F2267
		(After simulated aging and with surrogate annulus where applicable)	(7.1 and 7.7 where applicable)	
	Lifting Force		7.4	
			(7.1 and 7.7 where applicable)	
	Viscoelastic Testing		7.5	
			(7.1 and 7.7 where applicable)	
Subsidence		7.6 (7.1 and 7.7 where applicable)		

of devices. Comparisons between devices must be made cautiously and with careful analysis, taking into account the effects that design and functional differences can have on the testing configurations and overall performance, and the possibility that mechanical failure may not be related to clinical failure and inversely, that mechanical success may not be related to clinical success.

5.2 These tests are conducted *in vitro* to allow for analysis of the mechanical performance of the nucleus device under specific testing modalities. The loads applied may differ from the complex loading seen *in vivo*, and therefore the results from these tests may not directly predict *in vivo* performance.

5.3 These tests are used to quantify the static and dynamic properties and performance of different implant designs. The mechanical tests are conducted *in vitro* using simplified loads and moments. Fatigue testing in a simulated body fluid or saline may have fretting, aging, corroding, or lubricating effects on the device and thereby affect the relative performance of tested devices. Hence, the test environment and the effect of that environment, whether a simulated body fluid, normal saline bath (9 g NaCl per 1000 mL H₂O), or dry, is an important characteristic of the test and must be reported accurately.

5.4 Dynamic testing methods should be designed to answer the following questions, including but not limited to: Does the device still function as intended after cycling? Does it retain adequate performance characteristics (for example, mechanical and kinematic properties such as ROM)? Did the device wear or degrade? If there is evidence of wear or degradation of the device, it should be identified and quantified with reasonable methods generally available. The user shall distinguish between particulates generated by the device and particulates generated by the test model and fixtures if technically feasible.

6. Sampling and Test Specimens

6.1 It is suggested that a minimum sample size of five be used for each form of testing described in Section 7. However, note that, as for any experimental comparison, the total number of needed specimens will depend on the magnitude of the difference to be established, the repeatability of the results (standard deviation), and the level of statistical significance desired.

6.2 The test assemblies (that is, nucleus pulposus test samples in their tested configuration) shall be labeled so they can be traced, and shall be kept in a clean environment to avoid contamination. The test assembly can be disassembled to facilitate examination of surface conditions.

TEST METHODS

7. Procedure

7.1 Use of a Surrogate Annulus:

7.1.1 Since most nucleus devices are designed to work with an intact or partly intact annulus fibrosus, the use of a surrogate annulus to perform the tests below may be considered. This annulus can be modeled in the test set-up if applicable (see X1.2 for references that detail examples of lumbar test models). The use of a simulated annulus may be necessary to allow for testing of an open, *in situ* formed device and to test a nucleus device in load/moment control. However, it may not be necessary if the tests are performed in displacement/angle control.

7.1.2 If a surrogate annulus is used, it should be characterized without the nucleus replacement device present for comparison to available published *in vitro* data for the human annulus (for example, stiffness and radial bulge) (3, 4).⁴

⁴ The boldface numbers in parentheses refer to a list of references at the end of this standard.

7.1.3 For dynamic and fatigue testing, the fatigue life of the annulus shall be quantified. If it is determined that the surrogate annulus will not survive 10×10^6 cycles in a fatigue or wear test, a suggested replacement interval shall be determined. For example, if an annulus is found to survive 3×10^6 cycles, a replacement interval of 2.5×10^6 cycles may be chosen.

7.1.4 Where appropriate, the viscoelastic response of the surrogate annulus (for example, stress relaxation and creep) shall be quantified.

7.1.5 Where necessary (particularly in hydrated nucleus pulposus replacements), the surrogate annulus shall allow appropriate fluid availability to the nucleus pulposus replacement.

7.1.6 The surrogate annulus should be comprised of a material that is easily distinguishable from the device under test. Where the materials are similar, standard particle characterization techniques may not be adequate to effectively characterize particle size, shape or morphology to distinguish between the two materials.

7.2 Static Testing:

7.2.1 Axial compression, axial torsion, compression/shear, flexion/extension, lateral bending tests should be performed in either force/moment control or displacement/angle control.

7.2.2 Refer to Test Methods **F2346**, Guide **F2423**, and ISO 18192–1 for suggested load/moment and displacement/angle inputs.

7.2.3 The test set-up of the axial compression, axial torsion, and compression/shear test should follow the set-up and fixtures described in Test Methods **F2346**. Any necessary deviations should be noted (for example, if a surrogate annulus is used as shown in **X1.2**, a polyacetal test block may be unnecessary).

7.2.4 For viscoelastic or strain rate sensitive materials, the effect of loading rate should be considered and characterized. This might include testing at different strain rates or impact loading as compared to a typical static test, which might be performed at a rate of 1-25 mm/min. Elevated strain rates or impact rates should be justified.

7.3 Dynamic Testing:

7.3.1 Dynamic tests should be completed using methods defined in Test Methods **F2346**, Guide **F2423**, or ISO 18192–1, or combinations thereof, noting any necessary deviations.

7.3.2 Where possible, the nucleus pulposus replacement device shall be tested in combined flexion/extension, lateral bending, axial rotation and axial loading. The test setup for combinations of flexion/extension, lateral bending, axial rotation and axial loading should follow the guidelines described in Guide **F2423** or ISO 18192–1. All tests without a dynamic compression component should be completed with a static axial compressive preload. The preload or displacement (or angulation), or both, for each test should be justified.

7.3.3 Test Methods **F2346** states that the end of the test is defined as a functional failure or the attainment of 10×10^6 cycles. If a mechanical failure (for example, fatigue crack, surface wear) that is not a functional failure occurs, it should be reported in detail. However, the test should be continued until a functional failure or the attainment of 10×10^6 cycles occurs.

7.3.4 Testing should be performed in a physiologic solution if possible. The environment should be maintained at body temperature ($37 \pm 3^\circ\text{C}$), as many materials exhibit different properties at different temperatures.

7.3.5 If an analysis of wear or degradation products of the nucleus device is performed on the environmental solution, the user should be able to distinguish between particulates generated by the device and particulates generated by the surrogate annulus or fixtures, or both.

7.3.6 Kinematic and functional evaluation should be performed by examining and comparing the range of motion, stiffness, secant stiffness, or the hysteresis of the device, or combinations thereof, at the start and finish of the test. These evaluations can also be conducted at intermediate points as an option. Depending on the device, one or more of the metrics above may be determined to be useful for adequate characterization of the device **(1)**.

7.3.7 An analysis of wear or degradation should be done according to methods described in Practice **F561**, Guide **F1714**, and Practice **F1877**.

7.4 Lifting Force:

7.4.1 An assessment of axial lifting force exerted by a hydrated nucleus replacement device during the absorption process may be performed by placing the specimen between two discs in a rigid cage. Axial lifting force is performed on hydrated nucleus replacement devices by placing the specimen between two discs in a rigid cage. A force transducer placed in line with the cage can be used to measure the force exerted by the device when it is placed in contact with the chosen solution. A method developed by Catellani, et al. describes a test apparatus and procedure for quantifying lifting force **(2)**. A diagram of a suggested apparatus is provided as **Fig. 1**; further details regarding the apparatus and a procedure are provided as **7.4.1.1- 7.4.1.4** and **7.4.1.5**, respectively.

7.4.1.1 The objective of the test systems shown in **Fig. 1** is to determine the amount of water absorbed and the lifting force generated during the absorption process.

7.4.1.2 The frame is used for mounting the load cell and sample chamber, which consists of a stainless steel cage and a glass disc on which the sample sits. It also provides a controlled means by which to lower the sample chamber assembly into solution.

7.4.1.3 The steel cage assembly provides a rigid interface to the load cell such that, as the sample absorbs fluid, the force generated by the increasing volume of the sample is measured on the load cell.

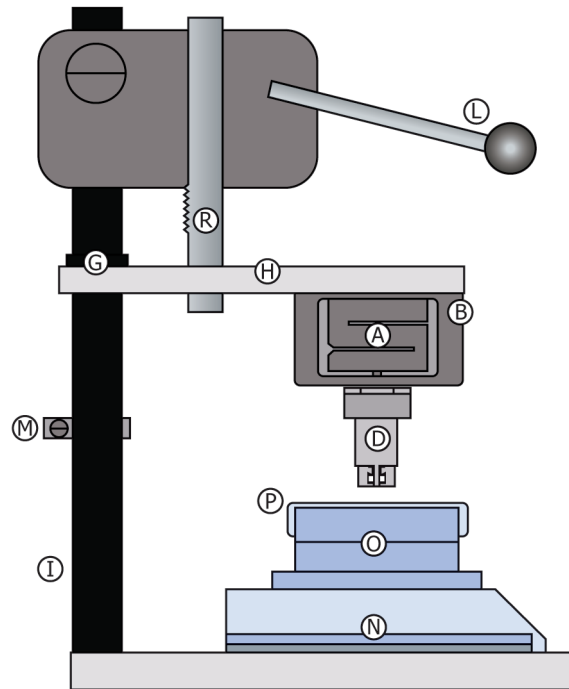

Disintegration Force-Water Uptake Measuring Apparatus
 A = extensimetric loading cell; B = metallic frame; D = steel cage;
 G = slide guide; H = steel arm; I = steel bar; L = controlling lever;
 R = master rack; M = lock; N = precision balance;
 O = glass container; P = plexiglas lid

FIG. 1 Disintegration Force-Water Uptake Measuring Apparatus (Ref (2))

7.4.1.4 The system utilizes a balance with a mounted water bath into which the sample is lowered. This scale measures the water loss from the bath due to sample fluid uptake.

7.4.1.5 Procedure:

(1) The sample is mounted into the sample chamber assembly (Fig. 1, D) and at a rate of approximately 1.0 mm/sec lowered into solution (that is, phosphate buffered saline (PBS)).

(2) As the sample absorbs fluid, the decrease in the mass of the fluid corresponds to the mass of fluid gained by the sample.

(3) As the sample expands, the lifting force generated by the device is recorded by the load cell.

(4) The test should be conducted until the sample, lifting force, and fluid absorption process reach steady state. Should another stopping point be selected, it should be justified by the user.

7.4.2 Swelling Test:

7.4.2.1 A swelling test can be performed by placing the nucleus device in a rigid chamber with a permeable plunger. The chamber is placed in a physiologic solution (solution formulation to be determined by the user based upon their device and intended use). By allowing the physiologic solution to diffuse in and out of the device, the device could change volume. As long as the plunger maintains a negligible load on the device, this change in volume is measured by the displacement of the plunger. The load shall be monitored throughout the duration of the swelling test and reported as a function of time.

7.4.2.2 Alternatively, Archimedes' Principle (buoyant forces) can be used to calculate the swelled volume by measuring the mass of device, and the mass of the device while suspended in the physiologic solution. The volume can be defined as:

$$V = \frac{m_0 - m_b}{\rho} \quad (1)$$

where:

- V = volume of the device,
- m_0 = the mass of the device,
- m_b = the buoyant mass of the device (mass while suspended in water), and
- ρ = the density of the solution.

7.5 Viscoelastic Testing:

7.5.1 Viscoelastic testing can be done as either a creep/creep recovery test or as a stress-relaxation test.

7.5.2 Creep testing should follow the test methods described in Test Methods D2990 when applicable.