



Designation: **F2819 – 10 F2819 – 10 (Reapproved 2015)**

Standard Test Methods for Measurement of Straightness of Bar, Rod, Tubing and Wire to be used for Medical Devices¹

This standard is issued under the fixed designation F2819; the number immediately following the designation indicates the year of original adoption or, in the case of revision, the year of last revision. A number in parentheses indicates the year of last reapproval. A superscript epsilon (ϵ) indicates an editorial change since the last revision or reapproval.

1. Scope

1.1 This standard covers the various test methods to be used for measurement of straightness of bar, rod, tubing, and wire. These test methods apply primarily to bar, rod, tubing, and wire that are ordered in the straightened and cut-to-length condition. It also applies to small diameter tubing and wire that has been specially processed to roll off a spool in the straightened condition.

1.2 These test methods apply to straightness of round wire that has a diameter between 0.05 and 4.78 mm (0.002 and 0.188 in.). They also apply to flatness (camber) of flat-shaped wire or ribbon with a maximum dimension between 0.05 and 4.78 mm (0.002 and 0.188 in.). For flatness (camber) measurement, refer to Test Method **F2754/F2754M**.

NOTE 1—The current version of Test Method **F2754/F2754M** covers a different diameter range (0.0127 to 4.78 mm (0.0005 to 0.188 in.)) and does not include superelastic NiTi. These exceptions would not affect the camber measurement as conducted by Test Method **F2754/F2754M**.

1.3 These test methods apply to straightness of round tubing that has an outer diameter between 0.05 and 6.35 mm (0.002 and 0.25 in.).

1.4 These test methods apply to straightness of round rod that has a diameter between 4.78 and 6.35 mm (0.188 and 0.25 in.). It also applies to flatness (camber) of flat and shaped rod with a maximum dimension between 4.78 and 6.35 mm (0.188 and 0.25 in.). For measurement of flatness (camber), refer to Test Method **F2754/F2754M**.

NOTE 2—The current version of Test Method **F2754/F2754M** covers a different diameter range (0.0127 to 4.78 mm (0.0005 to 0.188 in.)) and does not include superelastic NiTi. These exceptions would not affect the camber measurement as conducted by Test Method **F2754/F2754M**.

1.5 These test methods apply to straightness of round bar that has a diameter between 6.35 and 101.6 mm (0.25 and 4 in.). It also applies to flatness (camber) of flat and shaped bar with a maximum dimension between 6.35 and 101.6 mm (0.25 and 4 in.). For measurement of flatness (camber), refer to Test Method **F2754/F2754M**.

NOTE 3—The current version of Test Method **F2754/F2754M** covers a different diameter range (0.0127 to 4.78 mm (0.0005 to 0.188 in.)) and does not include superelastic NiTi. These exceptions would not affect the camber measurement as conducted by Test Method **F2754/F2754M**.

1.6 These test methods apply to ferrous and non-ferrous alloys including linear-elastic or superelastic nitinol. Refer to Terminology **F2005** for more details on NiTi terminology.

1.7 The values stated in either SI units or inch-pound units are to be regarded separately as standard. The values stated in each system may not be exact equivalents; therefore, each system shall be used independently of the other. Combining values from the two systems may result in non-conformance with the standard.

1.8 *This standard does not purport to address all of the safety concerns, if any, associated with its use. It is the responsibility of the user of this standard to establish appropriate safety and health practices and determine the applicability of regulatory limitations prior to use.*

2. Referenced Documents

2.1 *ASTM Standards:*²

F2005 Terminology for Nickel-Titanium Shape Memory Alloys

F2754/F2754M Test Method for Measurement of Camber, Cast, Helix and Direction of Helix of Coiled Wire

¹ These test methods are under the jurisdiction of ASTM Committee **F04** on Medical and Surgical Materials and Devices and is the direct responsibility of Subcommittee **F04.15** on Material Test Methods.

Current edition approved Dec. 15, 2010; May 1, 2015. Published January 2011; July 2015. Originally approved in 2010. Last previous edition approved in 2010 as F2819 – 10. DOI: ~~10.1520/F2819-10~~.1520/F2819-10R15.

² For referenced ASTM standards, visit the ASTM website, www.astm.org, or contact ASTM Customer Service at service@astm.org. For *Annual Book of ASTM Standards* volume information, refer to the standard's Document Summary page on the ASTM website.

2.2 Other Standards:³

GGG-P-463 U.S. Federal Specification: Plate, Surface (Granite)

3. Terminology

3.1 Fig. 1 and Fig. 2 show the physical meaning of straightness. Fig. 3 shows the definition of wobble in a straight wire as it is being rotated.

3.2 Definitions of Terms Specific to This Standard:

3.2.1 *straightness*—Deviation of an axis or surface element from linearity over a unit length in the unloaded (force and moment free) condition. A perfectly straight condition is shown in Fig. 1. An unloaded condition is shown in Fig. 2.

3.2.2 *wobble*—Elliptical rotation observed in a small diameter wire or tube as it is being rotated around a central axis as is shown in Fig. 3.

4. Summary of Test Method

4.1 For bar, rod, tube, and wire, the deviation from the condition of resting flat on a smooth surface can be measured by using a quantitative or qualitative test method. Two quantitative and two qualitative methods are the gap and TIR (Total Indicator Readout) and inclined flat plate and finger roll tests, respectively

4.2 *Inclined Flat Plate Test (qualitative test method that can be made quantitative)*—A common method for measurement of straightness of wire or tubing with a diameter less than 4.78 mm (0.188 in.) is the inclined flat plate test. In this method, a sectioned piece of material is allowed to roll down an inclined table as is illustrated by Fig. 4 and Fig. 5. The material passes the test if it rolls freely down the table without stopping as is shown by Fig. 5.

4.3 *Finger-Roll Test (qualitative test method)*—A second common method for measurement of straightness that is used for wire and tubing with a diameter less than 0.25 mm (0.010 in.) is the finger-roll test. In this test, a cut length of wire or tubing is laid on a flat surface. A finger, pencil, pen, or plastic card is used to rotate the center of the sample back and forth on the flat surface. The opposite ends of the sample should rotate smoothly without wobble as is defined in 3.2.2 of these test methods.

4.4 *Gap Test (quantitative test method)*—A common quantitative method for measurement of straightness of wire with a diameter less than 4.78 mm (0.188 in.) is the gap test. It can also be used for rod with a diameter between 4.78 and 6.35 mm (0.188 and 0.25 in.), tubing with diameter 0.05 to 6.35 mm (0.0002 to 0.25 in.) or bar with a diameter between 6.35 to 101.7 mm (0.25 to 4 in.), the gap test can be used to measure straightness. The gap test can also be used for flat or shaped wire and ribbon. In this method, a thickness gauge equal to the gap must not fit between the rod, tubing, or bar and flat surface at any point along its length when rolled or rotated 360°. The gap defines the straightness of the rod, tubing, or bar.

4.5 *Total Indicator Readout (TIR) test (quantitative test method)*—In this method, a round rod with a diameter between 4.78 and 6.35 mm (0.188 and 0.25 in.) or round bar with a diameter between 6.35 to 101.7 mm (0.25 to 4 in.), is placed on two or more V-blocks. The test specimen is then rotated one revolution between two or more V-blocks that are a fixed distance (*d*) apart while measuring in the center with an indicator. Total Indicator Readout (TIR) in the test specimen is then calculated.

5. Significance and Use

5.1 *Significance*—With the birth of minimally invasive surgery in the 1960s, there has been a requirement for guide wires. The guide wires serve as the access line by which procedures like balloon angioplasty and stent placement are conducted. A guide wire

³ Available from IHS, 321 Inverness Drive South Englewood, CO 80112, <http://www.global.ihs.com>.

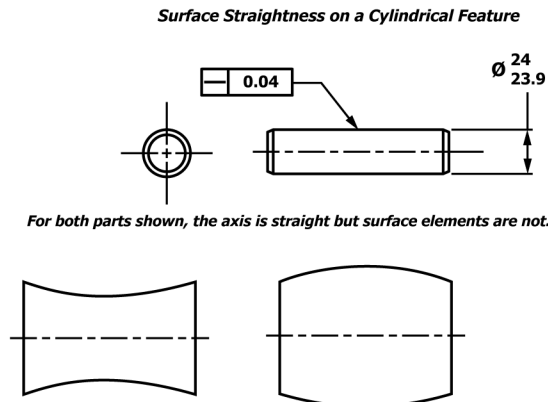

FIG. 1 Definition of a “Straight” Condition

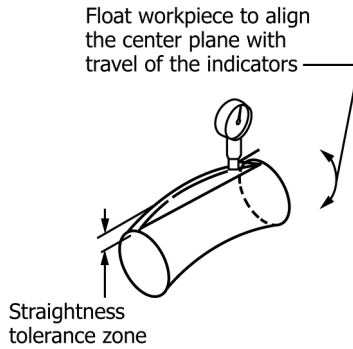

FIG. 2 Definition of a “Nonstraight” Condition

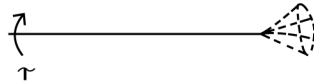

FIG. 3 Definition of Wobble in a Small Diameter Tube or Wire as it is Being Rotated



FIG. 4 Example of a Table and Granite Parallel Used to Measure Straightness by the Roll Test



FIG. 5 Example of Inclined Surface Table and Protractor Used to Measure Straightness by the Roll Test Method

typically consists of a mandrel, coil and in some cases a safety wire is used. The market for guide wires continues to grow as the number of procedures increases. For successful manufacturing of guide wires, linearity or straightness of 304 stainless steel and nitinol wire that is used for the manufacture of guide wire mandrels is critical to their end use performance. Users of guide wires require that they must navigate a tortuous anatomy.

5.1.1 A second part of minimally invasive surgery is the use of machined or formed wire, tube, or rod. In this case, straightness of rod, tube, and wire that is going to be machined or subjected to a forming practice such as bending needs to be very linear or straight so it is accurately fed into the equipment that is used for the machining or forming practice. Laser machining is an example of a machining operation that requires a wobble-free piece of rod, tubing, or wire so that it can be properly fed into the alignment bushings of the laser. Wire forming equipment also requires wobble-free material for the same reason.