



# Standard Practice for Application of Hose Stream<sup>1</sup>

This standard is issued under the fixed designation E2226; the number immediately following the designation indicates the year of original adoption or, in the case of revision, the year of last revision. A number in parentheses indicates the year of last reapproval. A superscript epsilon ( $\epsilon$ ) indicates an editorial change since the last revision or reapproval.

## INTRODUCTION

Several fire-test-response standards (such as ASTM E119, E814, E2074, and E1966) in order to assess the integrity of building elements after exposure to a specified test fire, require test specimens to be evaluated by exposure to a hose stream. It is important to standardize certain elements of the hose stream to promote uniformity in requirements. To attain this goal, this practice describes a standard apparatus for delivering a solid stream of water and prescribes a standard method of subjecting building elements to a hose stream after fire exposure.

## 1. Scope

1.1 This practice is applicable to building elements required to be subjected to the impact, erosion, and cooling effects of a hose stream as part of a fire-test-response standard. Building elements include, but are not limited to, wall and partition assemblies, fire-resistive joint systems, and doors.

1.2 This practice shall register performance of the building element under specific hose stream conditions. It shall not imply that, either after exposure or under other conditions, the structural capability of the building element is intact or that the building element is suitable for use.

1.3 The result derived from this practice is one factor in assessing the integrity of building elements after fire exposure. The practice prescribes a standard hose stream exposure for comparing performance of building elements after fire exposure and evaluates various materials and construction techniques under common conditions.

1.4 The values stated in inch-pound units are to be regarded as standard. The values given in parentheses are mathematical conversions to SI units that are provided for information only and are not considered standard.

1.5 The text of this standard references notes which provide explanatory material. These notes shall not be considered as requirements of the standard.

1.6 This fire standard cannot be used to provide quantitative measures.

1.7 *This standard does not purport to address all of the safety concerns, if any, associated with its use. It is the responsibility of the user of this standard to establish appropriate safety and health practices and determine the applicability of regulatory limitations prior to use.*

## 2. Referenced Documents

### 2.1 ASTM Standards:<sup>2</sup>

E119 Test Methods for Fire Tests of Building Construction and Materials

E176 Terminology of Fire Standards

E631 Terminology of Building Constructions

E814 Test Method for Fire Tests of Penetration Firestop Systems

E1966 Test Method for Fire-Resistive Joint Systems

E2074 Test Method for Fire Tests of Door Assemblies, Including Positive Pressure Testing of Side-Hinged and Pivoted Swinging Door Assemblies (Withdrawn 2007)<sup>3</sup>

### 2.2 UL Standard:

UL 385 Standard for Safety Play Pipes for Water Supply Testing in Fire-Protection Service<sup>4</sup>

## 3. Terminology

3.1 *Definitions*—For definitions of terms used in this practice, refer to Terminologies E176 and E631.

### 3.2 *Definitions of Terms Specific to This Standard:*

<sup>1</sup> This practice is under the jurisdiction of ASTM Committee E05 on Fire Standards and is the direct responsibility of Subcommittee E05.11 on Fire Resistance.

Current edition approved June 1, 2015. Published July 2015. Originally approved in 2002. Last previous edition approved in 2015 as E2226–15. DOI: 10.1520/E2226-15A.

<sup>2</sup> For referenced ASTM standards, visit the ASTM website, [www.astm.org](http://www.astm.org), or contact ASTM Customer Service at [service@astm.org](mailto:service@astm.org). For *Annual Book of ASTM Standards* volume information, refer to the standard's Document Summary page on the ASTM website.

<sup>3</sup> The last approved version of this historical standard is referenced on [www.astm.org](http://www.astm.org).

<sup>4</sup> Available from Underwriters Laboratories (UL), Corporate Progress, 333 Pfingsten Rd., Northbrook, IL 60062.

3.2.1 *building element, n*—a component or assembly of materials using products manufactured as independent units capable of being joined with or placed within other components or assemblies to create a structure.

3.2.2 *exposed area, n*—the total surface area of the test assembly that is subjected to the fire-resistance test including, when required, the supporting construction.

3.2.3 *fully developed stream, n*—a coherent, forceful projection of water similar in shape and intensity to the stream being applied to the exposed side of the test assembly from the nozzle.

3.2.4 *supporting construction, n*—construction required for the testing of some building elements into which the test specimen is assembled, for example, the wall into which a door is fitted.

3.2.5 *test assembly, n*—the building element or elements being tested and, if applicable, the supporting construction.

**4. Significance and Use**

4.1 This practice is intended to standardize the apparatus used and the method or pattern of application of a standard hose stream to building elements as one part of the assessment and fire resistance of building elements.

4.1.1 This practice specifies the water pressure and duration of application of the hose stream to the test assembly.

4.2 This practice is intended to be used only after a test assembly has completed a prescribed standard fire-resistance test.

4.3 The practice exposes a test assembly to a standard hose stream under controlled laboratory conditions.

4.3.1 Pass/fail criteria are defined in the appropriate fire test method.

4.3.2 This exposure is not intended to replicate typical fire fighting operations or all applied or impact loads a system could be subjected to in field use and conditions.

4.4 Any variation from tested conditions has the potential of substantially changing the performance characteristics determined by this practice.

**5. Apparatus**

5.1 The apparatus used to apply the hose stream is shown in Fig. 1 and shall be capable of delivering a solid stream of water at the pressure specified in the fire-resistance test method.

5.1.1 The water stream shall be delivered through a 2-1/2 in. (64 mm) hose discharging through a National Standard Playpipe of corresponding size equipped with a 1-1/8 in. (29 mm) discharge tip of standard taper, smooth-bore pattern without a shoulder at the orifice. Refer to UL 385.

5.1.1.1 The playpipe shall be attached at its base to a rigid support that permits the hose stream to be directed at the specimen from top to bottom and from side to side as required in 8.4 without changing the location of the base of the playpipe relative to the test specimen. The rigid base is permitted to be a wheeled apparatus that is blocked to prevent movement during the hose stream application.

NOTE 1—Typical support and swivel devices are shown in Fig. 2.

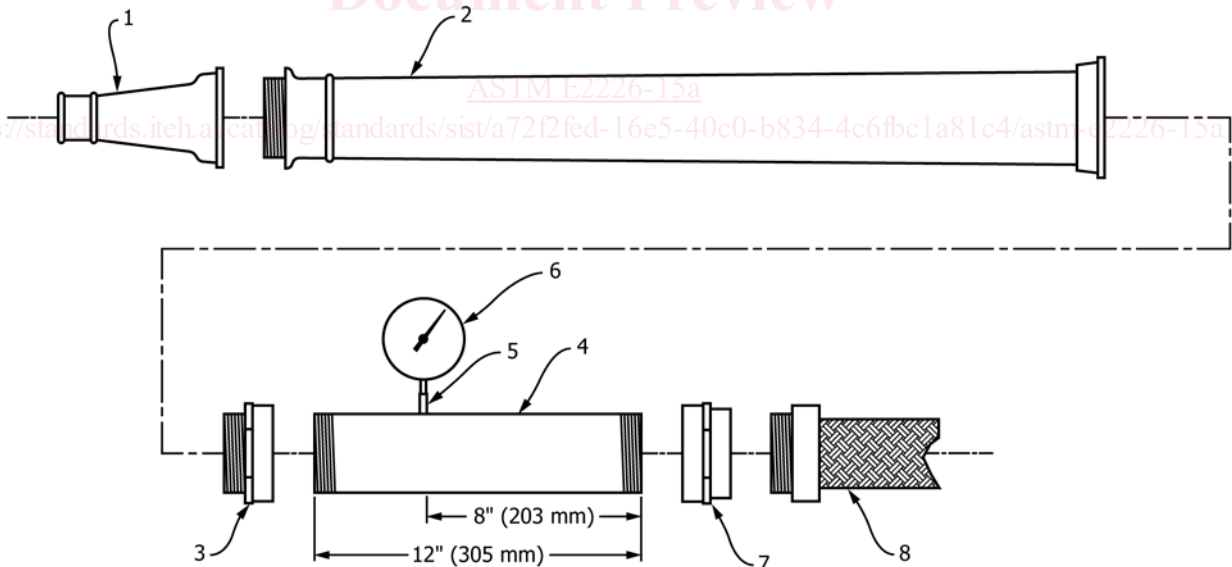

**LEGEND**

- 1. 1-1/8" [29 mm] discharge tip
- 2. 2-1/2" [64 mm] National Standard Playpipe
- 3. Adapter 2-1/2" [64 mm] hose thread (male) to 2-1/2" [64 mm] NPT (female)
- 4. 2-1/2" [64 mm] standard schedule steel pipe nipple
- 5. Pipe coupling welded or braised to the nipple, centered over a 1/8" [3.2 mm] hole in nipple
- 6. Pressure gauge
- 7. Adapter 2-1/2" [64 mm] NPT (female) to 2-1/2" [64 mm] hose thread (female)
- 8. 2-1/2" [64 mm] standard fire hose

**FIG. 1 Hose Stream Apparatus**



FIG. 2 Typical Hose Mounting Methods

(<https://standards.iteh.ai>)

5.1.2 The water pressure at the base of the nozzle shall be measured by providing a 12 in. (305 mm) length of a straight run 2-½ in. (64 mm) pipe between the hose and the playpipe. Eight inches downstream from one end, the pipe shall have an ⅛ in. (3.2 mm) diameter pressure tap drilled through the pipe sidewall with a pipe coupling welded or brazed concentrically over the hole. The pressure tap shall be flush with and perpendicular ( $\pm 5^\circ$ ) to the inner wall of the pipe. Burrs or other irregularities shall be removed or corrected.

5.1.3 A pressure gauge calibrated in 1 psi (5 kPa) increments shall be fitted on the end of the coupling. The pressure gauge shall be capable of reading a maximum pressure of at least 59 psi (406 kPa) and shall have a full scale reading no greater than 300 psi (2070 kPa).

5.2 The hose stream apparatus shall be connected to a source of water capable of maintaining the required minimum pressure, as specified in the fire-resistance test method, at the nozzle under flow conditions throughout the hose stream test.

## 6. Test Specimen and Conditioning

6.1 Prior to conducting the hose stream test, the test specimen shall be conditioned and fire tested as specified in the applicable fire-resistance test method.

## 7. Nozzle Location

7.1 The nozzle tip shall be located so that its axis is  $90^\circ$  to the center of the test assembly as shown in Fig. 3. However, if the axis is other than  $90^\circ$ , refer to 7.2.1.

7.2 The distance between the center of the test assembly and the nozzle tip shall be  $20 \pm 1$  ft ( $6.1 \pm 0.3$  m) as shown in Fig. 3.

7.2.1 The distance specified in 7.2 shall be decreased by 1 ft (305 mm) for each  $10^\circ$  deviation from the normal as shown in Fig. 4. The maximum deviation from the normal shall not exceed  $30^\circ$ .

## 8. Procedure

8.1 Prior to the fire test, the laboratory shall ensure that the discharge pressure specified in the fire-resistance test method is capable of being attained.

8.2 Condition and fire test the test specimen in accordance with the requirements of the fire-resistance test method.

8.3 Unless otherwise specified, immediately, but not longer than 10 min after the termination of the fire test, perform all of the following prior to the application of the hose stream:

8.3.1 Remove the test assembly and frame from the furnace, when applicable.

8.3.2 Position the test assembly in such a manner as to be able to apply the hose stream to the entire surface of the test assembly that had been exposed to the fire.

8.3.3 Position the tip of the nozzle at the specified distance from the center of the test assembly.

8.3.4 Adjust the nozzle hose stream to the pressure specified in Table 1. During adjustment, the hose stream shall not contact the test assembly.