



Designation: **E595–07** E595–15

Standard Test Method for Total Mass Loss and Collected Volatile Condensable Materials from Outgassing in a Vacuum Environment¹

This standard is issued under the fixed designation E595; the number immediately following the designation indicates the year of original adoption or, in the case of revision, the year of last revision. A number in parentheses indicates the year of last reapproval. A superscript epsilon (ϵ) indicates an editorial change since the last revision or reapproval.

This standard has been approved for use by agencies of the U.S. Department of Defense.

1. Scope

1.1 This test method covers a screening technique to determine volatile content of materials when exposed to a vacuum environment. Two parameters are measured: total mass loss (TML) and collected volatile condensable materials (CVCM). An additional parameter, the amount of water vapor regained (WVR), can also be obtained after completion of exposures and measurements required for TML and CVCM.

1.2 This test method describes the test apparatus and related operating procedures for evaluating the mass loss of materials being subjected to 125°C at less than 7×10^{-33} Pa (5×10^{-5} ~~torr~~ ~~torr~~) for 24 h. The overall mass loss can be classified into noncondensables and condensables. The latter are characterized herein as being capable of condensing on a collector at a temperature of 25°C.

NOTE 1—Unless otherwise noted, the tolerance on 25 and 125°C is $\pm 1^\circ\text{C}$ and on 23°C is $\pm 2^\circ\text{C}$. The tolerance on relative humidity is $\pm 5\%$.

1.3 Many types of organic, polymeric, and inorganic materials can be tested. These include polymer potting compounds, foams, elastomers, films, tapes, insulations, shrink tubings, adhesives, coatings, fabrics, tie cords, and lubricants. The materials may be tested in the “as-received” condition or prepared for test by various curing specifications.

1.4 This test method is primarily a screening technique for materials and is not necessarily valid for computing actual contamination on a system or component because of differences in configuration, temperatures, and material processing.

1.5 The criteria used for the acceptance and rejection of materials shall be determined by the user and based upon specific component and system requirements. Historically, TML of 1.00 % and CVCM of 0.10 % have been used as screening levels for rejection of spacecraft materials.

1.6 The use of materials that are deemed acceptable in accordance with this test method does not ensure that the system or component will remain uncontaminated. Therefore, subsequent functional, developmental, and qualification tests should be used, as necessary, to ensure that the material’s performance is satisfactory.

1.7 *This standard does not purport to address all of the safety concerns associated with its use. It is the responsibility of the user of this standard to establish appropriate safety and health practices and determine the applicability of regulatory limitations prior to use.*

2. Referenced Documents

2.1 *ASTM Standards:*²

[E177 Practice for Use of the Terms Precision and Bias in ASTM Test Methods](#)

2.2 *ASTM Adjuncts:*

Micro VCM Detailed Drawings³

3. Terminology

3.1 *Definitions:*

¹ This test method is under the jurisdiction of ASTM Committee E21 on Space Simulation and Applications of Space Technology and is the direct responsibility of Subcommittee E21.05 on Contamination.

Current edition approved Dec. 1, 2007; May 1, 2015. Published December 2007/July 2015. Originally approved in 1977. Last previous edition approved in 2006/2007 as E595–06/E595–07. DOI: 10.1520/E0595-07-10.1520/E0595-15.

² For referenced ASTM standards, visit the ASTM website, www.astm.org, or contact ASTM Customer Service at service@astm.org. For Annual Book of ASTM Standards volume information, refer to the standard’s Document Summary page on the ASTM website.

³ Available from ASTM International, 100 Barr Harbor Dr., PO Box C700, West Conshohocken, PA 19428–2959. Order Adjunct [ADJE0595](#).

3.1.1 *collected volatile condensable material, CVCM*—the quantity of outgassed matter from a test specimen that condenses on a collector maintained at a specific constant temperature for a specified time. CVCM is expressed as a percentage of the initial specimen mass and is calculated from the condensate mass determined from the difference in mass of the collector plate before and after the test.

3.1.2 *total mass loss, TML*—total mass of material outgassed from a specimen that is maintained at a specified constant temperature and operating pressure for a specified time. TML is calculated from the mass of the specimen as measured before and after the test and is expressed as a percentage of the initial specimen mass.

3.1.3 *water vapor regained, WVR*—the mass of the water vapor regained by the specimen after the optional reconditioning step. WVR is calculated from the differences in the specimen mass determined after the test for TML and CVCM and again after exposure to a 50 % relative humidity atmosphere at 23°C for 24 h. WVR is expressed as a percentage of the initial specimen mass.

4. Summary of Test Method

4.1 This microvolatile condensable system⁴ was developed from an earlier system for determination of macrovolatile condensables that required much larger samples and a longer test.

4.2 The test specimen is exposed to 23°C and 50 % relative humidity for 24 h in a preformed, degreased container (boat) that has been weighed. After this exposure, the boat and specimen are weighed and put in one of the specimen compartments in a copper heating bar that is part of the test apparatus. The copper heating bar can accommodate a number of specimens for simultaneous testing. The vacuum chamber in which the heating bar and other parts of the test apparatus are placed is then sealed and evacuated to a vacuum of at least 7×10^{-3} Pa (5×10^{-5} torr). The heating bar is used to raise the specimen compartment temperature to 125°C. This causes vapor from the heated specimen to stream from the hole in the specimen compartment. A portion of the vapor passes into a collector chamber in which some vapor condenses on a previously-weighed and independently temperature-controlled, chromium-plated collector plate that is maintained at 25°C. Each specimen compartment has a corresponding collector chamber that is isolated from the others by a compartmented separator plate to prevent cross contamination. After 24 h, the test apparatus is cooled and the vacuum chamber is repressurized with a dry, inert gas. The specimen and the collector plates are weighed. From these results and the specimen mass determined before the vacuum exposure, the percentage TML and percentage CVCM are obtained. Normally, the reported values are an average of the percentages obtained from three samples of the same material.

NOTE 2—It is also possible to conduct infrared and other analytical tests on the condensates in conjunction with mass-loss tests. Sodium chloride flats may be used for infrared analysis. These flats are nominally 24 mm (1 in.) in diameter by 3.2 mm (0.125 in.) thick and are supported edgewise in a metal holder that fits into the collector plate receptacle. On completion of the test, the flats are placed into an infrared salt flat holder for examination by an infrared spectrophotometer. As an alternative method, the condensate may be dissolved from the metallic collector, the solvent evaporated, and the residue deposited on a salt flat for infrared tests. Sodium chloride flats shall not be used for CVCM determinations.

4.3 After the specimen has been weighed to determine the TML, the WVR can be determined, if desired, as follows: the specimen is stored for 24 h at 23°C and 50 % relative humidity to permit sorption of water vapor. The specimen mass after this exposure is determined. From these results and the specimen mass determined after vacuum exposure, the percentage WVR is obtained.

4.4 Two or three empty specimen chambers in the heater bar and collector plates on the cold bar, selected for each test at random, can be used as controls to ensure that uniform cleaning procedures have been followed after each test.

4.5 A typical test apparatus can have 24 specimen chambers with 24 associated collector plates so that a number of specimens of different types can be tested each time the foregoing operations are conducted. Three specimen compartments can serve as controls and three can be used for each type of material being tested. The total time required for specimens requiring no prior preparation is approximately 4 days. The equipment should be calibrated at least once a year by using previously tested materials as test specimens. The reference sample should be selected from materials that had a narrow range of TML and VCM results when tested originally.

4.6 The apparatus may be oriented in any direction as long as the configuration shown in Fig. 1 is maintained and bulk material does not fall from the sample holder nor obstruct the gas-exit hole. The dimensions for critical components given in Fig. 2 and Table 1 are provided so that apparatus constructed for the purpose of this test may provide uniform and comparable results.

5. Significance and Use

5.1 This test method evaluates, under carefully controlled conditions, the changes in the mass of a test specimen on exposure under vacuum to a temperature of 125°C and the mass of those products that leave the specimen and condense on a collector at a temperature of 25°C.

⁴ Muraca, R. F., and Whittick, J. S., "Polymers for Spacecraft Applications." SRI Project ASD-5046, NASA CR-89557, N67-40270, Stanford Research Institute, September 1967.

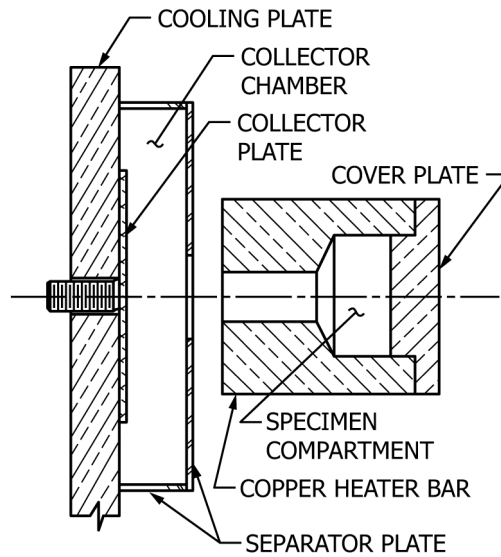

FIG. 1 Schematic of Critical Portion of Test Apparatus (Section A-A of Fig. 2)

5.2 The 24 h test time does not represent actual outgassing from years of operation, so a higher test temperature shorter time was selected to allow material comparisons with no intent to predict actual outgassing in service. The test temperature of 125°C was assumed to be significantly above the expected operating temperature in service. If expected operating temperatures exceed 65 to 70°C the test temperature should be increased. It is suggested that test temperature be at least 30°C higher than expected maximum service temperature in order to provide material comparisons for TML and CVCM.

5.3 Comparisons of material outgassing properties are valid at 125°C sample temperature and 25°C collector temperature only. Samples tested at other temperatures may be compared only with other materials which were tested at that same temperature.

5.4 The measurements of the collected volatile condensable material are also comparable and valid only for similar collector geometry and surfaces at 25°C. Samples have been tested at sample temperatures from 50 to 400°C and at collector temperatures from 1 to 30°C by this test technique. Data taken at nonstandard conditions must be clearly identified and should not be compared with samples tested at 125°C sample temperature and 25°C collector temperature.

5.5 The simulation of the vacuum of space in this test method does not require that the pressure be as low as that encountered in interplanetary flight (for example, 10^{-12} Pa (10^{-14} torr)). It is sufficient that the pressure be low enough that the mean free path of gas molecules be long in comparison to chamber dimensions.

5.6 This method of screening materials is considered a conservative one because maximum operating temperatures in service are assumed not to exceed 50 to 60°C for most applications. It is possible that a few materials will have acceptable properties at the intended use temperature but will be eliminated because their properties are not satisfactory at the test temperature of 125°C. Also, materials that condense only below 25°C are not detected. The user may designate additional tests to qualify materials for a specific application.

5.7 The determinations of TML and WVR are affected by the capacity of the material to gain or lose water vapor. Therefore, the weighings must be accomplished under controlled conditions of 23°C and 50 % relative humidity.

5.8 Alternatively, all specimens may be put into open glass vials during the 24-h temperature and humidity conditioning. The vials must be capped before removal from the conditioning chamber. Each specimen must be weighed within 2 min after opening the vial to minimize the loss or absorption of water vapor while exposed to an uncontrolled humidity environment. While control of humidity is not necessary at this point, the temperature for the weighing should be controlled at 23°C, the same temperature prescribed for the 24-h storage test.

6. Apparatus

6.1 The apparatus used in the determination of TML and CVCM typically contains two resistance-heated copper bars. Generally, each bar is 650 mm (25.5 in.) in length with a 25-mm (1-in.) square cross section and contains twelve specimen chambers. The open section of each specimen chamber allows vapors from the specimen to pass through a hole into a collector chamber where it impinges on a removable chromium-plated collector plate maintained at 25°C throughout the test. (See Figs. 1 and 2.) Variations in test apparatus configurations are acceptable if critical dimensions are maintained as prescribed in Table 1.

6.2 Typically, a total of 24 specimen chambers is used for testing during a 24-h vacuum operation; 3 of the chambers are maintained as controls. The test apparatus can be mounted on the base plate of a vacuum system within a narrow vacuum bell, 260 mm (10¼ in.) in diameter, that rests on a specially adapted feed-through collar, also supported by the base plate.

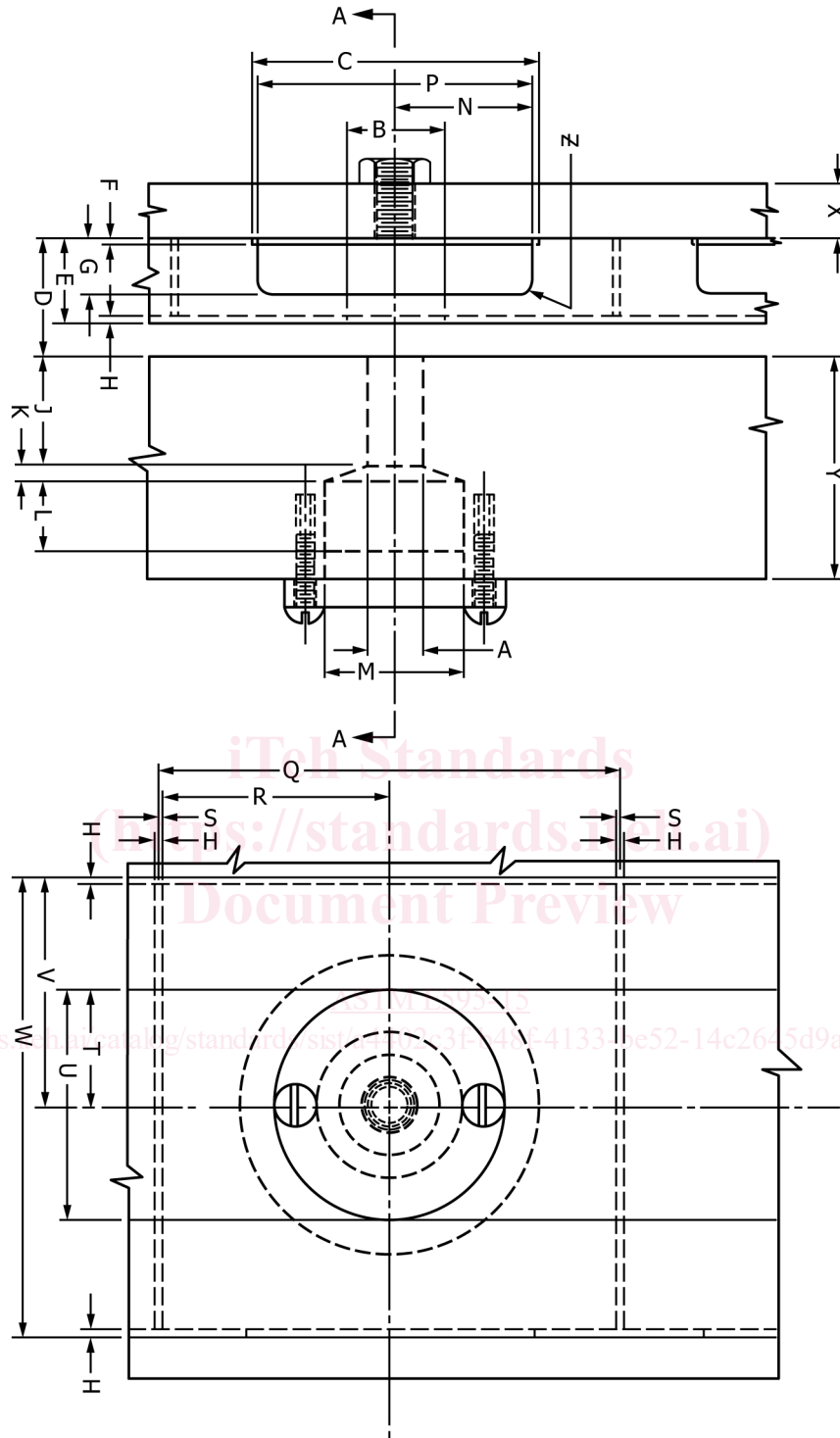

FIG. 2 Critical Portion of Test Apparatus (See Table 1 for Dimensions)

6.3 The operation of the vacuum chamber system and any device for raising the vacuum bell can be automatically controlled. Power to the heating element mounted in the copper bars is generally controlled by variable transformers through temperature controllers. Recorders with an electronic icepoint reference junction feedback may be used to monitor the heater bar temperatures. A heat exchanger using a suitable fluid may be used to maintain the collector plate at 25°C during the test.⁴

6.4 It is recommended that the vacuum chamber system include automatic controls to prevent damage in the event of power failure or cooling fluid supply failure when in unattended operation. Care must be taken to prevent backstreaming of oil from vacuum or diffusion pumps into the vacuum chamber.

TABLE 1 Test Apparatus Dimensions (See Fig. 2)

Letter	mm	Tolerance	in.	Tolerance	Notes
A ^A	6.3	±0.1	0.250	±0.005	diameter ^B
B ^A	11.1	±0.1	0.438	±0.005	diameter ^B
C ^A	33.0	±0.1	1.300	±0.005	diameter ^B
D ^{AC}	13.45	±0.10	0.531	±0.005	
E ^{AC}	12.7	±0.10	0.500	±0.005	
F ^{AC}	0.65	±0.10	0.026	±0.005	
G ^C	9.65	±0.3	0.380	±0.01	
H ^A	0.75	±0.10	0.030	±0.05	stock size
J ^A	12.7	±0.3	0.500	±0.010	
K	1.6	±0.8	1/16	±1/32	
L	8.0	±0.8	7/16	±1/32	
M	16.0	±0.1	0.625	±0.005	cover plate must fit snugly
N	16.0	±0.8	5/8	±1/32	
P	32.0	±0.8	1 1/4	±1/32	
Q	50.0	±0.8	2	±1/32	
R	25.5	±0.8	1	±1/32	
S	0.4	±0.3	0.015	±0.010	half stock thickness
T	12.0	±0.8	1/2	±1/32	
U	25.5	±0.8	1	±1/32	
V	25.5	±0.8	1	±1/32	
W	50.0	±0.8	2	±1/32	
X	6.0	±0.8	1/4	±1/32	
Y	25.0	±0.8	1	±1/32	
Z	1.6	±0.8	1/16	±1/32	radius, typical

^A Critical dimensions that must be maintained for test results to be comparable.

^B Diameters must be concentric to ±0.1 mm (±0.005 in.) for test results to be comparable.

^C Dimensions include plating thickness. Satisfactory surfaces have been produced by making substrate surface finish, 1.6-µm RMS (63-µin. RMS), highly polished, plated with electroless nickel, 0.0127 mm (0.0005 in.) thick, and finished with electroplated chromium, 0.0051 mm (0.0002 in.) thick.

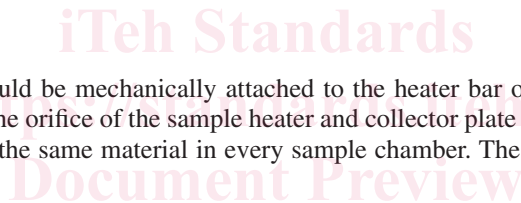

6.5 The controller thermocouple should be mechanically attached to the heater bar or ring to prevent the thermocouple from loosening over time. It is essential that the orifice of the sample heater and collector plate be aligned and checked regularly. A good test of alignment and stability is to run the same material in every sample chamber. The results should agree within the accuracy of the test per Section 11.

7. Test Specimen

7.1 Finished products (for example, elastomers, hardware, and structural parts) are cut into small pieces on the order of 1.5- to 3.0-mm (1/16- to 1/8-in.) cubes to fit into the specimen boat. Boats approximately 10 by 6 by 12 mm (3/8 by 1/4 by 1/2 in.) have been found satisfactory.

7.2 Products that require compounding are normally mixed in 10-g batches to ensure representative samples. Materials shall be cured as sheets, thin slabs, or thicker sections to simulate application in actual use; then they shall be sectioned in accordance with the foregoing dimensions for specimen cubes. Mix ratios and cure cycles for the test samples should be the same as those normally used for the material.

7.3 Adhesive tapes shall be applied to a surface, such as a preweighed aluminum ring or foil, to simulate actual use. Paints can be applied to aluminum foil by brushing, dipping, or spraying to approximate the as-used thickness, then cured before testing. A paint can also be cured on an inert surface such as TFE-fluorocarbon, removed as a film, and treated as bulk material. Some adhesives or sealants may be applied to preweighed aluminum foil and ~~cured~~ cured, but normally these materials are cured as small blocks and then cut into test samples.

7.4 Greases shall be placed into a boat. Liquids shall be placed directly in a boat or absorbed in an ignited neutral filler such as silica and then placed in a boat. The technique used shall be stated in the report. Liquids and greases, especially silicones, are prone to creep; if the material exhibits creep to such an extent that some flows out of the boat, the test results shall be disregarded.

7.5 Minimum specimen masses on the order of 200 mg are required. If smaller quantities are used, the accuracy of the measurements may be impaired.

7.6 It is absolutely essential that specimen materials not be contaminated at any step in the specimen fabrication process. Most importantly, specimen material shall not be handled with the bare hands as oils from human skin are volatile and condensable and thus will cause false TML and CVCM results.

7.7 The following specimen handling procedures are recommended to control contamination:

7.7.1 Wear suitable gloves or finger cots during all specimen preparation steps.

7.7.2 All previously prepared materials can be assumed to be contaminated in the “as-received” condition and must be cleaned.

7.7.3 Use cleaning solvents that are known to be nonreactive with the specimen material and that are known to leave no residue.

7.7.4 When possible, discard exterior surfaces of materials when preparing specimens. A clean razor blade can be used to shave off exterior surfaces of rubbers, foams, and other soft materials. Exterior surfaces of harder materials can be removed with a clean jewelers' saw. A clean jewelers' drill can be used to remove specimen material from the center part of material suspected of being contaminated.

8. Procedure

8.1 Weigh a prepared aluminum foil boat and return it to its storage beaker in a glass desiccator using silica gel desiccant.

8.2 Weigh a prepared collector and mount it into its cooling-plate receptacle.

8.3 Add the test specimen (100 to 300 mg) to the boat and condition the sample at 50 % relative humidity and 23°C for a minimum of 24 h.

8.4 Weigh the conditioned specimen (see 4.6) using a balance having $\pm 1\text{-}\mu\text{g}$ sensitivity.

8.5 Place the specimen and boat into a specimen compartment of the heating bar in the microvolatile condensable system.⁴

NOTE 3—Before the operation noted in 8.5, the copper compartment bar, separator, and cooling plate shall be clean, in position, and awaiting the specimen boats and collector plates.

8.6 Mount and screw down the respective cover plates onto the entry end of each specimen compartment.

8.7 Close the vacuum system and evacuate it to 7×10^{-3} Pa (5×10^{-5} torr) or less within 1 h, using proper operating procedures.

8.8 Control of the collector plate temperature at 25°C (or other temperature if a nonstandard test is being conducted) shall be achieved within the first hour of pump-down.

8.9 When a pressure of 7×10^{-3} Pa (5×10^{-5} torr) is reached, turn on the heater bar and adjust the variable transformers to raise the heater bar temperature to 125°C (or other nonstandard test temperature) within 60 min. If the sample temperature will exceed 150°C, up to 2 h may be required to reach temperature. Temperature controllers should maintain bar temperatures at 125°C (or other desired temperature).

8.10 Maintain the collector plate temperatures at 25°C (or other nonstandard temperature).

8.11 Maintain the heater bar temperature at 125°C (or other nonstandard temperature) for 24 h, then close the high vacuum valve to the pumping system and turn off the heater bar current.

8.12 Open the vent valve and backfill with clean, dry nitrogen regulated within a gage pressure range from 10 to 30 kPa (2 to 4 psi) above atmosphere to cool the bars rapidly.

8.13 Allow the heater bar to cool sufficiently to permit handling (nominally 2 h to reach 50°C). Then turn off the collector-plate heat exchangers, return the vacuum chamber to room pressure using the clean, dry nitrogen, and open the chamber.

8.14 Store aluminum boats with specimens and respective collector plates in desiccators (using active silica gel desiccant) immediately. After specimens have cooled to approximately room temperature, but no longer than $\frac{1}{2}$ h, remove and weigh each specimen within 2 min of its removal from the desiccators. Control collector plates are used to detect cross contamination or poor technique. Mass loss of greater than 20 μg by a control is usually due to poor preparation and cleaning of the collector plate. Mass gain of greater than 50 μg is an indication of poor cleaning, poor bakeout of the heater assembly, cross contamination, or poor vacuum technique. Any change of 50 μg (0.05 % of a 100-mg control mass) or greater is reason for concern and for a review of or change in techniques. All data acquired during runs when this occurs shall be discarded or retained with a note indicating the discrepancy.

8.15 Return the foregoing samples to the relative humidity chamber for 24 h if the WVR is to be determined. Weigh the conditioned specimens (see 5.7).

NOTE 4—Annex A1 contains recommended cleaning and storage procedures.

9. Calculation

9.1 Calculate TML as follows:

	Initial Mass, g	Final Mass, g
Specimen and boat	$S_i + B_i$	$S_f + B_f$
Boat	B_i	B_f
Specimen alone	$(S_i + B_i) - B_i = S_i$	$(S_f + B_f) - B_f = S_f$
Difference or mass loss	$L = S_i - S_f$	
	$L/S_i \times 100 = \% \text{ TML}$	