



Designation: **E1419—09 E1419/E1419M – 15**

Standard Practice for Examination of Seamless, Gas-Filled, Pressure Vessels Using Acoustic Emission¹

This standard is issued under the fixed designation ~~E1419~~; E1419/E1419M; the number immediately following the designation indicates the year of original adoption or, in the case of revision, the year of last revision. A number in parentheses indicates the year of last reappraisal. A superscript epsilon (ϵ) indicates an editorial change since the last revision or reappraisal.

1. Scope—~~Scope*~~

1.1 This practice provides guidelines for acoustic emission (AE) examinations of seamless pressure vessels (tubes) of the type used for distribution or storage of industrial gases.

1.2 This practice requires pressurization to a level greater than normal use. Pressurization medium may be gas or liquid.

1.3 This practice does not apply to vessels in cryogenic service.

1.4 The AE measurements are used to detect and locate emission sources. Other nondestructive test (NDT) methods must be used to evaluate the significance of AE sources. Procedures for other NDT techniques are beyond the scope of this practice. See [Note 1](#).

NOTE 1—Shear wave, angle beam ultrasonic examination is commonly used to establish circumferential position and dimensions of flaws that produce AE. Time of Flight Diffraction (TOFD), ultrasonic examination is also commonly used for flaw sizing.

1.5 The values stated in either SI units or inch-pound units are to be regarded separately as the standard. ~~The values given in parentheses are for information only.~~ stated in each system may not be exact equivalents; therefore, each system shall be used independently of the other. Combining values from the two systems may result in non-conformance with the standard.

1.6 *This standard does not purport to address all of the safety concerns, if any, associated with its use. It is the responsibility of the user of this standard to establish appropriate safety and health practices and determine the applicability of regulatory limitations prior to use.* Specific precautionary statements are given in Section 7.

2. Referenced Documents

2.1 ASTM Standards:²

[E543 Specification for Agencies Performing Nondestructive Testing](#)

[E650 Guide for Mounting Piezoelectric Acoustic Emission Sensors](#)

[E976 Guide for Determining the Reproducibility of Acoustic Emission Sensor Response](#)

[E1316 Terminology for Nondestructive Examinations](#)

[E2223 Practice for Examination of Seamless, Gas-Filled, Steel Pressure Vessels Using Angle Beam Ultrasonics](#)

[E2075 Practice for Verifying the Consistency of AE-Sensor Response Using an Acrylic Rod](#)

[E2374 Guide for Acoustic Emission System Performance Verification](#)

2.2 ASNT Standards:³

[Recommended Practice SNT-TC-1A for Nondestructive Testing Personnel Qualification and Certification](#)

[ANSI/ASNT CP-189 Standard for Qualification and Certification of Nondestructive Testing Personnel](#)

2.3 Code of Federal Regulations:

[Section 49, Code of Federal Regulations, Hazardous Materials Regulations of the Department of Transportation, Paragraphs 173.34, 173.301, 178.36, 178.37, and 178.45⁴](#)

~~2.5 Compressed Gas Association Standard:~~

¹ This practice is under the jurisdiction of ASTM Committee E07 on Nondestructive Testing and is the direct responsibility of Subcommittee E07.04 on Acoustic Emission Method.

Current edition approved Feb. 1, 2009; June 1, 2015. Published February 2009; July 2015. Originally approved in 1991. Last previous edition approved in 2002 as E1419—02b; E1419—09. DOI: 10.1520/E1419-09; 10.1520/E1419_E1419M-15.

² For referenced ASTM standards, visit the ASTM website, www.astm.org, or contact ASTM Customer Service at service@astm.org. For *Annual Book of ASTM Standards* volume information, refer to the standard's Document Summary page on the ASTM website.

³ Available from American Society for Nondestructive Testing (ASNT), P.O. Box 28518, 1711 Arlington Ln., Columbus, OH 43228-0518, <http://www.asnt.org>.

⁴ Available from U.S. Government Printing Office Superintendent of Documents, 732 N. Capitol St., NW, Mail Stop: SDE, Washington, DC 20401, <http://www.access.gpo.gov>.

*A Summary of Changes section appears at the end of this standard

[Pamphlet C-5 Service Life, Seamless High Pressure Cylinders⁵](#)

[2.4 Compressed Gas Association Standard:⁵](#)

[Pamphlet C-5 Service Life, Seamless High Pressure Cylinders](#)

[CGA-C18 Methods for Acoustic Emission Requalification of Seamless Steel Compressed Gas Tubes](#)

[2.5 AIA Document:](#)

[NAS-410 Certification and Qualification of Nondestructive Testing Personnel⁶](#)

[2.6 ISO Standards:⁷](#)

[ISO 9712 Non-destructive Testing—Qualification and Certification of NDT Personnel](#)

[ISO 16148 Gas Cylinders—Acoustic Emission Testing \(AT\) for Periodic Inspection](#)

3. Terminology

3.1 *Definitions*—See Terminology [E1316](#) for general terminology applicable to this practice.

3.2 *Definitions of Terms Specific to This Standard:*

3.2.1 *fracture critical flaw*—a flaw that is large enough to exhibit unstable growth at service conditions.

3.2.2 *marked service pressure*—pressure for which a vessel is rated. Normally this value is stamped on the vessel.

3.2.3 *normal fill pressure*—level to which a vessel is pressurized. This may be greater, or may be less, than *marked service pressure*.

4. Summary of Practice

4.1 The AE sensors are mounted on a vessel, and emission is monitored while the vessel is pressurized above normal fill pressure.

4.2 Sensors are mounted at each end of the vessel and are connected to an acoustic emission signal processor. The signal processor uses measured times of arrival of emission bursts to determine linear location of emission sources. If measured emission exceeds a prescribed level (that is, specific locations produce enough events), then such locations receive secondary NDT (for example, ultrasonic examination).

4.3 Secondary examination establishes presence of flaws and measures flaw dimensions.

4.4 If flaw depth exceeds a prescribed limit (that is, a conservative limit that is based on construction material, wall thickness, fatigue crack growth estimates, and fracture critical flaw depth calculations), then the vessel must be removed from service.

5. Significance and Use

5.1 Because of safety considerations, regulatory agencies (for example, U.S. Department of Transportation) require periodic examinations of vessels used in transportation of industrial gases (see Section 49, Code of Federal Regulations). The AE examination has become accepted as an alternative to the common hydrostatic proof test. In the common hydrostatic test, volumetric expansion of vessels is measured.

5.2 An AE examination should not be ~~used~~ performed for a period of one year after a common hydrostatic test. See [Note 2](#).

NOTE 2—The Kaiser effect relates to decreased emission that is expected during a second pressurization. Common hydrostatic tests use a relatively high pressure (167 % of normal service pressure). (See Section 49, Code of Federal Regulations.) If an AE examination is performed too soon after such a pressurization, the AE results will be insensitive to a lower examination pressure (that is, the lower pressure that is associated with an AE examination).

5.3 *Pressurization:*

5.3.1 General practice in the gas industry is to use low pressurization rates. This practice promotes safety and reduces equipment investment. The AE examinations should be performed with pressurization rates that allow vessel deformation to be in equilibrium with the applied load. Typical current practice is to use rates that approximate 500 psi/h (3.453.45 MPa/h [500 psi/MPa/h]-h).

5.3.2 Gas compressors heat the pressurizing medium. After pressurization, vessel pressure may decay as gas temperature equilibrates with ambient conditions.

5.3.3 Emission from flaws is caused by flaw growth and secondary sources (for example, crack surface contact and contained mill scale). Secondary sources can produce emission throughout vessel pressurization.

5.3.4 When pressure within a vessel is low, and gas is the pressurizing medium, flow velocities are relatively high. Flowing gas (turbulence) and impact by entrained particles can produce measurable emission. Considering this, acquisition of AE data may commence at some pressure greater than starting pressure (for example, 1/3 of maximum examination pressure).

5.3.5 *Maximum Test Pressure*—Serious flaws usually produce more acoustic emission (that is, more events, events with higher peak amplitude) from secondary sources than from flaw growth. When vessels are pressurized, flaws produce emission at pressures

⁵ Available from Compressed Gas Association (CGA), 4221 Walney Rd., 5th Floor, Chantilly, VA 20151-2923, <http://www.cganet.com>.

⁶ Available from Aerospace Industries Association of America, Inc. (AIA), 1000 Wilson Blvd., Suite 1700, Arlington, VA 22209-3928, <http://www.aia-aerospace.org>.

⁷ Available from International Organization for Standardization (ISO), 1, ch. de la Voie-Creuse, CP 56, CH-1211 Geneva 20, Switzerland, <http://www.iso.org>.

less than normal fill pressure. A maximum examination pressure that is 10 % greater than normal fill pressure allows measurement of emission from secondary sources in flaws and from flaw growth.

5.3.6 *Pressurization Schedule*—Pressurization should proceed at rates that do not produce noise from the pressurizing medium and that allow vessel deformation to be in equilibrium with applied load. Pressure holds are not necessary; however, they may be useful for reasons other than measurement of AE.

5.4 Excess background noise may distort AE data or render them useless. Users must be aware of the following common sources of background noise: high gas-fill rate (measurable flow noise); mechanical contact with the vessel by objects; electromagnetic interference (EMI) and radio frequency interference (RFI) from nearby broadcasting facilities and from other sources; leaks at pipe or hose connections; and airborne sand particles, insects, or rain drops. This practice should not be used if background noise cannot be eliminated or controlled.

5.5 Alternate procedures are found in ISO 16148 and CGA C18. These include hydrostatic proof pressurization of individual vessels and data interpretation using modal analysis techniques

6. Basis of Application

6.1 The following items are subject to contractual agreement between the parties using or referencing this practice.

6.2 *Personnel Qualification*—If specified in the contractual agreement, personnel performing examinations to this standard shall be qualified in accordance with a nationally or internationally recognized NDT personnel qualification practice or standard such as ANSI/ASNT-CP-189, SNT-TC-1A, NAS-410, ISO 9712, or a similar document and certified by the employer or certifying agency, as applicable. The practice or standard used and its applicable revision shall be identified in the contractual agreement between the using parties.

6.3 *Qualification of Nondestructive Agencies*—If specified in the contractual agreement, NDT agencies shall be qualified and evaluated as described in Practice E543. The applicable edition of Practice E543 shall be specified in the contractual agreement.

6.4 *Time of Examination*—The timing of examination shall be in accordance with 5.2 unless otherwise specified.

6.5 *Extent of Examination*—The extent of examination includes the entire pressure vessel unless otherwise specified.

6.6 *Reporting Criteria/Acceptance Criteria*—Reporting criteria for the examination results shall be in accordance with Section 11 unless otherwise specified. Since acceptance criteria (for example, reference radiographs) are not specified in this practice, they shall be specified in the contractual agreement.

6.7 *Reexamination of Repaired/Reworked Items*—Reexamination of repaired/reworked items is not addressed in this practice and if required shall be specified in the contractual agreement.

7. Apparatus

7.1 Essential features of the apparatus required for this practice are provided in Fig. 1. Full specifications are in Annex A1.

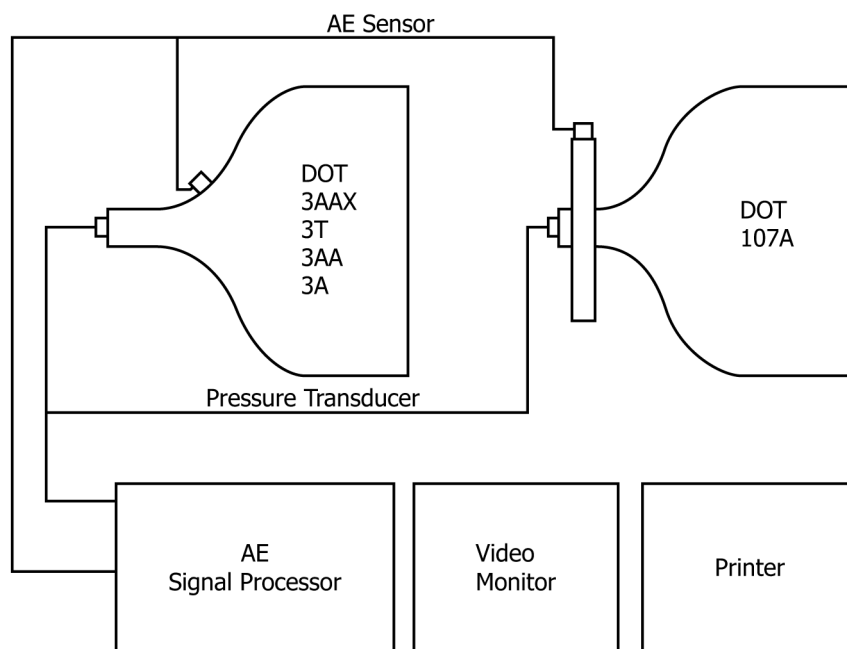

FIG. 1 Essential Features of the Apparatus with Typical Sensor Placements

7.2 Couplant must be used to acoustically connect sensors to the vessel surface. Adhesives that have acceptable acoustic properties, and adhesives used in combination with traditional couplants, are acceptable.

7.3 Sensors may be held in place with magnets, adhesive tape, or other mechanical means.

7.4 The AE sensors are used to detect strain-induced stress waves produced by flaws. Sensors must be held in contact with the vessel wall to ensure adequate acoustic coupling.

7.5 A preamplifier may be enclosed in the sensor housing or in a separate enclosure. If a separate preamplifier is used, cable length, between sensor and preamp, must not exceed ~~6 ft (1.83 m)~~; 2 m [6.6 ft].

7.6 Power/signal cable length (that is, cable between preamp and signal processor) shall not exceed ~~500 ft (152.4 m)~~; 150 m [500 ft]. See **A1.5**.

7.7 Signal processors are computerized instruments with independent channels that filter, measure, and convert analog information into digital form for display and permanent storage. A signal processor must have sufficient speed and capacity to independently process data from all sensors simultaneously. The signal processor should provide capability to filter data for replay. A printer should be used to provide hard copies of examination results.

7.7.1 A video monitor should display processed examination data in various formats. Display format may be selected by the equipment operator.

7.7.2 A data storage device, ~~such as a floppy disk, device~~ may be used to provide data for replay or for archives.

7.7.3 Hard copy output capability should be available from a ~~graphics/line~~ printer or equivalent device.

8. Safety Precautions

8.1 As in any pressurization of metal vessels, ambient temperature should not be below the ductile-brittle transition temperature of the pressure vessel construction material.

9. Calibration and Standardization

9.1 Annual calibration and verification of pressure transducer, AE sensors, preamplifiers (if applicable), signal processor (particularly the signal processor time reference), and AE electronic waveform generator should be performed. Equipment should be adjusted so that it conforms to equipment manufacturer's specifications. Instruments used for calibrations must have current accuracy certification that is traceable to the National Institute for Standards and Technology (NIST).

9.2 Routine electronic evaluation of the signal processor should be performed monthly and any time there is concern about signal processor performance. An AE electronic waveform generator should be used in making evaluations. Each signal processor channel must respond with peak amplitude reading within ± 2 dBV of the electronic waveform generator output.

9.3 Routine evaluation of the sensors should be performed monthly. An accepted procedure for this purpose found in Practice **E2075** and Guide **E976**.

9.4 Routine verification of the system's ability to locate and cluster data should be performed monthly. With two sensors mounted on one tube and a ruler taped to the tube surface, use a pencil lead break (PLB) at 60 cm [2 ft.] intervals along the entire length of the tube (5 PLBs at each point). Examine the recorded data to verify that locations and clusters are in the correct positions.

9.5 Pre-examination and post-examination, system performance verification must be conducted immediately before, and immediately after, each examination. System performance verification uses a mechanical device to induce stress waves into the vessel wall at a specified distance from each sensor. Induced stress waves stimulate a sensor in the same way as emission from a flaw. System performance verification verifies performance of the entire system (including sensors, cables, and couplant). Procedures for system performance verification are found in Guide **E2374**.

9.5.1 The preferred technique for conducting a system performance verification is a ~~pencil lead break (PLB)~~; PLB. Lead should be broken on the vessel surface no less than ~~4 in. (10.16 cm)~~ 10 cm [4 in.] from the sensor. The 2H lead, 0.3-mm [0.012-in.] diameter, 3-mm [0.012-in.] long should be used (see Fig. 45 of Guide **E976**).

9.5.2 ~~Auto Sensor Test (AST)~~—Auto Sensor Test (AST)—An electromechanical device such as a piezoelectric pulser (and sensor which contains this function) can be used in conjunction with pencil lead break (9.4.19.5.1) as a means to assure system performance. ~~This device can be used to replace the PLB post examination, system performance verification (If AST is used in conjunction with PLB for pre-examination then AST may be used, solely, for post examination system performance verification. 9.4):~~

10. Procedure

10.1 Visually examine accessible exterior surfaces of the vessel. Note observations in examination report.

10.2 Isolate vessel to prevent contact with other vessels, hardware, and so forth. When the vessel cannot be completely isolated, indicate, in the examination report, external sources which could have produced emission.

10.3 Connect fill hose and pressure transducer. Eliminate any leaks at connections.

10.4 Mount an AE sensor at each end of each tube (see Fig. 1 for typical sensor placement). Use procedures specified in Guide E650. Sensors must be at the same angular position and should be located at each end of the vessel so that the AE system can determine axial locations of sources in as much of the vessel as possible.

NOTE 3—AE instrumentation utilizing waveform based analysis techniques may require sensor placement inboard of the tube ends to achieve optimum source location results.

10.5 Adjust signal processor settings. See Appendix X1 for example.

10.6 Perform system performance verification at each sensor (see 9.49.5). Verify that peak amplitude is greater than a specified value (see Table X1.2). Verify that the AE system displays a correct location (see Note 5) for the mechanical device that is used to produce stress waves (see 9 and Table X1.2). Prior to pressurization, verify that there is no background noise above the signal processor threshold setting.

NOTE 4—Sensors must be mounted as close to the tube end as possible to optimize linear source location accuracy (refer to Fig. 1). Mounting on the tube shoulder, close to the tube neck is acceptable.

NOTE 5—If desired location accuracy cannot be attained with sensors at two axial locations, then more sensors should be added to reduce sensor spacing.

10.7 Begin pressurizing the vessel. The pressurization rate shall be low enough that flow noise is not recorded.

10.8 Monitor the examination by observing displays that show plots of AE events versus axial location. If unusual response (in the operator's judgment) is observed, interrupt pressurization and conduct an investigation.

10.9 Store all data on mass storage media. Stop the examination when the pressure reaches 110 % of normal fill pressure or 110 % of marked service pressure (whichever is greater). The pressure shall be monitored with an accuracy of ± 2 % of the maximum examination pressure.

10.9.1 *Examples:*

10.9.1.1 A tube trailer is normally filled to a gage pressure of ~~2640 psi (18.20 MPa)~~ 18.20 MPa [2640 psi]. Pressurization shall stop at ~~2904 psi (20.02 MPa)~~ 20 MPa [2900 psi].

10.9.1.2 A gas cylinder is normally filled to a gage pressure of ~~613 psi (4.23 MPa)~~ 4.23 MPa [613 psi]. The marked service pressure is ~~2400 psi (16.55 MPa)~~ 16.55 MPa [2400 psi]. Pressurization shall stop at ~~2640 psi (18.20 MPa)~~ 18.20 MPa [2640 psi].

10.10 Perform a system performance verification at each sensor (see 9.49.5). Verify that peak amplitude is greater than a specified value (see Table X1.2).

10.11 Reduce pressure in vessel to normal fill pressure by bleeding excess gas to a receiver, or vent the vessel.

10.12 Raw AE data should be filtered to eliminate emission from nonstructural sources, for example, electronic noise.

10.13 Replay examination data. Examine the location distribution plots (AE events versus axial location) for all vessels in the examination.

10.14 Based on data replay, determine whether secondary examination (ultrasonic examination) is required. Ultrasonic examination should be performed in accordance with All locations on a pressure vessel (e.g. DOT 3AAX tube) with five or more located AE events that occurred within a 20.3 cm [8 in.] axial distance, on the cylindrical portion of a tube, must have a follow-up inspection using Practice E2223. Appendix X1 provides examples of such determinations.

11. Report

11.1 Prepare a written report from each examination. Report the following information:

11.1.1 Name of the owner of the vessel and the vehicle number (if appropriate).

11.1.2 Examination date and location.

11.1.3 Previous examination date and previous maximum pressurization. See Note 6.

NOTE 6—If the operator is aware of situations where the vessel was subject to pressures that exceeded normal fill pressure, these should be described in the report.

11.1.4 Any U.S. Department of Transportation (DOT) specification that applies to the vessel.

11.1.5 Any DOT exemption numbers that apply to the vessel.

11.1.6 Normal fill pressure and marked service pressure.

11.1.7 Pressurization medium.

11.1.8 Amplitude measurements from pre- and post-performance verification.

11.1.9 Pressure at which data acquisition commenced.

11.1.10 Maximum examination pressure.

11.1.11 Record wave velocity and threshold used in the location calculation.

11.1.12 Locations of AE sources that exceed acceptance criteria. Location shall include distance from end of vessel that bears the serial number (usually this is stamped in the vessel wall).

11.1.13 Signature of examiner.

11.1.14 Stacking chart that shows relative locations of vessels (if a multiple vessel array is tested).

11.1.15 Visual examination results.

11.1.16 AE examination results, including events versus location plots for each vessel and cumulative events versus pressure plot for each vessel.

12. Keywords

12.1 acoustic emission; flaws in steel vessels; gas pressure vessels; seamless gas cylinders; seamless steel cylinders; seamless vessels

ANNEX

(Mandatory Information)

A1. INSTRUMENTATION SPECIFICATIONS

A1.1 Sensors

A1.1.1 The AE sensors shall have high sensitivity within the frequency band of 20 to 1200 kHz bandpass of intended use. Sensors may be broad band or resonant.

A1.1.2 Sensitivity shall be greater than ~~77 dBV (referred to 1 V/ μ bar, determined by face-to-face ultrasonic examination) within the frequency range of intended use~~ than 70 dBV from a PLB source (as described in subsection 4.3.3 of Guide E976 use:).

A1.1.3 Sensitivity within the range of intended use shall not vary more than 3 dB over the intended range of temperatures in which sensors are used.

A1.1.4 Sensors shall be shielded against electromagnetic interference through proper design practice or differential (anticoincidence) element design, or both.

A1.1.5 Sensors shall be electrically isolated from conductive surfaces by means of a shoe (a wear plate).

A1.2 Signal Cable

A1.2.1 The sensor signal cable which connects sensor and preamplifier shall not reduce sensor output more than 3 dB (6 ft (1.83 m) (2 m [6.6 ft] is a typical maximum length). Integral preamplifier sensors meet this requirement. They have inherently short, internal, signal cables.

A1.2.2 Signal cable shall be shielded against electromagnetic interference. Standard coaxial cable is generally adequate.

A1.3 Couplant

A1.3.1 A couplant shall provide adequate ultrasonic coupling efficiency throughout the examination.

A1.3.2 The couplant must be temperature stable over the temperature range intended for use.

A1.3.3 Adhesives may be used if they satisfy ultrasonic coupling efficiency and temperature stability requirements.

A1.4 Preamplifier

A1.4.1 The preamplifier shall have noise level no greater than 7 μ V rms (referred to a shorted input) within the bandpass range.