



Designation: **E911 – 98 (Reapproved 2009) E911 – 98 (Reapproved 2015)**

## Standard Specification for Glass Stopcocks with Polytetrafluoroethylene (PTFE) Plugs<sup>1</sup>

This standard is issued under the fixed designation E911; the number immediately following the designation indicates the year of original adoption or, in the case of revision, the year of last revision. A number in parentheses indicates the year of last reapproval. A superscript epsilon ( $\epsilon$ ) indicates an editorial change since the last revision or reapproval.

### 1. Scope

1.1 This specification covers standard dimensional requirements for obtaining, within practical limits, interchangeability in glass stopcocks (**Note 1**) with polytetrafluoroethylene (PTFE) plugs for ordinary laboratory and industrial applications. It covers dimensional interchangeability only and does not involve design characteristics of the item except where specified, nor does it involve physical or chemical characteristics of the material used. It does not cover glass stopcocks with glass plugs (**Note 2**) or stopcocks intended for use in high-vacuum work.

NOTE 1—A stopcock is defined as consisting of a plug and barrel in assembled configuration.

NOTE 2—Glass stopcocks with glass plugs are covered by Specification **E675**.

NOTE 3—The dimensions pertaining to stopcocks were taken from the now obsolete Commercial Standard CS 21-58 of the U.S. Department of Commerce and Product Standard PS 28-70 published by the National Bureau of Standards.

NOTE 4—Although glass is the most common material for stopcocks, other materials may be used as specified. Stopcocks constructed from glass shall be in accordance with Specifications **E438** and **E671**.

### 2. Referenced Documents

#### 2.1 ASTM Standards:<sup>2</sup>

**D374 Test Methods for Thickness of Solid Electrical Insulation** (Withdrawn 2013)<sup>3</sup>

**D1457 Specification for Polytetrafluoroethylene (PTFE) Molding and Extrusion Materials** (Withdrawn 1996)<sup>3</sup>

**E438 Specification for Glasses in Laboratory Apparatus**

**E671 Specification for Maximum Permissible Thermal Residual Stress in Annealed Glass Laboratory Apparatus**

**E675 Specification for Interchangeable Taper-Ground Stopcocks And Stoppers**

**E920 Specification for Commercially Packaged Laboratory Apparatus**

**E921 Specification for Export Packaged Laboratory Apparatus**

**E1133 Practice for Performance Testing of Packaged Laboratory Apparatus for United States Government Procurements**

**E1157 Specification for Sampling and Testing of Reusable Laboratory Glassware**

#### 2.2 Other Standard:<sup>4</sup>

**PS 28-70 Glass Stopcocks With Polytetrafluoroethylene (PTFE) Plugs**

### 3. Material

3.1 The PTFE material used to manufacture the plugs shall be in accordance with the requirements of Specification **D1457** Types I and IV, extrusion and molding grade resins.

### 4. Requirements for Single Straight-Bore Stopcocks

4.1 The designations and dimensions for single straight-bore stopcocks are shown in **Fig. 1** and **Table 1**.

4.2 **Taper (Note 3)**—All straight-bore stopcocks shall have a taper of  $2 \pm 0.006$  mm of diameter per 10 mm of length (1 to 5).

NOTE 5—The lines of contact of the mating surfaces should form a conical section having a taper of  $2 \pm 0.006$  mm per 1 cm of axial length (before compression of the plug surface) for an axial distance of at least 10 mm on each side of the bore.

<sup>1</sup> This specification is under the jurisdiction of ASTM Committee **E41** on Laboratory Apparatus and is the direct responsibility of Subcommittee **E41.01** on Apparatus Laboratory Ware and Supplies.

Current edition approved Nov. 1, 2009; June 1, 2015. Published February 2010; July 2015. Originally approved in 1982. Last previous edition approved in 2004 (2009) as E911 – 98 (2004) (2009). DOI: 10.1520/E0911-98R09-10.1520/E0911-98R15.

<sup>2</sup> For referenced ASTM standards, visit the ASTM website, [www.astm.org](http://www.astm.org), or contact ASTM Customer Service at [service@astm.org](mailto:service@astm.org). For *Annual Book of ASTM Standards* volume information, refer to the standard's Document Summary page on the ASTM website.

<sup>3</sup> The last approved version of this historical standard is referenced on [www.astm.org](http://www.astm.org).

<sup>4</sup> Commercial Standards and Product Standards are available from National Institute of Standards and Technology (NIST), 100 Bureau Dr., Stop 1070, Gaithersburg, MD 20899-1070, <http://www.nist.gov>.

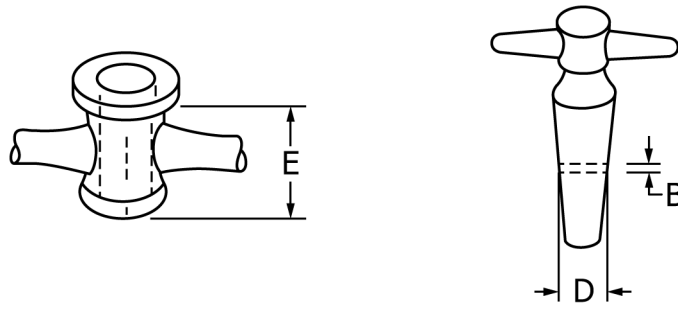

FIG. 1 Stopcock

TABLE 1 Single Straight-Bore Stopcocks

| Stopcock Designation and Bore of Hole in Plug <i>B</i> , mm | Diameter of Plug at Centerline of Bore <i>D</i> , mm | Length of Shell <i>E</i> , mm |
|---|--|-------------------------------|
| 1   | 11 ± 0.06  | 25 ± 0.5                      |
| 2   | 11 ± 0.06  | 25 ± 0.5                      |
| 3   | 15.2 ± 0.10  | 30 ± 0.5                      |
| 4   | 15.2 ± 0.10  | 30 ± 0.5                      |
| 6   | 16 ± 0.20  | 35 ± 0.5                      |

### 5. Requirements for Single Oblique-Bore Stopcocks

5.1 The designations and dimensions for single oblique-bore stopcocks are shown in Fig. 2 and Table 2.

5.2 *Taper* (Note 4)—All single oblique-bore stopcocks shall have a taper of  $2 \pm 0.006$  mm of diameter per 10 mm of length (1 to 5).

### 6. Requirements for Double Oblique-Bore (3-Way) Stopcocks

6.1 The designations and dimensions for double-oblique-bore stopcocks are shown in Fig. 3 and Table 3.

6.2 *Taper* (Note 3)—All double oblique-bore (3-way) stopcocks shall have a taper of  $2 \pm 0.006$  mm of diameter per 10 mm of length (1 to 5).

### 7. Requirements for T-Bore and 120° Bore Stopcocks

7.1 These stopcocks are designated by the nominal bore size. With the exception of the bore sizes, the dimensions and tolerances for 1 and 2-mm T-bore and 120° bore stopcocks are the same as for the 4-mm single straight-bore stopcocks. Dimensions and tolerances for 3 and 4-mm T-bore and 120° bore stopcocks are the same as for the 6-mm single-bore stopcocks (see Table 1).

7.2 *Taper* (Note 3)—All T-bore and 120° bore stopcocks shall have a taper of  $2 \pm 0.006$  mm of diameter per 10 mm of length (1 to 5).

### 8. Test Methods

8.1 *Dimensions*—Determine dimensions in accordance with Method B of Test Methods D374, except that micrometre calipers graduated to 0.01 mm shall be used.

8.2 *Taper*—Measure taper by using a sine bar and plate or an air gage.

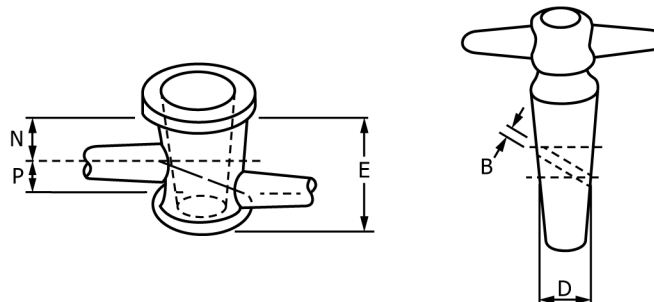

FIG. 2 Single Oblique-Bore Stopcock