



Designation: **D5977–03 (Reapproved 2012) D5977 – 15**

Standard Specification for High Load Rotational Spherical Bearings for Bridges and Structures¹

This standard is issued under the fixed designation D5977; the number immediately following the designation indicates the year of original adoption or, in the case of revision, the year of last revision. A number in parentheses indicates the year of last reapproval. A superscript epsilon (ϵ) indicates an editorial change since the last revision or reapproval.

1. Scope

1.1 This specification covers bridge bearings that consist of a spherical rotational element, where a stainless steel convex surface slides against a concave carbon steel plate covered with woven or sheet polytetrafluoroethylene (PTFE). The function of the bearing is to transfer loads and to accommodate any relative movement, including rotation between a bridge superstructure and its supporting structure, or both.

1.2 This specification covers the requirements of spherical bearings with a standard horizontal load (a maximum of 10 % of vertical).

1.3 The requirements stated in this specification are the minima necessary for the manufacture of quality bearing devices. It may be necessary to increase these minimum values due to other design conditions.

1.4 The values stated in inch-pound units are to be regarded as the standard. The values given in parentheses are for information only.

1.5 The following safety hazards caveat pertains only to the test method portion, Section 7, of this specification: *This standard does not purport to address all of the safety concerns, if any, associated with its use. It is the responsibility of the user of this standard to establish appropriate safety and health practices and determine the applicability of regulatory limitations prior to use.*

2. Referenced Documents

2.1 ASTM Standards:²

[A36/A36M Specification for Carbon Structural Steel](#)

[A167 Specification for Stainless and Heat-Resisting Chromium-Nickel Steel Plate, Sheet, and Strip \(Withdrawn 2014\)³](#)

[A240/A240M Specification for Chromium and Chromium-Nickel Stainless Steel Plate, Sheet, and Strip for Pressure Vessels and for General Applications](#)

[A572/A572M Specification for High-Strength Low-Alloy Columbium-Vanadium Structural Steel](#)

[A588/A588M Specification for High-Strength Low-Alloy Structural Steel, up to 50 ksi \[345 MPa\] Minimum Yield Point, with Atmospheric Corrosion Resistance](#)

[A709/A709M Specification for Structural Steel for Bridges](#)

[D638 Test Method for Tensile Properties of Plastics](#)

[D792 Test Methods for Density and Specific Gravity \(Relative Density\) of Plastics by Displacement](#)

[D1457 Specification for Polytetrafluoroethylene \(PTFE\) Molding and Extrusion Materials \(Withdrawn 1996\)³](#)

[D1777 Test Method for Thickness of Textile Materials](#)

[D2256 Test Method for Tensile Properties of Yarns by the Single-Strand Method](#)

2.2 AASHTO Standard:⁴

[AASHTO Standard Specifications for Highway Bridges](#)

¹ This specification is under the jurisdiction of ASTM Committee D04 on Road and Paving Materials and is the direct responsibility of Subcommittee D04.32 on Bridges and Structures.

Current edition approved July 15, 2012; June 1, 2015. Published July 2012; July 2015. Originally approved in 1996. Last previous edition approved in 2007 as D5977 – 03 (2012), (2007); DOI: 10.1520/D5977-03R12-10.1520/D5977-15.

² For referenced ASTM standards, visit the ASTM website, www.astm.org, or contact ASTM Customer Service at service@astm.org. For *Annual Book of ASTM Standards* volume information, refer to the standard's Document Summary page on the ASTM website.

³ The last approved version of this historical standard is referenced on www.astm.org.

⁴ Available from American Association of State Highway and Transportation Officials (AASHTO), 444 N. Capitol St., NW, Suite 249, Washington, DC 20001, <http://www.transportation.org>.

2.3 AWS Standards:⁵

[C.2.2-67 Metalizing with Aluminum and Zinc for Protection of Iron and Steel](#)

[D.1.5 ANSI/AASHTO/AWS Bridge Welding Code](#)

3. Classification

3.1 The bearings are furnished in three types, as follows:

3.1.1 *Fixed Spherical Bearing*—Rotation only.

3.1.2 *Uni-Directional Sliding Spherical Bearing*—Rotation plus movement in one direction.

3.1.3 *Multi-Directional Sliding Spherical Bearing*—Rotation plus movement in all directions.

4. Material Specifications

4.1 *Steel*—The steel used for all major plates shall be structural steel conforming to Specifications [A36/A36M](#), [A588/A588M](#), [A572/A572M](#), or [A709/A709M](#), as required. All exposed surfaces shall be zinc metalized according to AWS C.2.2-67 (with no chipping), having a minimum thickness of 6 mil (0.152 mm) or treated with other project-approved coating systems such as coal tar or inorganic zinc paint. The dry film thickness (DFT) of the approved paint system must be specified by the owner.

4.2 *Stainless Steel*:

4.2.1 *Flat Sliding Surface*—The sheet stainless steel used as the mating sliding surface to the woven fabric PTFE or sheet PTFE in the sliding spherical bearings shall conform to Specification [A167](#) or [A240/A240M](#), type 304, 20- μ in. (0.5- μ m) rms finish.

4.2.2 *Convex Surface*—The solid stainless steel plate or sheet stainless steel used as the mating rotational convex surface to the woven fabric PTFE or sheet PTFE shall conform to Specification [A167](#) or [A240/A240M](#), type 304. The surface shall be machined to a surface finish of 20- μ in. (0.5- μ m) rms or less.

4.3 *Woven Fabric Polytetrafluoroethylene (PTFE)*—The woven fabric PTFE shall be made from virgin PTFE oriented multifilament fibers with or without a high-strength backing.

4.3.1 The thickness of the woven fabric PTFE in the free state shall be a minimum of $\frac{3}{32}$ in. (2.38 mm) when measured in accordance with Method [D1777](#).

4.3.2 The thickness of the bonded woven fabric PTFE under the application of vertical load (excluding any backing material) shall be a minimum of the following:

(1) $\frac{1}{16}$ in. (1.59 mm) from 0 psi (0 N/mm²) to 3500 psi (24.1 N/mm²).

(2) $\frac{3}{64}$ in. (1.19 mm) from 3501 psi (24.1 N/mm²) to 4500 psi (31.0 N/mm²).

4.3.3 The woven fabric PTFE shall be mechanically interlocked and epoxy-bonded to the substrate using a system that prevents migration of the epoxy through the fabric. The use of a mechanical interlock system along with the epoxy increases the bond strength, providing a redundancy for the prevention of migration of the PTFE material. Any edges, other than the selvage (woven edge), shall be oversewn so that no cut fabric edges are exposed.

4.3.4 The individual PTFE filaments used in making the woven PTFE fabric shall conform to the physical requirements of [Table 1](#).

4.4 *Sheet Polytetrafluoroethylene (PTFE)*—The sheet PTFE shall be virgin material (not reprocessed) meeting the requirements of Specification [D1457](#). The PTFE shall be resistant to acids, alkalis, petroleum products, and nonabsorption of water. It shall be stable for temperatures up to 500°F (260°C) and shall be nonflammable. When used in PTFE surfaces used for guide bars only, filler material shall be composed of milled glass fibers or carbon.

4.4.1 The thickness of the sheet PTFE shall be a minimum of $\frac{1}{8}$ in. (3.17 mm) and shall be recessed at least one-half of its thickness.

4.4.2 The PTFE for the principal slide surface and for guide bars shall conform to the physical requirements listed in [Table 2](#).

5. Design Requirements

NOTE 1—*To Designer*: The bearing details shall be designed in accordance with the requirements of the current edition with interims of the AASHTO Standard Specifications for Highway Bridges or other governing design procedures.

⁵ Available from American Welding Society (AWS), 550 NW LeJeune Rd., Miami, FL 33126, <http://www.aws.org>.

TABLE 1 Physical Property Requirements for Woven PTFE

Physical Properties	Test Method	Requirement
Ultimate tensile strength, min, psi (MPa)	D2256	—24 000 (165.4)
Ultimate elongation, min, %	D2256	—35

TABLE 1 Physical Property Requirements for Woven PTFE

Physical Properties	Test Method	Requirement
Ultimate tensile strength, min, psi (MPa)	D2256	24 000 (165.4)
Ultimate elongation, min, %	D2256	>10 % ≤ 35 %

TABLE 2 Physical Property Requirements for Sheet PTFE^A

Physical Properties	Test Method	Requirement
Ultimate tensile strength, min, psi (MPa)	D638	2800 (19.3)
Ultimate elongation, min, %	D638	200
Specific gravity, min	D792	2.12

^A15 % glass-filled PTFE may be used for guide bar surfaces (Specification D1457).

5.1 Rotational Elements:

5.1.1 The spherical radius shall be determined such that the resulting geometry of the bearing is capable of withstanding the greatest ratio of the horizontal load to vertical load under all loading conditions to prevent the unseating (separation at the edges) of the convex/concave elements.

5.1.2 Unseating of the curved spherical surfaces relative to each other shall be prevented by transferring horizontal forces through specifically designed restraints or by control of the spherical radius.

5.1.3 Acceptable spherical radius control shall be given when the configuration of the woven fabric PTFE concave radius follows the following design:

$$\text{ratio} \leq \tan \alpha \tag{1}$$

where:

ratio = worst case ratio of horizontal to vertical loads.

$$\alpha = \left(\arcsin \left(\frac{d/2}{R_{\max}} \right) \right) - (\text{design rotation}) \tag{2}$$

where:

- d* = projected diameter of the woven fabric PTFE,
- design rotation = design rotation of the bearing (in degrees), and
- R_{max}* = maximum allowable radius to prevent uplift within the bearing during the worst horizontal to vertical load case.

5.1.4 Calculations showing determination of the radius shall be submitted for approval.

5.1.5 The radius of the convex plate shall be less than the radius calculated for the woven fabric PTFE (concave plate) by a value equal to the thickness of the PTFE.

5.1.6 The concave surface shall face down whenever the resulting center of rotation is not detrimental to the system geometry. See Fig. 1

5.1.7 The minimum thickness at the center of the concave spherical element shall be 3/4 in. (19 mm).

5.1.8 The minimum thickness at the edge of the convex spherical element shall be 1/2 in. (12.7 mm).

5.1.9 Vertical and horizontal clearance between the rotating (attached to the superstructure) and non-rotating (attached to the substructure) spherical bearing components, including fasteners, shall be no less than 1/8 in. (3.17 mm) when rotated to 150 % of the design rotation.

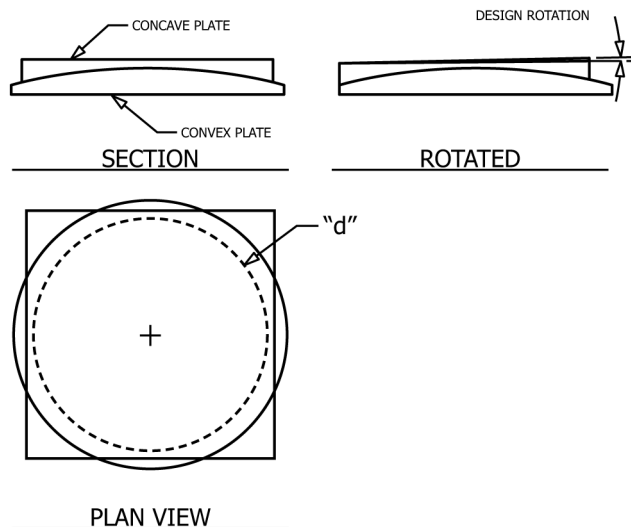

FIG. 1 Views of a Spherical Bearing