



Designation: **D5856 – 95 (Reapproved 2007) D5856 – 15**

Standard Test Method for Measurement of Hydraulic Conductivity of Porous Material Using a Rigid-Wall, Compaction-Mold Permeameter¹

This standard is issued under the fixed designation D5856; the number immediately following the designation indicates the year of original adoption or, in the case of revision, the year of last revision. A number in parentheses indicates the year of last reapproval. A superscript epsilon (ϵ) indicates an editorial change since the last revision or reapproval.

1. Scope

1.1 This test method covers laboratory measurement of the hydraulic conductivity (also referred to as *coefficient of permeability*) of laboratory-compacted materials with a rigid-wall, compaction-mold permeameter.

1.2 This test method may be used with laboratory-compacted specimens that have a hydraulic conductivity less than or equal to 1×10^{-5} m/s. The hydraulic conductivity of compacted materials that have hydraulic conductivities greater than 1×10^{-5} m/s may be determined by Test Method [D2434](#).

1.3 Units—The values stated in SI units are to be regarded as the standard, unless other units are specifically given. By tradition in U.S. practice, hydraulic conductivity is reported in ~~centimetres per second, cm/s,~~ although the common SI units for hydraulic conductivity are ~~metres per second, m/s.~~

1.4 *This standard does not purport to address all of the safety concerns, if any, associated with its use. It is the responsibility of the user of this standard to establish appropriate safety and health practices and determine the applicability of regulatory limitations prior to use.*

2. Referenced Documents

2.1 ASTM Standards:²

[D653 Terminology Relating to Soil, Rock, and Contained Fluids](#)

[D698 Test Methods for Laboratory Compaction Characteristics of Soil Using Standard Effort \(12 400 ft-lbf/ft³ \(600 kN-m/m³\)\)](#)

[D854 Test Methods for Specific Gravity of Soil Solids by Water Pycnometer](#)

[D1557 Test Methods for Laboratory Compaction Characteristics of Soil Using Modified Effort \(56,000 ft-lbf/ft³ \(2,700 kN-m/m³\)\)](#)

[D2216 Test Methods for Laboratory Determination of Water \(Moisture\) Content of Soil and Rock by Mass](#)

[D2434 Test Method for Permeability of Granular Soils \(Constant Head\) \(Withdrawn 2015\)³](#)

[D3740 Practice for Minimum Requirements for Agencies Engaged in Testing and/or Inspection of Soil and Rock as Used in Engineering Design and Construction](#)

[D4753 Guide for Evaluating, Selecting, and Specifying Balances and Standard Masses for Use in Soil, Rock, and Construction Materials Testing](#)

[D5084 Test Methods for Measurement of Hydraulic Conductivity of Saturated Porous Materials Using a Flexible Wall Permeameter](#)

[E145 Specification for Gravity-Convection and Forced-Ventilation Ovens](#)

3. Terminology

3.1 *Definitions of Terms Specific to This Standard: Definitions:*

3.1.1 *flux*—quantity of flow per unit area per unit time.

3.1.1 *hydraulic conductivity, k*—the rate of discharge of water under laminar flow conditions through a unit cross-sectional area of a porous medium under a unit hydraulic gradient and standard temperature conditions (20°C).

¹ This test method is under the jurisdiction of ASTM Committee [D18](#) on Soil and Rock and is the direct responsibility of Subcommittee [D18.04](#) on Hydrologic Properties and Hydraulic Barriers.

Current edition approved ~~May 1, 2007~~ June 1, 2015. Published ~~July 2007~~ July 2015. Originally approved in 1995. Last previous edition approved in ~~2002~~ 2007 as [D5856-95\(2002\)](#) [D5856-95\(2007\)](#).¹ DOI: [10.1520/D5856-95R07-10.1520/D5856-15](#).

² For referenced ASTM standards, visit the ASTM website, [www.astm.org](#), or contact ASTM Customer Service at [service@astm.org](#). For *Annual Book of ASTM Standards* volume information, refer to the standard's Document Summary page on the ASTM website.

³ The last approved version of this historical standard is referenced on [www.astm.org](#).

3.1.1.1 Discussion—

The term *coefficient of permeability* is often used instead of *hydraulic conductivity*, *conductivity*, but *hydraulic conductivity* is used exclusively in this test method. A more complete discussion of the terminology associated with Darcy's law is given in the literature⁴.

~~3.1.3 pore volume of flow—the cumulative quantity of outflow from a test specimen divided by the volume of pore space in the specimen.~~

3.1.2 For common definitions of ~~other technical~~ terms used in this test method see standard, refer to Terminology D653.

3.2 Definitions of Terms Specific to This Standard:

3.2.1 flux—quantity of flow per unit area per unit time.

3.2.2 pore volume of flow—the cumulative quantity of outflow from a test specimen divided by the volume of pore space in the specimen.

4. Significance and Use

4.1 This test method applies to one-dimensional, laminar flow of water within laboratory-compacted, porous materials such as soil.

4.2 The hydraulic conductivity of porous materials generally decreases with an increasing amount of air in the pores of the material. This test method applies to porous materials containing little or no air. The test method is designed to minimize the amount of air in the test specimen. However, this test method does not ensure complete saturation of the test specimen with water. In cases where it is essential to saturate the test specimen fully with water, the compacted specimen may be tested using Test Method **D5084**.

4.3 This test method applies to permeation of porous materials with water. Permeation with other liquids, such as chemical wastes, can be accomplished using procedures similar to those described in this test method. However, this test method is only intended to be used when water is the permeant liquid.

4.4 It is assumed that Darcy's law is valid and that the hydraulic conductivity is essentially unaffected by hydraulic gradient. The validity of ~~Darcy's~~Darcy's law may be evaluated by measuring the hydraulic conductivity of the specimen at three hydraulic gradients; if all measured values are similar (within 25 %), then ~~Darcy's~~Darcy's law may be taken as valid. However, when the hydraulic gradient acting on a test specimen is changed, the state of stress will also change, and, if the specimen or pore fluid is compressible, the volume of the test specimen or pore fluid will change. Thus, some change in hydraulic conductivity may occur when the hydraulic gradient is altered, even in cases where ~~Darcy's~~Darcy's law is valid.

4.5 One potential problem with this method of testing is the possibility that water will flow along the interface between the test specimen and the compaction/permeameter ring. The problem tends to be of minimal significance for materials that swell when exposed to water (for example, compacted, clayey soils) but can be a very serious problem for materials that might tend to shrink and pull away from the walls of the permeameter. Test Method **D5084** is recommended for any material that tends to shrink when exposed to the permeant liquid.

4.6 The correlation between results obtained with this test method and the hydraulic conductivities of in-place, compacted materials has not been fully investigated. Experience has sometimes shown that flow patterns in small, laboratory-prepared test specimens do not necessarily follow the same patterns on large field scales and that hydraulic conductivities measured on small test specimens are not necessarily the same as larger-scale values. Therefore, the results should be applied to field situations with caution and by qualified personnel.

NOTE 1—The quality of the result produced by this standard is dependent on the competence of the personnel performing it, and the suitability of the equipment and facilities used. Agencies that meet the criteria of Practice **D3740** are generally considered capable of competent and objective testing/sampling/inspection/etc. Users of this standard are cautioned that compliance with Practice **D3740** does not in itself ensure reliable results. Reliable results depend on many factors; Practice **D3740** provides a means of evaluating some of those factors.

5. Apparatus

5.1 *Hydraulic System*—Constant head (Test Method A), falling head (Test Methods B, C, and D), or constant rate of flow (Test Method E) systems may be used provided they meet the criteria outlined as follows:

5.1.1 *Constant Head*—The system must be capable of maintaining a constant hydraulic pressure or head to within $\pm 5\%$ ~~$\pm 5\%$~~ and shall include means to measure hydraulic pressures or heads to within the prescribed tolerance. In addition, the head loss across the test specimen must be held constant to within $\pm 5\%$ ~~$\pm 5\%$~~ and shall be measured with the same accuracy or better. Pressures shall be measured by a pressure ~~gage,~~gauge, electronic pressure transducer, or any other device of suitable accuracy. Head of liquid in a standpipe may be measured with a graduated ~~pipette,~~pipet, ruler, scale, or other device of suitable accuracy.

⁴ Olson, R. E., and Daniel, D. E., "Measurement of the Hydraulic Conductivity of Fine-Grained Soils," *Symposium on Permeability and Groundwater Contaminant Transport, ASTM STP 746*, ASTM, 1981, pp. 18–64.

5.1.2 *Falling Head*—The system shall allow for measurement of the applied head loss, thus hydraulic gradient, to ~~within~~ $\pm 5\%$ ~~within~~ $\pm 5\%$ or better at any time. In addition, the ratio of initial head loss divided by final head loss over an interval of time shall be measured such that this computed ratio is accurate to ~~within~~ $\pm 5\%$ ~~within~~ $\pm 5\%$. The head loss shall be measured with a pressure ~~gage, gauge,~~ electronic pressure transducer, ~~engineer's~~ ~~engineer's~~ scale, graduated ~~pipette, pipet,~~ or any other device of suitable accuracy. Falling head tests may be performed with either a constant tailwater elevation (Test Method B), rising tailwater elevation (Test Method C), or increasing tailwater elevation (Test Method D).

5.1.3 *Constant Rate of Flow*—The system must be capable of maintaining a constant rate of flow through the specimen to within $\pm 5\%$ ~~within~~ $\pm 5\%$ or better. Flow measurement or control shall be by calibrated syringe, graduated ~~pipette, pipet,~~ or other device of suitable accuracy. The head loss across the specimen shall be measured to an accuracy of $\pm 5\%$ ~~within~~ $\pm 5\%$ or better using an electronic pressure transducer or other device of suitable accuracy. A means to ensure that the head being measured is not affected by sidewall leakage should be included. More information on testing with a constant rate of flow is given in the literature⁵.

5.2 *Flow Measurement System*—Both inflow and outflow volumes shall be measured or controlled. Flow volumes shall be measured by a graduated accumulator, graduated ~~pipette, pipet,~~ graduated cylinder, vertical standpipe in conjunction with an electronic pressure transducer, marriotte bottle, or other volume-measuring device of suitable accuracy. For long-term tests, evaporative losses may be significant and should be accounted for using a suitable correction procedure.

5.2.1 *Flow Accuracy*—Required accuracy for the quantity of flow measured over an interval of time is $\pm 5\%$ ~~within~~ $\pm 5\%$ or better.

5.2.2 *Head Losses*—Head losses in the tubes, valves, porous end pieces, and filter paper may lead to error. To guard against such errors, the permeameter shall be assembled with no specimen inside (but with any porous end pieces or sheets of filter paper that will be used) and then the hydraulic system filled. If a constant or falling head test is to be used, the hydraulic pressures or heads that will be used in testing a specimen shall be applied, and the rate of flow measured with an accuracy of $\pm 5\%$ ~~within~~ $\pm 5\%$ or better. This rate of flow shall be at least ten times greater than the rate of flow that is measured when a specimen has been compacted inside the permeameter and the same hydraulic pressures or heads are applied. If a constant rate of flow test is to be used, the rate of flow to be used in testing a specimen shall be supplied to the permeameter and the head loss measured. The head loss without a specimen shall be less than 0.1 times the head loss when a specimen is present.

5.3 *Permeameter Cell*—The permeameter cell shall consist of a rigid-wall compaction mold into which the material to be tested is compacted and in which the compacted material is permeated; and two end plates to control flow into and out of the test specimen. A swell ring may be provided as discussed in 5.3.2. The permeameter shall be designed and operated so that permeant water flows downward through the test specimen, although upward flow may be used if the top of the specimen is protected from upward movement by a rigid porous element.

5.3.1 *Compaction Mold/Permeameter Ring*—The compaction mold/permeameter ring shall be constructed of a rigid material that will not be damaged during compaction of the test specimen and that will not undergo adverse chemical reactions with the test material or permeant water. Materials such as steel, aluminum, brass, plastic, and glass have been used. The mold shall be sufficiently rigid so that its expansion when the permeameter is pressurized is negligibly small. The mold can be any cylindrical shape so long as: the cross-sectional area along the direction of flow does not vary by more than $\pm 2\%$; $\pm 2\%$; height and diameter are each ≥ 25 – ≥ 25 mm; height does not vary by more than $\pm 1\%$; $\pm 1\%$, and the largest particle and clod size in the compacted specimen is $\leq 1/6$ the lesser of the height or diameter.

5.3.2 *Swell Ring*—The top of the permeameter may be designed to function in one of three ways: (1) to allow no restraint against swelling (see Fig. 1), in which case a swell ring separates the compaction mold/permeameter ring from the top plate; (2) to allow no swelling of the test specimen (see Fig. 2), in which case no swell ring is provided; or (3) to control the vertical stress that is applied to the test specimen (see Fig. 3), in which case a swell ring may or may not be needed, depending upon how the top plate is designed and how the vertical stress is applied. If a swell ring is used, it shall be constructed of a rigid material that will not react adversely with the test material or permeant water, shall have the same diameter or width as the compaction mold/permeameter ring, and shall be sufficiently high to allow free swelling of the test specimen or to accommodate stress-control apparatus. Sand may be placed in the swell ring to minimize erosion of the specimen from influent flow provided that the sand is included in the measurement of head losses in the permeameter (see 5.2.2).

5.3.3 *Stress-Control Apparatus*—If the upper surface of the compacted test specimen is subjected to a controlled vertical stress, the stress shall be applied through a rigid plate using any means that maintains the stress within $\pm 5\%$ ~~within~~ $\pm 5\%$ of the desired value.

5.3.4 *Bottom Plate*—The bottom plate shall be constructed of rigid material that does not react adversely with the test material or permeant liquid. The plate shall serve the purpose of preventing the test specimen from swelling downward, supporting the test specimen, collecting effluent liquid from the base of the test specimen, and ensuring one-dimensional flow near the effluent end of the test specimen. The base plate shall be sealed to the compaction mold/permeameter ring, for example, with an O-ring, to prevent leakage. Checks for leaks, conducted without soil in the cell, are helpful to ensure adequacy of the seals. Careful examination of the seal is particularly important when the apparatus is disassembled and re-assembled during the test. The bottom plate shall contain a porous material (such as porous plastic, porous metal, porous corundum, or well-compacted sand) that is far

⁵ Olsen, H. W., Gill, J. D., Willden, A. T., and Nelson, N. R., "Innovations in Hydraulic Conductivity Measurements," *Transportation Research Record No. 1309*, Transportation Research Board, National Research Council, Washington, DC, 1991.

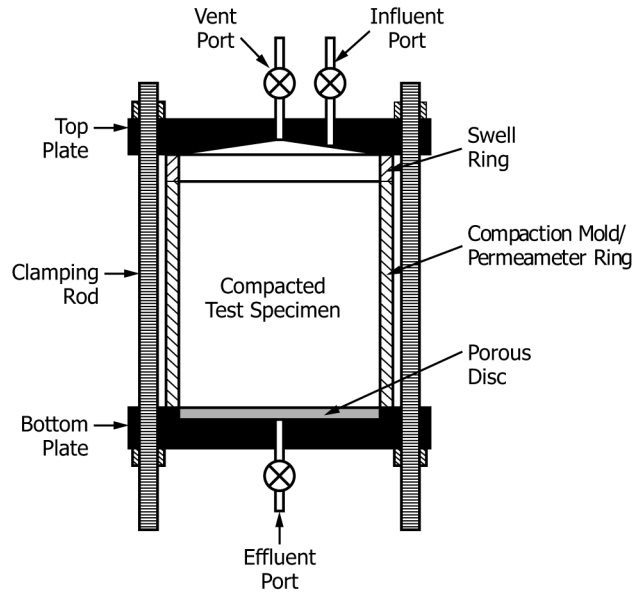

FIG. 1 Compaction-Mold Permeameter with No Restraint Against Swelling at Top of Test Specimen

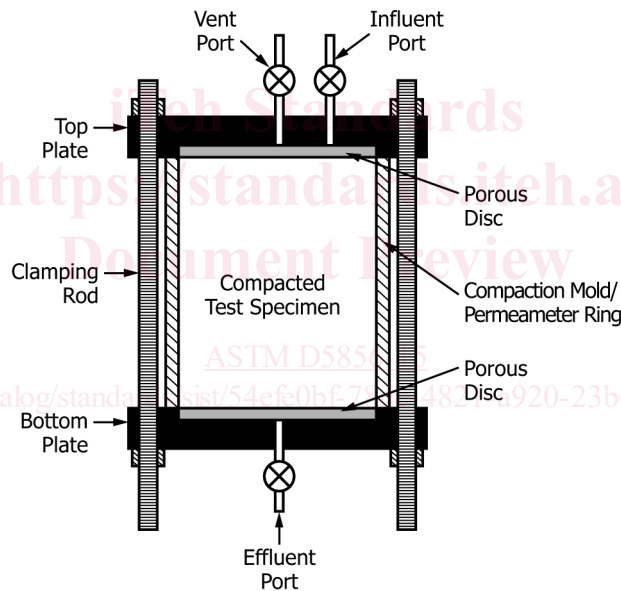

FIG. 2 Compaction-Mold Permeameter in Which Test Specimen Cannot Swell

more permeable than the test specimen (5.2.2 ensures that this is the case) and that has the same overall diameter or width as the test specimen. Two base plate designs are acceptable:

5.3.4.1 *Single-Ring*—This design (Fig. 1, Fig. 2, and Fig. 3) consists of a single porous material with the same diameter or width as the test specimen.

5.3.4.2 *Double Ring*—With this design (see Fig. 4), outflow from the central part of the test specimen is separated from flow near the sidewalls in the base plate. The system shall be designed so that the collector ring (see Fig. 4) protrudes approximately 3 mm into the test specimen and completely separates flow entering the base plate through the inner zone from flow entering the outer zone. A thin ring with a sharp edge should be used to prevent disturbance of the soil during installation.

NOTE 2—The double ring is preferred over the single ring because the double ring provides a means for identifying erroneous measurements caused by side-wall leakage. Unless the requestor specifically requests a single-ring base plate, the double-ring base plate shall be used.

5.3.5 *Top Plate*—The top plate shall be constructed from rigid materials that do not react adversely with the test material or permeant water. The top plate shall be sealed to the compaction mold/permeameter ring or swell ring (if present) in a way that prevents leakage. Tests for leaks, conducted without soil in the cell, are helpful to ensure the adequacy of the seals. The plate shall be designed to ensure that flow through the test specimen is one-dimensional.

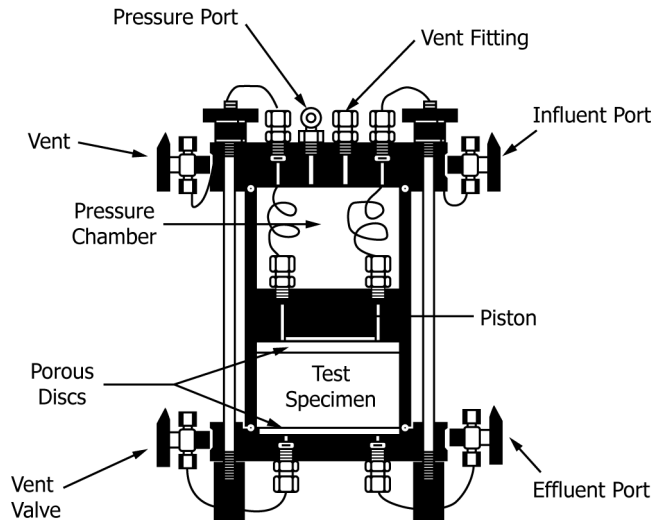

FIG. 3 Compaction-Mold Permeameter With a Controlled Vertical Stress Applied to the Top of the Test Specimen

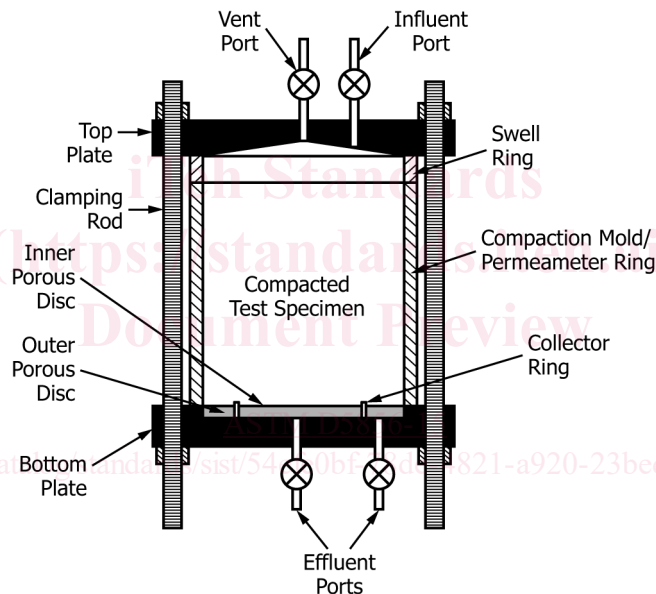

FIG. 4 Compaction-Mold Permeameter With a Double Ring in Base Plate

5.4 *Filter Paper*—If necessary to prevent intrusion of material into the pores of the porous end pieces, one or more sheets of filter paper shall be placed between the top and bottom porous end pieces and the specimen. The paper shall have a negligibly small hydraulic impedance. The requirements outlined in 5.2.2 ensure that the impedance is small.

5.5 *Equipment for Compacting a Specimen*—Equipment (including compactor and mold) suitable for the method of compaction specified by the requester shall be used. Examples of compaction equipment/procedures are Test Methods D698 and D1557.

5.6 *Devices for Measuring the Dimensions of the Specimen*—Devices used to measure the dimensions of the specimen shall be capable of measuring to the nearest 0.3 mm (0.01 in.) or better and shall be constructed such that their use will not disturb the specimen.

5.7 *Balances*—The balance shall be suitable for determining the mass of the specimen and shall be selected as discussed in Specification D4753. The mass of specimens less than 100 g shall be determined to the nearest 0.01 g. The mass of specimens 100 g or larger shall be determined to the nearest 0.1 g. The mass of specimens >1000 g shall be determined to the nearest 1.0 g.

5.8 *Temperature Maintaining Device*—The temperature of the permeameter, test specimen, and reservoir of permeant liquid shall not vary more than $\pm 3^{\circ}\text{C}$ ($\pm 5.7^{\circ}\text{F}$). Normally, this is accomplished by performing the test in a room with a relatively constant temperature. If such a room is not available, the apparatus shall be placed in a water bath, insulated chamber, or other device that maintains a temperature within the tolerance specified above. The temperature shall be periodically measured and recorded.

5.9 *Water Content Containers*—The containers shall be in accordance with Test Method **D2216**.

5.10 *Drying Oven*—The oven shall be in accordance with Specification **E145**.

6. Reagents

6.1 Permeant Water:

6.1.1 The permeant water is the liquid used to permeate the test specimen. Any liquid introduced into the test specimen, porous elements, filter paper, or other portions of the permeameter shall be permeant water.

6.1.2 The type of permeant water shall be specified by the requestor. If no specification is made, de-aired tap water shall be used for the permeant liquid. The type of water used shall be indicated in the report. Regardless of the type of permeant water requested, the water shall be de-aired water (see **6.1.3**), unless the requestor specifically requests that the water not be de-aired.

NOTE 3—Chemical interactions between a permeant liquid and the porous material may lead to variations in hydraulic conductivity. Distilled water can significantly lower the hydraulic conductivity of clayey soils.⁴ For this reason, distilled water is not usually recommended as a permeant liquid. A permeant liquid used by some is 0.005 *N* CaSO₄, that can be obtained, for example, by dissolving 6.8 g of non-hydrated, reagent-grade CaSO₄ in 10 L of de-aired, distilled (or de-ionized) water. This CaSO₄ solution is thought to neither increase nor decrease significantly the hydraulic conductivity of clayey soils. In areas with extremely brackish tap water, the CaSO₄ solution is recommended.

6.1.3 To aid in removing as much air from the test specimen as possible, de-aired water shall be used. The water is usually de-aired by boiling, by spraying a fine mist of water into an evacuated vessel attached to a vacuum source, or by forceful agitation of water in a container attached to a vacuum source. If boiling is used, care shall be taken not to evaporate an excessive amount of water, which can lead to a larger salt concentration in the permeant water than desired. To prevent dissolution of air back into the water, de-aired water shall not be exposed to air for prolonged periods.

7. Test Specimen

7.1 *Preparation of Compaction/Permeameter Ring*—Prior to compaction, determine the inside dimensions of the compaction/permeameter ring to the tolerances given in **5.3.1**, and determine the mass of the compaction/permeameter ring to the tolerances given in **5.7**. If desired, the inside of the permeameter may be coated with a thin layer of sodium bentonite paste to minimize the possibility of side-wall leakage.

7.2 *Compaction*—Prepare the material to be tested and compacted inside the compaction/permeameter ring in a manner specified by the requestor. If the specimen is placed and compacted in layers, lightly scarify the surface of each previously compacted layer (roughen) with a fork, ice pick, or other suitable object, unless the requestor specifically states that scarification is not to be performed. Test Methods **D698** and **D1557** describe two methods of compaction, but any other method specified by the requestor may be used as long as the method is described in the report. Large clods of material should not be broken down prior to compaction unless it is known that they will be broken in field construction, as well, or the requestor specifically requests that the clod size be reduced. Neither hard clods nor individual particles of the material shall exceed 1/6 of either the height or diameter of the specimen. After compaction, determine the mass of the compaction/permeameter ring containing the compacted specimen and immediately mount the compaction/permeameter ring containing the test specimen in the permeameter. Determine the water content of the trimmings or excess material in accordance with Test Method **D2216**. Determine the mass (*M*) of the test specimen by subtracting the mass of the compaction/permeameter ring from the mass of the compaction/permeameter ring plus test specimen.

7.3 Calculate the total volume of the test specimen (*V*) from the length (*L*) and diameter (*D*) of the test specimen as follows:

$$V = \frac{\pi D^2 L}{4} \quad (1)$$

7.4 Calculate the initial dry density (ρ_{di}) of the compacted specimen and porosity (*n*) of the test specimen from the mass (*M*) and volume of the specimen (*V*) and from the approximate water content (*w*, in decimal form) of the specimen as follows:

$$\rho_{di} = \frac{M}{(1+w)V} \quad (2)$$

and:

$$n = 1 - \frac{\rho_{di}}{G_s \rho_w} \quad (3)$$

where:

G_s = the specific gravity of solids, that shall either be measured according to Test Method **D854** or estimated.

NOTE 3—Accurate measurement of the specific gravity of solids of many materials is difficult. The specific gravity of solids shall be determined with an estimated accuracy of ± 0.05 . For many materials, it is possible to estimate G_s within this accuracy.

7.5 Calculate the volume of the pores in the test specimen (V_p) as follows:

$$V_p = nV \quad (4)$$