



Designation: **F2661–07 F2661 – 07 (Reapproved 2015)**

Standard Test Method for Determining the Tribological Behavior and the Relative Lifetime of a Fluid Lubricant using the Spiral Orbit Tribometer¹

This standard is issued under the fixed designation F2661; the number immediately following the designation indicates the year of original adoption or, in the case of revision, the year of last revision. A number in parentheses indicates the year of last reapproval. A superscript epsilon (ϵ) indicates an editorial change since the last revision or reapproval.

1. Scope

1.1 This test method covers the quantitative determination of the friction coefficient and the lifetime of oils and greases, when tested on a standard specimen under specified conditions of preparation, speed, Hertzian stress, materials, temperature, and atmosphere, by means of the Spiral Orbit Tribometer (SOT). This test method is intended primarily as an evaluation of the lifetimes of fluid lubricants under vacuum and ambient conditions.

1.2 This standard may involve hazardous materials, operations, and equipment. *This standard does not purport to address all of the safety concerns, if any, associated with its use. It is the responsibility of the user of this standard to establish appropriate safety and health practices and to determine the applicability of regulatory limitations prior to use.*

2. Referenced Documents

2.1 *ASTM Standards:*²

[D1193 Specification for Reagent Water](#)

[F22 Test Method for Hydrophobic Surface Films by the Water-Break Test](#)

[F2215 Specification for Balls, Bearings, Ferrous and Nonferrous for Use in Bearings, Valves, and Bearing Applications](#)

[G115 Guide for Measuring and Reporting Friction Coefficients](#)

2.2 *Anti Friction Bearing Manufacturers Association Standards*³

[ANSI ABMA ISO 3290 \(AFBMA Standard 10 Balls\)](#)

3. Terminology

3.1 *Definitions:*

3.1.1 *coefficient of friction*—the dimensionless ratio of the friction force between two bodies to the normal force pressing these bodies together.

3.1.2 *fixed plate*—stationary, horizontal flat plate, typically through which a force (the “load”) is applied to the ball.

3.1.3 *friction coefficient limit*—maximum value that the friction coefficient is permitted to attain.

3.1.4 *guide plate*—physical element that deflects the ball to its original orbit radius.

3.1.5 *lubricant total amount*— mass of lubricant deposited on the entire ball surface at the beginning of the test.

3.1.6 *normalized lifetime*—number of ball orbits performed until the friction coefficient limit is reached divided by the lubricant total amount initially deposited on the ball.

3.1.7 *rotary plate*—flat plate rotating at a constant rate selected for the test.

3.1.8 *scrub zone*—Region of the ball’s orbit in which the ball is in contact with the guide plate.

3.1.9 *spiral orbit*—track traced by the ball on the fixed and rotating plates of the Spiral Orbit Tribometer. The track has a spiral shape.

¹ This test method is under the jurisdiction of ASTM Committee F34 on Rolling Element Bearings and is the direct responsibility of Subcommittee F34.02 on Tribology. Current edition approved June 1, 2007 April 1, 2015. Published July 2007 July 2015. Originally approved in 2007. Last previous edition approved in 2007 as F2661–07. DOI: 10.1520/F2661-07.10.1520/F2661-07R15.

² For referenced ASTM standards, visit the ASTM website, www.astm.org, or contact ASTM Customer Service at service@astm.org. For *Annual Book of ASTM Standards* volume information, refer to the standard’s Document Summary page on the ASTM website.

³ Available from American Bearing Manufacturers Association (ABMA), 8221 Old Courthouse Road, Suite 207 Vienna, Virginia 22182.

4. Summary of Test Method

4.1 A lubricated ball is clamped between two parallel plates. One of the plates rotates up to 210 rpm, causing the ball to roll in a near-circular orbit, but is actually an opening spiral. A clamping force, the “load”, provides a chosen mean Hertz stress (typically 1.5 GPa). The system is targeted to operate in the boundary lubrication regime due to the combination of the high load, the moderate speed, and the small amount of lubricant (approximately 50 µg). The ball rolls and pivots in a spiral orbit and is maintained in the orbit by the guide plate. The ball slides on the rotating plate when it contacts the guide plate. The measured force exerted by the ball on the guide plate is used to determine the friction coefficient. The tribometer runs until the coefficient of friction rises to values much larger than the initial, steady value. At this point the initial charge of lubricant has been depleted by tribo-degradation and the system is running virtually unlubricated. The normalized lifetime is obtained from the number of spiral orbits completed before reaching the chosen friction coefficient limit divided by the total lubricant mass on the ball at the beginning of the test. A minimum of four tests per lubricant and test condition shall be performed. Lubricants can be compared by calculating their average normalized lifetimes for a given set of test conditions.

5. Significance and Use

5.1 *Relevance of the Spiral Orbit Tribometer (SOT)*—The SOT was designed to evaluate the relative degradation rates of liquid lubricants in a contact environment similar to that in an angular contact bearing operating in the boundary lubrication regime. It functions as a screening device to quickly select the lubricants, evaluate the ability of various components of a lubricant (base oil, thickener, or additive) to lubricate a contact in rolling, pivoting, and sliding conditions simultaneously, and study their chemical decomposition if necessary. The SOT provides a means to study the tribological behavior of oils and greases during operation, while they undergo changes as a function of typical parameters encountered in the lubrication field (temperature, environment, materials used, load applied, and speed). Test conclusion is defined to be when a friction coefficient limit (typically an increase of 0.1 above the steady state value) is surpassed. Normalized lubricant lifetime is then defined as the number of orbits completed divided by the initial amount of lubricant used (in µg). The SOT was initially developed to evaluate lubricants for space applications, but is also relevant for conventional environments. Some results in vacuum are presented (Fig. 1). At this time, no data for tests in ambient conditions have been published (see Fig. 2). The user of this test method should determine to their own satisfaction whether results of this test procedure correlate with field performance or other bench test procedures.

6. Apparatus

6.1 *The Spiral Orbit Tribometer (SOT)*—See Fig. 3.

6.1.1 *General description*—Fig. 3 shows a schematic drawing of a typical SOT. The system consists of a lubricated ball rolling and pivoting between a fixed plate and a rotary plate. The load is applied through the fixed plate. The track is a spiral and the ball is returned to its original orbit radius by contacting the guide plate, which forces the ball to return to its original radius each orbit. The friction coefficient is determined by the measuring the force on the guide plate when the ball contacts the guide plate. A piezoelectric force transducer is attached to the guide plate. This force, divided by twice the normal load, is the friction coefficient.

6.1.2 *Motor drive*—A variable speed motor, capable of constant speed, is required. Rotating plate speeds are typically in the range 1 to 210 rpm (0.10 to 22 rad.s⁻¹). The effective stiffness of the axis shall be at least 1.8 E +05 Newton/meter axial in the load direction, 3.6 E +08 Newton/meter radial and 1.13 E +05 Newton-meter/Radian moment. The TIR of the motor shaft shall be 0.0254 millimeters maximum.

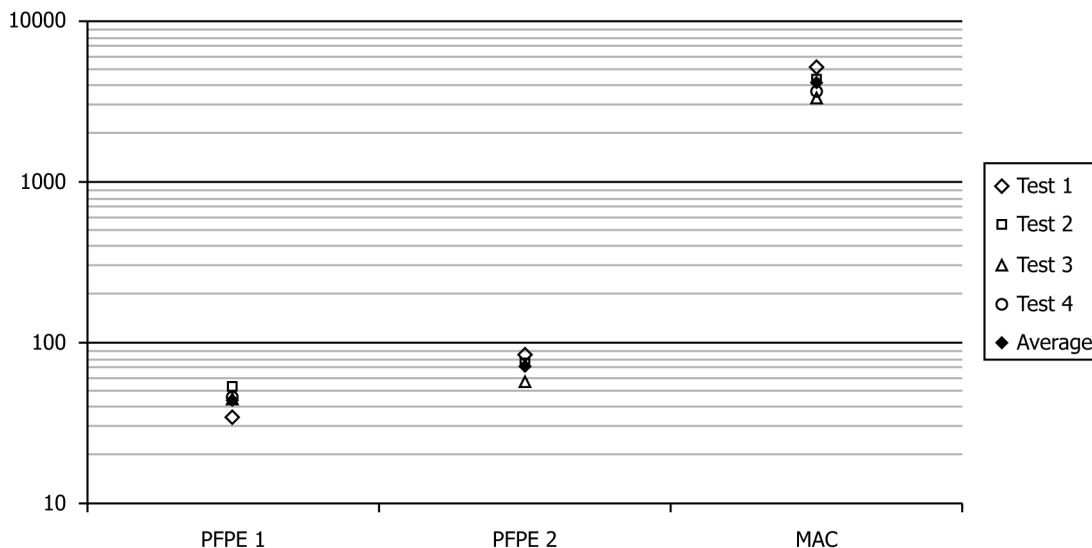

Pepper, S.V., Kingsbury, E.P., “Spiral Orbit Tribometry – Part II: Evaluation of Three Liquid Lubricants in Vacuum”, *Tribol. Trans.*, V 46, 1, pp 65-69, 2003

FIG. 1 Relative lifetimes of three typical space lubricants at 23°C in vacuum on 52100 steel

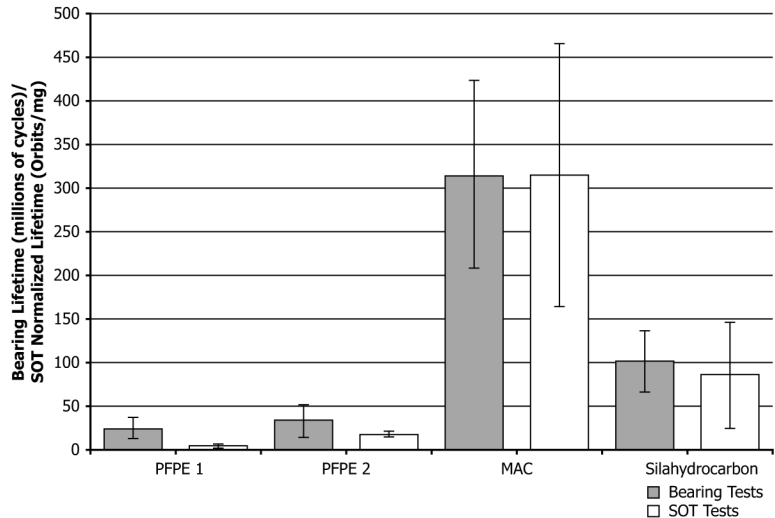

Bazinet, D.G., Espinosa, M.A., Loewenthal, S.H., Gschwender, L., Jones, W.R., Jr., Predmore, R.E., "Life of Scanner Bearings with Four Space Liquid Lubricants", *Proc. 37th Aerospace Mech. Symp.*, Johnson Space Center, May 19-21, 2004

FIG. 2 Comparison between full scale bearing tests** and SOT data at 23°C on 440C steel.

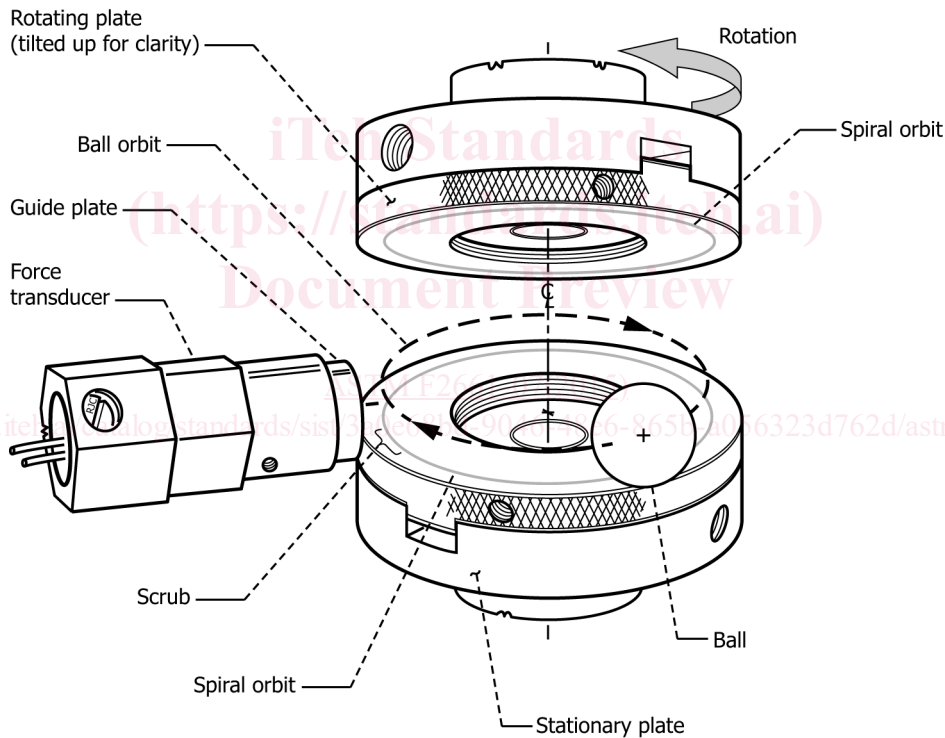

FIG. 3 Detail of the Spiral Orbit Tribometer

6.1.3 *Fixed load plate*— The load plate shall have an axial stiffness of at least 1.8 E +08 Newton/meter in the load direction. The effective radial stiffness of the plate axis shall be at least 1.8 E+08 Newton/meter and the moment stiffness shall be at least 1.13 E +05 Newton-meter/Radian.

6.1.4 *Orbit counter*— The SOT shall be equipped with a revolution counter or its equivalent that will record the number of ball orbits. The tribometer would preferably have the ability to shut off after a pre-selected number of orbits or friction coefficient has been reached.

6.1.5 *Applied load*— The fixed plate is attached to a system to apply the load, up to 222.5 N (50 lb.), providing the desired Hertzian stress, typically 1.5 GPa.

6.1.6 *The instruments and gauges*—



6.1.6.1 *Friction force*— The friction coefficient is determined by measuring the force on the guide plate while the ball contacts the guide plate. This force is measured using a piezoelectric force transducer and a charge amplifier. The friction force and the coefficient of friction can then be obtained as explained in Section 11. The load cell shall be linear to within 2 % across the entire temperature range of the test.

6.1.6.2 *Environment*— The SOT operates in either one atmosphere air, under a cover gas, or vacuum. When operating under vacuum or ultrahigh vacuum, a cold cathode pressure gauge attached to the chamber monitors the pressure. A hot cathode gauge should be avoided since electrons from the filament could alter lubricant chemistry. It is the responsibility of the user to determine the chemical purity of the environment and gas to establish the contribution to tribochemistry.

6.1.6.3 *Measurement of the temperature* —When a controlled temperature is required, the temperature is monitored using a thermocouple (for example, K-type) attached to the stationary disk during the test.

7. Reagents and Materials

7.1 Balls, plates, guide plates. Typical instrument bearing materials may be of 440C material, but other materials may be used to simulate the bearing application.

7.1.1 *Test balls*—Test balls shall be 12.7 mm (0.5 inch) diameter, grade 25 or better, made with 440C stainless steel. Their recommended Rockwell hardness shall be 58 to 62. See Specification F2215 or ANSI ABMA ISO 3290 (AFBMA Standard 10) for ball specification reference. Other materials may be used to simulate specific application chemistry.

7.1.2 *Plates, Guide plates*—The fixed plate and the rotary plate are disks of 50.8 mm (2 inch) in diameter, may be made with 440C stainless steel, or any desired material. Surface roughness of 0.05 mm average roughness or less is recommended. The guide plates are small cylinders 12.7 mm (0.5 inch in diameter), with a polished surface of 0.05 mm average roughness or less (recommended). The recommended Rockwell hardness for 440C shall be 58 to 62. Stationary and rotary plates should be made with the same material. Any bearing material can be used, depending on the application being simulated. The recommended values should be used unless differences are required to simulate a specific application.

7.1.3 Care must be taken in surface preparation and handling to avoid surface damage or contamination after cleaning that alters the material. Typical cleaning methods may be used when the results will pass an Test Method F22 standard test for wettability and do not damage the materials or adversely alter the sample surfaces. A wettability test using the intended lubricant to evaluate the ball and plate cleaning method is recommended.

7.1.4 Reagent grade chemicals shall be used per Test Method F22 section 8.1. It is the user's responsibility to prevent contamination or adulteration of the lubricant samples, and prevent materials used to clean or lubricate from harming the samples.

8. Hazards

8.1 *Use of solvents*— Operator will refer to the safety data sheet of all the solvents used and will take appropriate precautions.

8.2 *Use of ultrasonic cleaning systems (if applicable)*—Operator will refer to the instruction manual of the ultrasonic bath before use.

8.3 *Use of ultra violet (U.V.)/ozone cleaning system (if applicable)*—Operator will refer to the instruction manual of the U.V./ozone cleaning system before use. Special care will be taken to check the compatibility of the materials used to a U.V. and ozone exposure.

8.4 *Ultrahigh vacuum chamber (if applicable)*—The vacuum chamber will be operated with appropriate copper or elastomer seals to reach ultrahigh vacuum, and will not be opened until the inside of the chamber has reached atmospheric pressure.

9. Sampling, Test Specimens, and Test Units

9.1 *Test specimens*— Specimens (plates, balls, guide plates) will be kept for further analysis, if required.

9.2 *Test units*—Only SI units will be used.

10. Procedure

10.1 Cleaning of the parts and tools may be any method that simulates the application. It is recommended that the results of cleaning procedures are tested using a water break free test such as Test Method F22 using reagent grade water per Specification D1193, or a wettability test using the intended oil. Since many variations of cleaning methods exist and their results may have a strong effect on the results, it is the user's responsibility to determine the effectiveness and safety of the cleaning methods. The details of the cleaning methods shall described in the test report.

10.2 *Lubrication of the balls—balls*—Lubrication of the test system is to the ball only. The objective is to lubricate the balls with a small and controlled amount of lubricant. The target amount is as close as possible to 50 +/- 2 µg for a 12.7 mm diameter ball.

10.2.1 *Lubrication of the balls with oil—oil:*

10.2.1.1 Preparation of a dilute solution of oil:

(1) Choose a solvent suitable for the oil to be tested. The user must determine that the solvent does not harm the sample surface or alter the lubricant.