



Designation: ~~D6496 – 04a~~ (Reapproved 2009) D6496/D6496M – 04a (Reapproved 2015)^{ε1}

Standard Test Method for Determining Average Bonding Peel Strength Between Top and Bottom Layers of Needle-Punched Geosynthetic Clay Liners¹

This standard is issued under the fixed designation ~~D6496~~; D6496/D6496M; the number immediately following the designation indicates the year of original adoption or, in the case of revision, the year of last revision. A number in parentheses indicates the year of last reapproval. A superscript epsilon (ϵ) indicates an editorial change since the last revision or reapproval.

^{ε1} NOTE—Units information and designation were corrected editorially in July 2015.

1. Scope

1.1 This test method covers the laboratory determination of the average bonding strength between the top and bottom layers of a sample of a geosynthetic clay liner (GCL).

1.2 The values stated in either SI units or inch-pound units are to be regarded separately as the standard. The values in inch-pound units are in parentheses for information; stated in each system may not be exact equivalents; therefore, each system shall be used independently of the other. Combining values from the two systems may result in non-conformance with the standard.

1.3 *This standard does not purport to address all of the safety concerns, if any, associated with its use. It is the responsibility of the user of this standard to establish appropriate safety and health practices and determine the applicability of regulatory limitations prior to use.*

2. Referenced Documents

2.1 *ASTM Standards:*²

~~D76~~D76/D76M Specification for Tensile Testing Machines for Textiles

~~D4439~~ Terminology for Geosynthetics

3. Terminology

3.1 *Definitions:*

3.1.1 *geosynthetic, n*—a product manufactured wholly or in part from polymeric material used with soil, rock, earth, or other geotechnical engineering related material as an integral part of a project, structure, or system. D4439

3.1.2 *geosynthetic clay liner, n*—a manufactured hydraulic barrier consisting of clay bonded to a layer or layers of geosynthetic material(s). (Currently being balloted under D35 Committee on Terminology) Terminology.)

4. Summary of Test Method

4.1 The top and bottom layers of a geosynthetic clay liner are gripped individually in tensile grips and pulled at a constant rate of extension by a tensile testing machine until the top and bottom layers of the specimen separate. The average bonding peel strength of the test specimen can be calculated from machine scales, dials, recording charts, or an interface computer.

5. Significance and Use

5.1 The bonding strength test for the top and bottom layers of the geosynthetic clay liner is intended to be an index test. It is anticipated that the results of the test will be used to evaluate the quality of the bonding process.

6. Apparatus

6.1 *Tensile Testing Machine*—A constant rate of extension (CRE) type of testing machine described in Specification ~~D76~~D76/D76M shall be used with a minimum precision measuring capability of 0.1 N/m (~~5.71~~5.71 × 10⁻⁴ ~~lbf/in.~~ lbf/in.).

¹ This test method is under the jurisdiction of ASTM Committee D35 on Geosynthetics and is the direct responsibility of Subcommittee D35.04 on Geosynthetic Clay Liners.

Current edition approved Nov. 1, 2009/July 1, 2015. Published January 2010/July 2015. Originally approved in 1999. Last previous edition approved in 2004/2009 as ~~D6496 – 04a~~ D6496 – 04a(2009). DOI: ~~10.1520/D6496-04AR09~~ 10.1520/D6496_D6496M-04AR15E01.

² For referenced ASTM standards, visit the ASTM website, www.astm.org, or contact ASTM Customer Service at service@astm.org. For *Annual Book of ASTM Standards* volume information, refer to the standard's Document Summary page on the ASTM website.

6.2 *Clamps*—The clamps shall be a minimum 25 by 100 mm (±1 by 4 in.) and with appropriate clamping power to prevent slipping or crushing (damage).

6.3 *Die or Template*, 100 by 200 mm (±1 mm) (4 by 8 in.).

6.4 *Miscellaneous*, knives, razor, and the like, as required.

7. Test Specimen

7.1 The sample received at the testing laboratory should be in satisfactory condition and representative of the product manufactured or delivered to a site, or both.

7.2 The size of the die or template for cutting specimens is 100 by 200 mm (4 by 8 in.).

7.3 The loss of clay during the specimen cutting process should have no bearing on the results of the test.

7.4 A minimum of five test specimens should be cut from the laboratory sample such that they are representative of the entire roll width. All specimens should be parallel to the machine direction.

8. Conditioning

8.1 The test specimen shall be tested as received.

9. Procedure

9.1 *Obtain Specimens*—Using the die, or template and razor, and other necessary apparatus, carefully cut from the laboratory sample five test specimens. The five specimens should be randomly selected from locations on the sample, but should be distributed across the sample. All specimens should be cut parallel to the machine direction. Using a knife or razor, separate the top and bottom layer of the GCL for the first 50 ± 3 mm (2 ± 0.1 in.); 50 ± 3 mm [2 ± 0.1 in.].

9.2 *Machine Set-Up Conditions*—Adjust the distance between the clamps at the start of the test to 50 ± 3 mm (2 ± 0.1 in.); [2 ± 0.1 in.]. Set the CRE at 300 mm/min. (12 in./min.); [12 in./min.].

9.3 *Insertion of Specimen in Clamps*—Mount the specimen centrally in the clamps. The specimen must be visually observed above the clamp. The specimen length in the machine direction must be parallel to the direction of application of force.

9.4 *Measurement of Bonding Peel Strength*—Start the tensile testing machine. This is considered the start of the peel test and represents zero grip separation. Take readings of force and time starting from 50 mm (2 in.) [2 in.] of grip separation until 250 mm (10 in.) [10 in.] of grip separation. The average recorded peeling force of the GCL over 200 mm (8 in.) [8 in.] of grip separation is required and will signify a complete test of the specimen. (See Fig. 1).

NOTE 1—If significant elongation of the geotextile continues after 50 mm (2 in.) [2 in.] additional grip peeling of the GCL, the recording interval should be adjusted. The recording interval should correspond to 200 mm (8 in.) [8 in.] of grip separation during the peeling of the GCL.

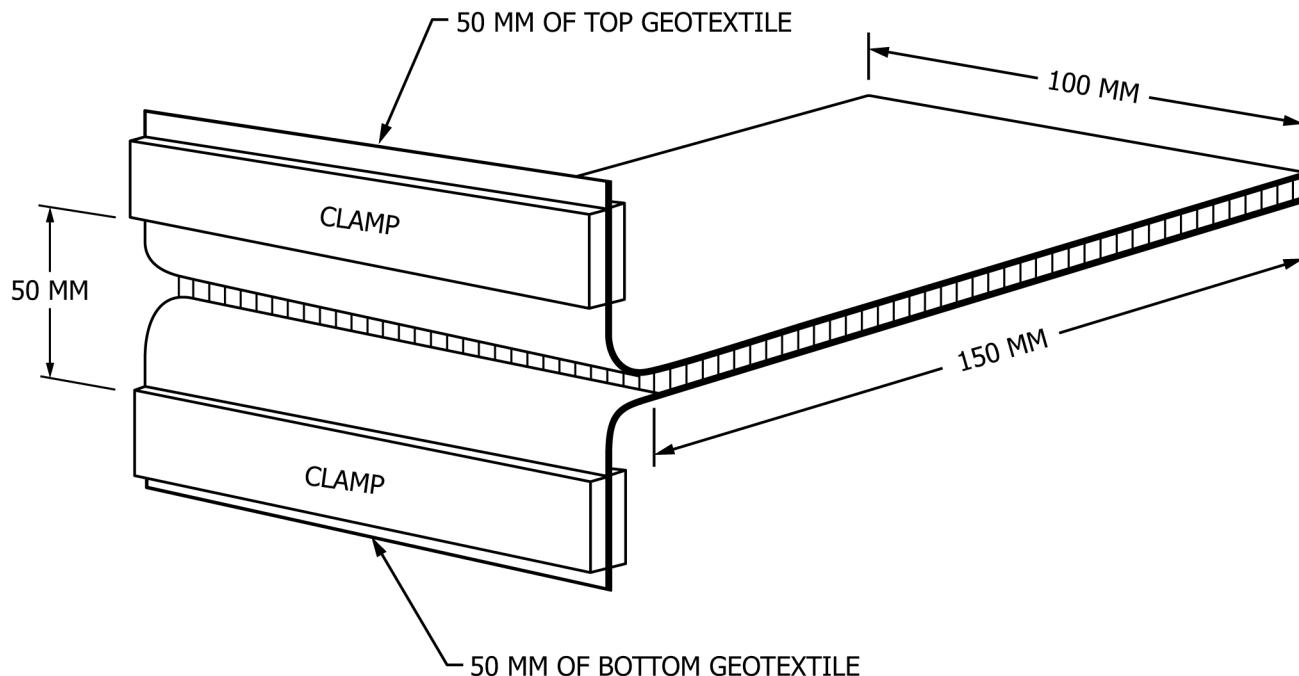

FIG. 1 Measurement of Bonding Peel Strength

9.4.1 Readings of force and time shall be taken at a minimum rate of 20 readings per second.

9.4.2 If a specimen slips in the jaws, or if for any reason attributable to faulty operation the results fall significantly below the average for the set of specimens, discard the results and test another specimen. Continue until the required number of readings have been taken.

10. Calculation

10.1 *Bonding Peel Strength*—Calculate the bond strength of individual specimens, that is, the average force to cause a specimen to separate expressed in N (lbf) [lbf] of width, using the following equation:

$$\alpha_f = F_{avg} / W_S \tag{1}$$

where:

- α_f = bonding peel strength, N/m (lbf/in.) of width,
- F_{avg} = observed average force over a grip separation of 50 mm (2 in.) to 250 mm (10 in.), N (lbf), and
- W_S = specified specimen width, m (in.).

- α_f ≡ bonding peel strength, N/m [lbf/in.] of width,
- F_{avg} ≡ observed average force over a grip separation of 50 mm [2 in.] to 250 mm [10 in.], N [lbf], and
- W_S ≡ specified specimen width, m [in.].

iTeh Standards
(<https://standards.itih.ai>)
Document Preview

[ASTM D6496/D6496M-04A\(2015\)e1](https://standards.itih.ai/catalog/standards/sist/af510b61-baee-4138-a54b-ba64aa075328/astm-d6496-d6496m-04a2015e1)

<https://standards.itih.ai/catalog/standards/sist/af510b61-baee-4138-a54b-ba64aa075328/astm-d6496-d6496m-04a2015e1>