



Designation: C1629/C1629M – 15

Standard Classification for Abuse-Resistant Nondecorated Interior Gypsum Panel Products and Fiber-Reinforced Cement Panels¹

This standard is issued under the fixed designation C1629/C1629M; the number immediately following the designation indicates the year of original adoption or, in the case of revision, the year of last revision. A number in parentheses indicates the year of last reapproval. A superscript epsilon (ϵ) indicates an editorial change since the last revision or reapproval.

1. Scope*

1.1 This standard establishes classifications of abuse resistance based on the abrasion resistance and impact resistance performance of nondecorated interior gypsum panel products and fiber-reinforced cement panels (abuse resistant wall panels).

1.1.1 This standard is a method of classifying gypsum panel product performance and is not intended to classify systems for abuse resistance.

1.2 The values stated in inch-pound and SI (metric) units are to be regarded separately as standard. Within the text, the SI units are shown in brackets. The values stated in each system shall be used independent of the other. Values from the two systems shall not be combined.

1.3 *This standard does not purport to address all of the safety concerns, if any, associated with its use. It is the responsibility of the user of this standard to establish appropriate safety and health practices and determine the applicability of regulatory limitations prior to use.*

2. Referenced Documents

2.1 ASTM Standards:²

- C11 Terminology Relating to Gypsum and Related Building Materials and Systems
- C473 Test Methods for Physical Testing of Gypsum Panel Products
- C840 Specification for Application and Finishing of Gypsum Board
- C1154 Terminology for Non-Asbestos Fiber-Reinforced Cement Products
- D4977 Test Method for Granule Adhesion to Mineral Surfaced Roofing by Abrasion

¹ This classification is under the jurisdiction of ASTM Committee C11 on Gypsum and Related Building Materials and Systems and is the direct responsibility of Subcommittee C11.01 on Specifications and Test Methods for Gypsum Products.

Current edition approved June 1, 2015. Published July 2015. Originally approved in 2005. Last previous edition approved in 2014 as C1629/C1629M – 14a. DOI: 10.1520/C1629_C1629M-15.

² For referenced ASTM standards, visit the ASTM website, www.astm.org, or contact ASTM Customer Service at service@astm.org. For *Annual Book of ASTM Standards* volume information, refer to the standard's Document Summary page on the ASTM website.

D5420 Test Method for Impact Resistance of Flat, Rigid Plastic Specimen by Means of a Striker Impacted by a Falling Weight (Gardner Impact)

E695 Test Method of Measuring Relative Resistance of Wall, Floor, and Roof Construction to Impact Loading

2.2 ISO Documents:

ISO 6707-1 Building and Civil Engineering—Vocabulary—Part 1: General Terms

3. Terminology

3.1 Definitions of terms shall be in accordance with Terminologies C11 and C1154.

3.2 Definitions of Terms Specific to This Standard:

3.2.1 *failure (hard body impact)*, *n*—test result constituted by the penetration or deformation of the wall cavity by the impact head establishing a residual deflection of the panel exceeding the nominal thickness of the test panel.

3.2.2 *structural failure (soft body impact)*, *n*—a test result constituted by the penetration or deformation of the wall cavity by the soft body impact bag establishing a residual deflection of any area on the test panel that exceeds the nominal thickness of the test panel.

3.2.2.1 *deformation*, *n*—change of shape or dimension or both.

ISO 6707-1

3.2.2.2 *surface damage*, *n*—pulverization of the core of the test panel at the point of impact, which is evidenced by cracking, creasing, or other visible damage short of failure as defined in 3.2.2.

3.2.3 *residual deflection*, *n*—permanent deformation of a building element, component, or structure after removal of applied force.

3.2.3.1 *Discussion*—Also called permanent set or residual deformation.

4. Significance and Use

4.1 Each abuse/impact property of abuse resistant wall panels is divided into three classification levels. The three levels of classification are: Level I, Level II, and Level III, with Level I representing the lowest rating for any given property. The test methods specified are utilized to establish the abuse-resistance classification of an abuse resistant wall panel. Each

*A Summary of Changes section appears at the end of this standard

classification level requires a minimum overall specified performance. Any classified abuse resistant wall panel can be used at a classification level which is rated lower than the highest level qualified.

5. Basis of Classification

5.1 Abuse resistant wall panels are classified into one of three levels of abuse resistance based on minimum performance when tested in accordance with test methods that evaluate surface abrasion, indentation, soft body impact, and hard body impact as specified in 6.1 – 6.4.

5.2 Minimum requirements for each level are as shown in Tables 1-4.

6. Test Methods

6.1 *Surface Abrasion Test*—This test is conducted in accordance with Test Method D4977 using a total load of 25.0 lb [11.3 kg]. The specimen is conditioned to constant weight at 70°F [21°C] and 50 % relative humidity and subjected to 50 abrasion cycles. The abrasive motion on the specimen creates measurable surface wear or indentation which is measured to determine the level of surface abrasion resistance.

NOTE 1—It is especially important to prepare the apparatus and condition the brush as specified in Test Method D4977.

6.2 *Indentation Test*—This test, conducted in accordance with Test Method D5420 (Gardner Impact), utilizes procedure GC, with a 5/8-in. [15.9 mm] hemispherical head and a 72 in.-lb [12.6 J] impact energy. The depth of the indentation is measured to determine the level of indentation resistance.

6.3 *Soft Body Impact Test*—This test, conducted in accordance with Method E695, is performed with the use of the standard leather bag filled with steel pellets to a weight of 60.0 lb [27.2 kg] and dropped through an angular distance until the specimen is impacted. The point of impact shall be midway between studs at the mid-height of the test panel.

6.3.1 Apparatus:

6.3.1.1 *Wall Assembly*—A single 4 by 8 ft [1200 by 2400 mm] panel is mounted on a wood stud wall constructed of nominal 2 by 4 in. [38 by 89 mm] studs. The studs shall be spaced 16 in. [400 mm] on center, and the wall shall be constructed with the abuse resistant wall panel attached parallel to the framing members following methods outlined in Test Method C840 sections on “Application of Gypsum Board” and “System I: Application of Single-Ply Gypsum Board to Wood Framing Members.”

6.3.1.2 *Measurement Tools*—A vernier or digital caliper style depth gauge capable of measuring not less than 2 in. [50 mm] at 0.0005 inch [0.01 mm] resolution shall be used to measure the depth of residual deflection. The depth gauge shall

**TABLE 1 Performance Requirements
Surface Abrasion Resistance**

Classification Level	Abraded Depth Maximum in. [mm]
1	0.126 [3.2]
2	0.059 [1.5]
3	0.010 [0.3]

**TABLE 2 Performance Requirements
Indentation Resistance**

Classification Level	Indentation Maximum in. [mm]
1	0.150 [3.8]
2	0.100 [2.5]
3	0.050 [1.3]

**TABLE 3 Performance Requirements
Soft Body Impact Test**

Classification Level	Soft Body Minimum ft-lbf [J]
1	90 [122]
2	195 [265]
3	300 [408]

**TABLE 4 Performance Requirements
Hard Body Impact**

Classification Level	Hard Body Minimum ft-lbf [J]
1	50 [68]
2	100 [136]
3	150 [204]

be attached to a base of sufficient width to span the 16 in. [400 mm] between the studs of the wall assembly. The base shall be sufficiently stiff to resist bending. A micrometer capable of measuring 1 in. [25 mm] at 0.001 [0.01 mm] resolution shall be used to measure the average thickness of the panel as specified in Test Method C473.

6.3.2 A single specimen is repeatedly impacted at a single point of impact in one cavity with the drop height being increased by 6 in. [150 mm] (30 lbf [133 N]) with each successive drop until structural failure as defined in 3.2.2 is achieved.

6.3.2.1 The level of energy, surface damage, deformation, and residual deflection at the point of impact are recorded following each impact. The residual deflection shall be measured from the face side of the panel.

(1) Residual deflection shall be visually evaluated to determine where the deepest deflection occurs. Three measures shall be made in this area to the nearest 0.001 in. [0.01 mm] and then averaged. This measurement shall be used to determine the depth of the residual deflection.

NOTE 2—Surface damage and deformation, which do not constitute structural failure, may compound the results.

6.3.3 Following structural failure in the initial cavity, the procedure described in 6.3.2 is repeated on the next cavity, beginning with a drop height of 6 in. [150 mm] higher than the drop height causing structural failure in 6.3.2.

6.3.3.1 If structural failure in the second cavity occurs with the first drop, the test is terminated and the level of energy required to cause the failure is calculated to determine the soft body impact resistance.

6.3.3.2 If structural failure in the second cavity occurs on the second or subsequent drop, repeat the procedure described

in 6.3.3 in the next cavity, beginning with a drop height 6 in. [150 mm] higher than the drop height causing structural failure in the second cavity.

6.3.4 Repeat the procedures in 6.3.2 – 6.3.3.2 until structural failure occurs on a single drop in a fresh cavity, at which time the test is terminated and the level of energy required to cause the failure is calculated to determine the soft body impact resistance.

6.4 *Hard Body Impact Test*—This test is conducted in accordance with the method described in Annex A1 or with another apparatus equipped with an equivalent impact head that is capable of delivering equivalent impact loads.

ANNEX

(Mandatory Information)

A1. HARD BODY IMPACT TEST

A1.1 Scope

A1.1.1 The hard body impact test measures resistance to penetration of a wall panel when impacted by a rigid body. Failure in the hard body impact test is achieved when the impacting head completely penetrates through the test panel, or the depth of the indentation exceeds the thickness of the product being tested when measured from the face side following impact, or both.

A1.2 Summary of Test Method

A1.2.1 A nominal 2 by 2 ft [610 by 610 mm] specimen is mounted to the apparatus frame. A ramming arm impactor strikes the wall specimen while swinging in an arc. The impactor is dropped from a fixed height to impart specific design energy to the wall specimen. Weights are progressively added to the impactor to increase the design impact energy until specimen failure occurs. For each impact, a new test specimen is used.

A1.3 Significance and Use

A1.3.1 The test method measures relative performance of interior wall panel materials. Although the test panel is mounted on framing and tested vertically as a wall assembly, the impact damage is normally limited to a small area.

A1.4 Apparatus

A1.4.1 The apparatus consists of a rigid frame with a ramming arm pinned to swing in an arc. See Figs. A1.1 and A1.2. The frame is constructed of 14 ga, 1 5/8 by 1 5/8 in. [41 by 41 mm] B-Line B24 Regular Framing Channels.

A1.4.1.1 The dimensions and details of the ramming arm impactor are shown in Fig. A1.3. The ramming arm impactor consists of a cylindrical steel impact head (made by milling a round steel bar), a structural steel tubing with square cross-section, two square steel plates (front and rear end plates of the structural steel tubing), a steel plate pivot arm, a round steel bar (to add weights), and a rectangular steel plate attached to the bottom of the structural steel tubing. The total weight of the components of the ramming arm impactor is 20.0 lb [9.07 kg] ± 0.5 %, as shown in Table A1.1. The center of mass of the ramming arm impactor coincides with the location of the steel round bar (that is, the weight bar). Additional weights are attached to the weight bar to increase the impacting energy.

A1.4.1.2 The ramming arm impactor shall have a suitable mechanism to secure it at the top of the swing. An example of such a mechanism is a small eyebolt attached to the back of the impactor. When released from the top of the swing, the drop height of the center of mass of the ramming arm impactor shall be 12.0 in. [305 mm].

A1.4.1.3 The ramming arm is located such that the face of the impactor head, when hanging free at the bottom of the arc, is in the same plane as the surface of the test specimen so that, when dropped, the impactor head strikes the surface of the specimen at the bottom of the arc.

A1.5 Test Specimen

A1.5.1 The test wall assembly shall be constructed by attaching a 2 by 2 ft [610 by 610 mm] specimen of the interior wall panel material to a frame of 3 5/8 in. [92 mm] deep 20 ga steel studs with Type S-12 bugle head screws spaced 8 in. [200 mm] o.c. as shown in Fig. A1.4. The length of the screws shall be 1 1/4 in. [32 mm] for panels up to 5/8 in. [15.9 mm] in thickness. For panels with thickness greater than 5/8 in. [15.9 mm], the length of the screws shall be at least 5/8 in. [16 mm] longer than the panel thickness.

TABLE A1.1 Weight (Mass) Schedule for the Components of the Ramming Arm Impactor

Component	Weight lb, ± 0.5 %	Mass kg, ± 0.5 %
Structural Steel Tubing (square cross-section)	8.10	3.67
Steel Plate Pivot Arm	1.10	0.50
Front Square Steel Plate (end plate attached to the front of the structural steel tubing)	0.90	0.41
Rear Square Steel Plate (end plate attached to the back of the structural steel tubing)	0.90	0.41
Cylindrical Steel Impact Head	1.90	0.86
Steel Round Bar (Weight Bar)	2.60	1.18
Bottom Rectangular Steel Plate (attached to the bottom of the structural steel tubing)	4.50	2.04

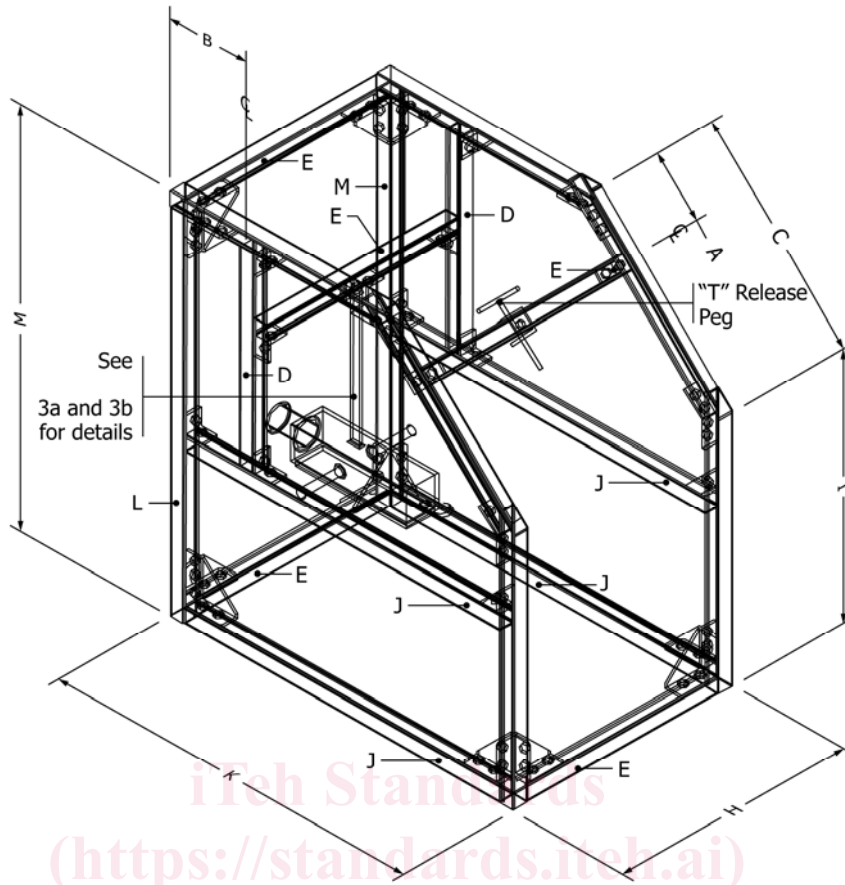

	in.	mm		in.	mm
A	6 1/16	154.0	I	26 5/16	668.3
B	8 9/16	211.1	J	34 1/4	870.0
C	20 5/16	515.9	K	37 1/2	952.5
D	20 9/16	522.3	L	39 1/16	992.2
E	20 3/4	527.1	M	40 11/16	1033.5
H	24	609.6			

NOTE 1—All framing members shall be B-Line B24 Regular Framing Channels cut to the specified dimensions in this sketch. These channels are 14 gauge and have an outside dimension of 1 5/8 by 1 5/8 in. [41 by 41 mm].

FIG. A1.1 Axonometric of Hard Body Apparatus Framing Members (not to scale)

A1.6 Preparation of Apparatus

A1.6.1 The apparatus shall be securely anchored to a level floor to prevent sliding or rocking of the apparatus during impact.

A1.7 Procedure

A1.7.1 The test wall assembly shall be securely clamped to the face of the apparatus so that the surface of the test specimen is in the same plane as the face of the impact head.

A1.7.1.1 A new test wall assembly shall be used for each impact.

A1.7.2 The ramming arm is raised to the top or the arc and secured with a pin.

A1.7.3 The pin is removed, allowing the arm to swing freely and strike the test specimen.

A1.7.4 A new test wall assembly is mounted to the apparatus and the weight on the impactor is increased by adding 2.50 lb [1.10 kg] to the weight bar and the test repeated.

A1.7.5 The test shall be performed by incrementally increasing the barbell free weights on the impactor until a failure impact energy is achieved.

A1.7.5.1 The failure impact energy is defined as the minimum energy required for the impactor to penetrate through the face of the panel into the stud cavity, or when the depth of the indentation exceeds the nominal thickness of the product being tested when measured from the face side.

A1.7.6 Testing shall continue until the failure impact energy is confirmed on three identical assemblies for each wall panel material being tested.

A1.7.7 Impact energy and damage at each test shall be recorded.

A1.8 Calculation of Energy Impact

A1.8.1 Impact energy in ft-lb units is calculated as the product of the weight of the impacting instrument and the drop height: