



Designation: F1661 – 09 (Reapproved 2015)

Standard Test Method for Determining the Contact Bounce Time of a Membrane Switch¹

This standard is issued under the fixed designation F1661; the number immediately following the designation indicates the year of original adoption or, in the case of revision, the year of last revision. A number in parentheses indicates the year of last reapproval. A superscript epsilon (ϵ) indicates an editorial change since the last revision or reapproval.

1. Scope

1.1 This test method covers the determination of the contact bounce time of a membrane switch.

1.2 The values stated in SI units are to be regarded as standard. No other units of measurement are included in this standard.

1.3 *This standard does not purport to address all of the safety concerns, if any, associated with its use. It is the responsibility of the user of this standard to establish appropriate safety and health practices and determine the applicability of regulatory limitations prior to use.*

2. Referenced Documents

2.1 *ASTM Standards:*²

D2240 Test Method for Rubber Property—Durometer Hardness

F2592 Test Method for Measuring the Force-Displacement of a Membrane Switch

F1680 Test Method for Determining Circuit Resistance of a Membrane Switch

3. Terminology

3.1 *Definitions:*

3.1.1 *contact bounce*—intermittent contact opening and contact closure that may occur after switch operation.

3.1.2 *contact bounce time (break)*, T_{CBB} —the time period measured from the first instant V_M is equal to the SUTV until it constantly remains below the SLTV after the last instant it rises above the SUTV. If V_M does not rise above SUTV during the time interval, $T_{CBB} = 0$, (see Fig. 1).

3.1.3 *contact bounce time (make)*, T_{CBM} —the time period measured from the first instant V_M is equal to the SLTV until

it constantly remains above the SUTV after the last instant it falls below the SLTV. If V_M does not fall below SLTV during the time interval, $T_{CBM} = 0$, (see Fig. 2).

3.1.4 *lower transition voltage, LTV*—the voltage at which the switched logic device transitions to an “off” state.

3.1.5 *membrane switch*—a momentary switching device in which at least one contact is on, or made of, a flexible substrate.

3.1.6 *resistor, load, R_L* —load resistance in series with switch under test.

3.1.7 *specified lower transition voltage, SLTV*—minimum allowable LTV.

3.1.8 *specified upper transition voltage, SUTV*—minimum allowable UTV.

3.1.9 *upper transition voltage, UTV*—the voltage at which the switched logic device transitions to an “on” state.

3.1.10 *voltage, measured, V_M* —voltage measured across load Resistor (R_L) by the oscilloscope and measured on it's screen or voltage measured across the switch under test when a contact bounce measuring device is used.

4. Significance and Use

4.1 Contact bounce time is essential to manufacturers and users when designing interface circuitry because it specifies the time delay necessary in the decoder circuitry to avoid any false signals caused by contact bounce. Allowing for time delay makes the switch operation considerably more reliable.

5. Interference

5.1 The following parameters may affect the results of this test:

5.1.1 Mechanical probe materials (hardness) and speed will affect results.

6. Apparatus

6.1 *Test Probe*, built to either of the configuration shown in Fig. 3 and Fig. 4 are acceptable but must be made of an inert elastomeric material with a hardness number equivalent to $A/45 \pm 5$ as measured in accordance with Test Method D2240. Test probes that do not meet the above criteria must be fully specified and recorded.

¹ This test method is under the jurisdiction of ASTM Committee F01 on Electronics and is the direct responsibility of Subcommittee F01.18 on Printed Electronics.

Current edition approved June 1, 2015. Published August 2015. Originally approved in 1995. Last previous edition approved in 2009 as F1661 – 09. DOI: 10.1520/F1661-09R15.

² For referenced ASTM standards, visit the ASTM website, www.astm.org, or contact ASTM Customer Service at service@astm.org. For *Annual Book of ASTM Standards* volume information, refer to the standard's Document Summary page on the ASTM website.

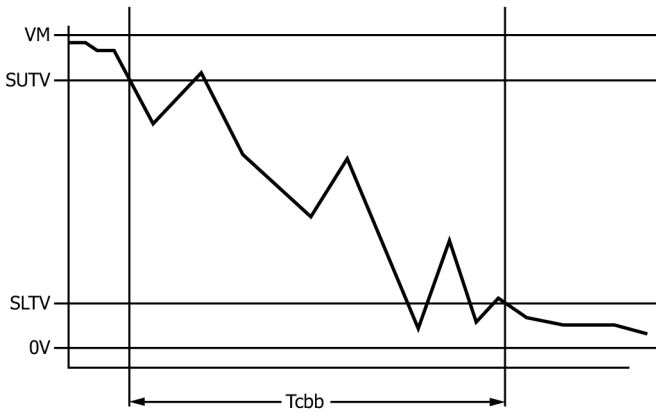

FIG. 1 Contact Bounce on Switch Break

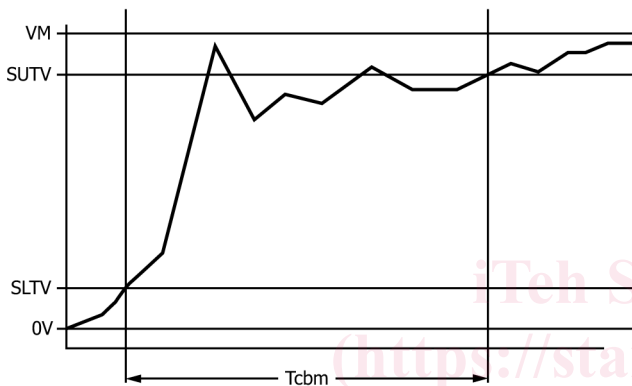

FIG. 2 Contact Bounce on Switch Make

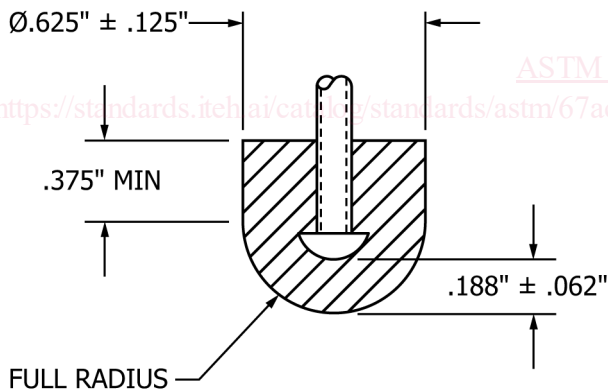

FIG. 3 Test Probe Option

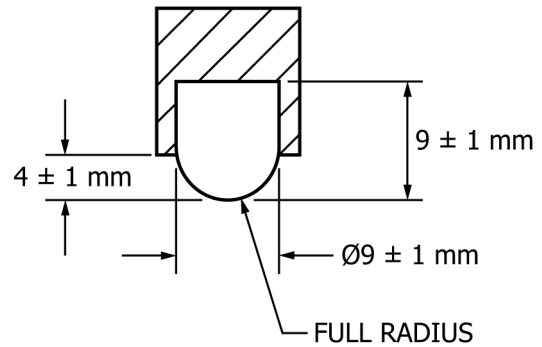

FIG. 4 Test Probe Option

7.1.1 Determine F_{max} or F_c (whichever is greater) per Test Method F2592.

7.1.2 Determine switch resistance (R_s) per Test Method F1680.

7.1.3 Secure switch on test surface.

7.1.4 Connect switch terminals as shown in Fig. 5 so that:

$$R_L = 10 \text{ to } 100 \text{ times } R_s$$

7.1.5 Adjust oscilloscope to initial settings as follows:

7.1.5.1 One half to 1.0 V/cm vertical, and

7.1.5.2 Two to 3 ms/cm horizontal.

7.1.5.3 Set SUTV per Fig. 6 if known. If not known, default SUTV will be 2.0 VDC.

7.1.5.4 Set SLTV per Fig. 6 if known. If not known, default SLTV will be 0.9 VDC.

7.1.6 Adjust power supply to test voltage per Fig. 6 if known. If not known, default test voltage will be 5 VDC.

7.1.7 Adjust to rising waveform when measuring T_{CBM} .

7.1.8 Adjust to falling waveform when measuring T_{CBB} .

7.2 In Process Test (T_{CBM}):

7.2.1 Activate and release switch with test probe at the predetermined force (7.1.6) at a cycling rate not to exceed 3 cycles per second.

7.2.2 Record T_{CBM} (see Fig. 2) from oscilloscope display.

7.2.3 Repeat 7.2.1 – 7.2.3 four more times.

7.3 In Process Test (T_{CBB}):

7.3.1 Activate and release switch with test probe at the predetermined force (7.1.6) at a cycling rate not to exceed 3 cycles per second.

7.3.2 Record T_{CBB} (see Fig. 1) from oscilloscope display.

7.3.3 Repeat 7.3.1 – 7.3.3 four more times.

6.2 Test Surface— flat, smooth, unyielding, and larger than switch under test.

6.3 Oscilloscope, with recording capabilities and power supply, or suitable contact bounce time measuring instrument.

6.4 Device, which will consistently move probe into and away from the switch at a controlled speed. Also capable of applying a specified force.

7. Procedure

7.1 Pretest Setup:

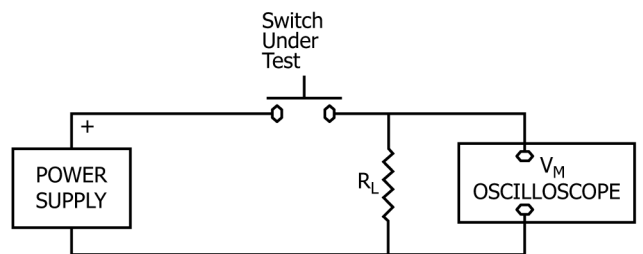

FIG. 5 Test Setup Option