



Designation: D4778 – 15

Standard Test Method for Determination of Corrosion and Fouling Tendency of Cooling Water Under Heat Transfer Conditions¹

This standard is issued under the fixed designation D4778; the number immediately following the designation indicates the year of original adoption or, in the case of revision, the year of last revision. A number in parentheses indicates the year of last reapproval. A superscript epsilon (ϵ) indicates an editorial change since the last revision or reapproval.

1. Scope

1.1 This test method provides directions for fabricating and operating a test apparatus to simultaneously monitor the corrosion and fouling tendency of real and pilot cooling water systems under heat transfer conditions.

1.2 Interpretation of the results of this test method must be left to the investigator. Many variables are involved which may not be easily controlled or fully understood. Variations in design and operating conditions may produce results that are not comparable from unit to unit.

1.3 The values stated in inch-pound units are to be regarded as standard. The values given in parentheses are mathematical conversions to SI units that are provided for information only and are not considered standard.

1.4 *This standard does not purport to address all of the safety concerns, if any, associated with its use. It is the responsibility of the user of this standard to establish appropriate safety, health, and environmental practices and determine the applicability of regulatory limitations prior to use.*

1.5 *This international standard was developed in accordance with internationally recognized principles on standardization established in the Decision on Principles for the Development of International Standards, Guides and Recommendations issued by the World Trade Organization Technical Barriers to Trade (TBT) Committee.*

2. Referenced Documents

2.1 *ASTM Standards:*²

[D1129 Terminology Relating to Water](#)

[D2331 Practices for Preparation and Preliminary Testing of Water-Formed Deposits](#)

¹ This test method is under the jurisdiction of ASTM Committee D19 on Water and is the direct responsibility of Subcommittee D19.03 on Sampling Water and Water-Formed Deposits, Analysis of Water for Power Generation and Process Use, On-Line Water Analysis, and Surveillance of Water.

Current edition approved June 1, 2015. Published July 2015. Originally approved in 1988. Last previous edition approved in 2010 as D4778 – 10. DOI: 10.1520/D4778-15.

² For referenced ASTM standards, visit the ASTM website, www.astm.org, or contact ASTM Customer Service at service@astm.org. For *Annual Book of ASTM Standards* volume information, refer to the standard's Document Summary page on the ASTM website.

[D2777 Practice for Determination of Precision and Bias of Applicable Test Methods of Committee D19 on Water](#)

[G1 Practice for Preparing, Cleaning, and Evaluating Corrosion Test Specimens](#)

[G16 Guide for Applying Statistics to Analysis of Corrosion Data](#)

3. Terminology

3.1 *Definitions:*

3.1.1 For definitions of terms used in this standard, refer to Terminology [D1129](#).

3.2 *Definitions of Terms Specific to This Standard:*

3.2.1 *corrosion, n*—the deterioration of the metal by reaction with its environment.

3.2.2 *fouling, n*—deposition of organic matter or inorganic matter, or both, on heat transfer surfaces that result in the loss of heat transfer efficiency.

3.2.3 *heat flux, n*—heat transfer per unit area per unit time.

4. Summary of Test Method

4.1 Water from the system to be tested flows across a heated tube of the desired metallurgy at a constant flow rate and heat flux. Corrosion rate is determined by weight loss while fouling tendency is determined by the deposit weight.

5. Significance and Use

5.1 Deposits on heat transfer surfaces reduce efficiency of the heat exchanger affected. A method for easily determining the corrosion and fouling tendency of a particular water under heat transfer conditions will allow the evaluation of changes in the various system variables such as heat flux, flow velocity, metallurgy, cycles-of-concentration, and treatment schemes on heat exchanger performance.

6. Apparatus (Fig. 1)

6.1 *Test Specimen*—A metal tube of $\frac{3}{8}$ or $\frac{1}{2}$ in. (9.5 or 12.5 mm) outside diameter with sufficient inside diameter to snugly accommodate the cartridge heater. The tube should be cut to a length sufficient to extend $\frac{1}{2}$ in. (12.5 mm) from each end of the test assembly. If both corrosion and deposition are to be determined, metallurgy of the test specimen should match that of the heat exchanger being modeled.

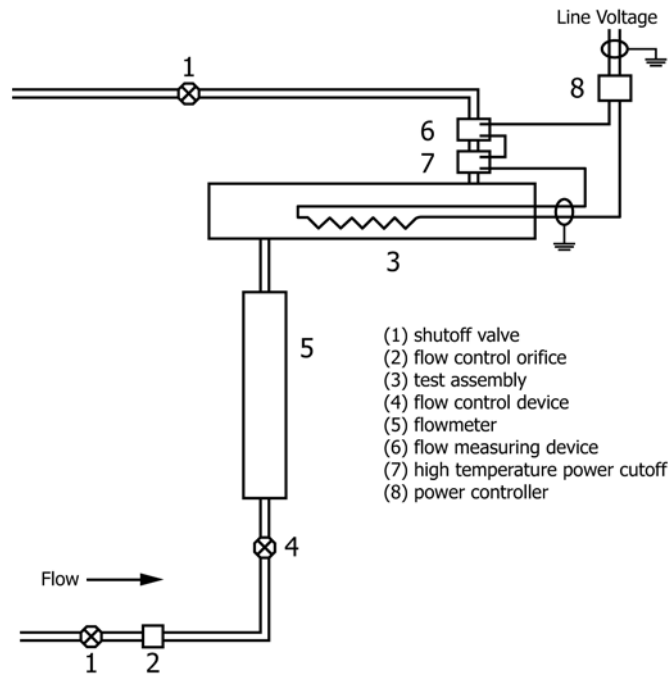

- (1) shutoff valve
- (2) flow control orifice
- (3) test assembly
- (4) flow control device
- (5) flowmeter
- (6) flow measuring device
- (7) high temperature power cutoff
- (8) power controller

NOTE 1—All pipe is threaded 1 in. (25 mm) PVC. Heater should be fused and grounded in accordance with local electrical codes.

FIG. 1 Test Apparatus and Parts List

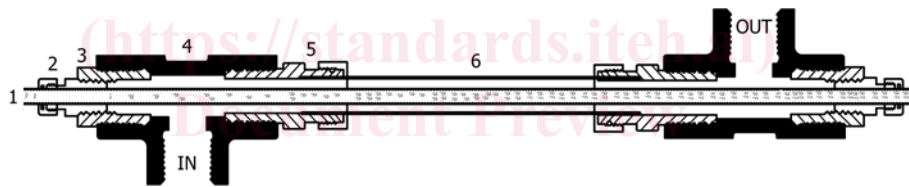

Parts List:

- | | |
|--|---|
| (1) test specimen | (6) acrylic tube, 10 in. (25 cm) long by 1 in. (25 mm) outside Diameter |
| (2) tube fitting; nylon (no metal parts) | (7) Cartridge type heater (not shown) |
| (3) reducing bushing, PVC | |
| (4) tee, 1 in. (25 mm) PVC | |
| (5) tube fitting, 1 in. (25 mm) tube by 1 in. (25 mm) male pipe thread stainless steel | |

FIG. 2 Test Assembly and Parts List

6.2 *Cartridge Heater*—A $\frac{1}{4}$ or $\frac{3}{8}$ in. (6.2 or 9.5 mm) diameter. Heated surface should be 4 to 8 in. (10 to 20 cm) long with a minimum power rating sufficient to provide 110 % of the heat load required (see Eq 7, 8.2.2). The heater should have an unheated section of sufficient length to allow the center of the heated section to be placed consistently in the center of the test specimen.

6.3 *Power Controller*—A device to set and control the power to the heater, such as a variable transformer, is used to adjust the heat flux in order to maintain the surface temperature of the test specimen consistent with the heat exchanger being modeled. The power controller should be rated to maintain at least 120 %, but not more than 400 % of the power required.

6.4 *Flow Control*—A flow meter or a flow control device such as an orifice, or both, is recommended to maintain a consistent flow rate during the test period.

6.5 *Safety Equipment*—A pressure or flow sensor/controller is necessary to cut power to the heater in the event of a flow interruption. A high temperature cutoff is recommended for added protection.

6.6 *Test Assembly*—See Fig. 2.

7. Materials

7.1 *Vapor Phase Inhibitor Paper*—Envelopes constructed of vapor phase inhibitor paper.