



Designation: A757/A757M – 15

Standard Specification for Steel Castings, Ferritic and Martensitic, for Pressure- Containing and Other Applications, for Low-Temperature Service¹

This standard is issued under the fixed designation A757/A757M; the number immediately following the designation indicates the year of original adoption or, in the case of revision, the year of last revision. A number in parentheses indicates the year of last reappraisal. A superscript epsilon (ϵ) indicates an editorial change since the last revision or reappraisal.

This standard has been approved for use by agencies of the U.S. Department of Defense.

1. Scope*

1.1 This specification covers carbon and alloy steel castings for pressure-containing and other applications intended primarily for petroleum and gas pipelines in areas subject to low-ambient temperatures. Castings shall be heat treated by normalizing and tempering or liquid quenching and tempering. All classes are weldable under proper conditions. Hardenability of some grades may limit usable section size.

1.2 The values stated in either inch-pound units or SI units are to be regarded separately as standard. The values stated in each system are not exact equivalents; therefore, each system must be used independently of the other. Combining values from the two systems may result in non-conformance with the standard.

1.2.1 Unless the order specifies an “M” designation, the material shall be furnished to inch-pound units.

1.3 *This standard does not purport to address all of the safety concerns, if any, associated with its use. It is the responsibility of the user of this standard to establish appropriate safety and health practices and determine the applicability of regulatory limitations prior to use.*

2. Referenced Documents

2.1 *ASTM Standards:*²

A488/A488M Practice for Steel Castings, Welding, Qualifications of Procedures and Personnel

A703/A703M Specification for Steel Castings, General Requirements, for Pressure-Containing Parts

A985/A985M Specification for Steel Investment Castings

¹ This specification is under the jurisdiction of ASTM Committee A01 on Steel, Stainless Steel and Related Alloys and is the direct responsibility of Subcommittee A01.18 on Castings.

Current edition approved July 1, 2015. Published August 2015. Originally approved in 1978. Last previous edition approved in 2010 as A757/A757M – 10. DOI: 10.1520/A757_A757M-15.

² For referenced ASTM standards, visit the ASTM website, www.astm.org, or contact ASTM Customer Service at service@astm.org. For *Annual Book of ASTM Standards* volume information, refer to the standard’s Document Summary page on the ASTM website.

General Requirements, for Pressure-Containing Parts
A1067/A1067M Specification for Test Coupons for Steel Castings

2.2 *American Society of Mechanical Engineers:*³
ASME Boiler and Pressure Vessel Code

2.3 *Manufacturers Standardization Society of the Valve and Fittings Industry Standards:*⁴

MSS SP-55 Quality Standard for Steel Castings for Valves, Flanges, Fittings, and Other Piping Components - Visual Method for Evaluation of Surface Irregularities

3. Terminology

3.1 *Definitions:*

3.1.1 Definitions in Specification A703/A703M are applicable to this specification.

3.1.2 Definition of nominal thickness, T , applies to quenched and tempered castings with a thickness exceeding 2 in. [50 mm]. Nominal thickness, T , is the maximum thickness of the pressure-containing wall of the casting exclusive of padding added for directional solidification, flanges, appendages, and sections designated by the designer as non-critical.

4. General Conditions for Delivery

4.1 Except for investment castings, castings furnished to this specification shall be in accordance with the requirements of Specification A703/A703M, including any supplementary requirements that are indicated in the purchase order. Failure to comply with the general requirements of Specification A703/A703M constitutes nonconformance with this specification. In case of conflict between the requirements of this specification and Specification A703/A703M, this specification shall prevail.

³ Available from American Society of Mechanical Engineers (ASME), ASME International Headquarters, Three Park Ave., New York, NY 10016-5990, <http://www.asme.org>.

⁴ Available from Manufacturers Standardization Society of the Valve and Fittings Industry (MSS), 127 Park St., NE, Vienna, VA 22180-4602, <http://www.mss-hq.com>.

*A Summary of Changes section appears at the end of this standard

TABLE 1 Chemical Requirements (Maximum Percent Unless Range is Given)

Grade	A1Q	A2Q	B2N B2Q	B3N B3Q	B4N B4Q	C1Q	D1N1 D1Q1 D1N2 D1Q2 D1N3 D1Q3	E1Q	E2N, E2Q	E3N
Type	Carbon	Carbon-Manganese	2½ Nickel	3½ Nickel	4½ Nickel	Nickel Molybdenum	Chromium Molybdenum	Nickel Chromium Molybdenum	Nickel Chromium Molybdenum	Martensitic Chromium Nickel
Carbon	0.30	0.25 ^A	0.25	0.15	0.15	0.25	0.20	0.22	0.20	0.06
Manganese	1.00	1.20 ^A	0.50/0.80	0.50/0.80	0.50/0.80	1.20	0.40/0.80	0.50/0.80	0.40/0.70	1.00
Phosphorus	0.025	0.025	0.025	0.025	0.025	0.025	0.025	0.025	0.020	0.030
Sulfur	0.025	0.025	0.025	0.025	0.025	0.025	0.025	0.025	0.020	0.030
Silicon	0.60	0.60	0.60	0.60	0.60	0.60	0.60	0.60	0.60	1.00
Nickel	—	—	2.0/3.0	3.0/4.0	4.0/5.0	1.5/2.0	—	2.5/3.5	2.75/3.90	3.5/4.5
Chromium	—	—	—	—	—	—	2.0/2.75	1.35/1.85	1.50/2.0	11.5/14.0
Molybdenum	—	—	—	—	—	0.15/0.30	0.90/1.20	0.35/0.60	0.40/0.60	0.40/1.0
Specified Residual Elements:										
Vanadium	0.03	0.03	0.03	0.03	0.03	0.03	0.03	0.03	0.03	—
Copper	0.50	0.50	0.50	0.50	0.50	0.50	0.50	0.50	0.50	0.50
Nickel	0.50	0.50	—	—	—	—	0.50	—	—	—
Chromium	0.40	0.40	0.40	0.40	0.40	0.40	—	—	—	—
Molybdenum	0.25	0.25	0.25	0.25	0.25	—	—	—	—	—
Tungsten	—	—	—	—	—	—	0.10	—	0.10	0.10
Total residuals (maximum %) ^B	1.00	1.00	1.00	1.00	1.00	1.00	1.00	0.70	0.70	0.50

^A For each 0.01 % of reduction in carbon below the maximum specified, an increase of 0.04 % manganese over the maximum specified will be permitted up to 1.40 %.

^B Total residuals includes phosphorus and sulfur.

iTeh Standards

4.2 Steel investment castings furnished to this specification shall conform to the requirements of Specification **A985/A985M**, including any supplementary requirements that are indicated in the purchase order. Failure to comply with the general requirements of Specification **A985/A985M** constitutes nonconformance with this specification. In case of conflict between the requirements of this specification and Specification **A985/A985M**, **A985/A985M** shall prevail.

5. Ordering Information

5.1 Orders for material to this specification should include the following, as required, to describe the material adequately:

5.1.1 Quantity,

5.1.2 ASTM designation and date of issue,

5.1.3 Grade designation (**Table 1**),

5.1.4 Description of casting by part, pattern, or drawing number. (Dimensional tolerances and machined surfaces should be indicated on the casting drawing).

5.1.5 Options in the specification,

5.1.6 Whether the castings are to be produced using investment casting process, and

5.1.7 Supplementary requirements desired, if any, including standards of acceptance.

6. Materials and Manufacture

6.1 *Melting Process*—The steel shall be made by the electric furnace process or other primary processes approved by the purchaser. The primary melting may incorporate separate degassing or refining and may be followed by secondary melting.

6.2 *Heat Treatment*:

6.2.1 All castings shall be heat treated by either normalizing and tempering or quenching and tempering. Tempering temperature shall be 1100°F [595°C] minimum, except grades B4N and B4Q, which shall be tempered at 1050°F [565°C] minimum.

6.2.2 E3N castings shall be heat treated by heating to 1850°F [1010°C] minimum, and air cooling to 200°F [95°C] maximum before any optional intermediate temper, but shall cool to 100°F [40°C] maximum before the final temper, which shall be between 1050 and 1150°F [565 and 620°C].

6.2.3 Furnace temperatures for heat treating shall be controlled by pyrometers.

6.2.4 Castings shall be allowed to cool below the transformation range directly after pouring and solidification before they are reheated for normalizing or liquid quenching.

7. Chemical Composition

7.1 The steel shall be in accordance with the requirements as to chemical composition prescribed in **Table 1**.

8. Tensile Requirements

8.1 Steel used for the castings shall conform to the requirements as to the tensile properties prescribed in **Table 2**.

9. Impact Requirements

9.1 Impact properties shall be determined on each heat by testing a set of three Charpy V-notch specimens. The bar from which the impact specimens are machined shall be prepared in accordance with Section 12. The longitudinal axis of the Charpy specimens shall be parallel to the longitudinal axis of the tensile bar.

TABLE 2 Tensile Requirements

Grade	Heat Treatment ^{A, B}	Tensile Strength, ^C min, ksi [MPa]	Yield Strength (0.2 % offset), min, ksi [MPa]	Elongation in 2 in. [50 mm], min, %	Reduction of Area, min, %
A1Q	QT	65 [450]	35 [240]	24	35
A2Q	QT	70 [485]	40 [275]	22	35
B2N, B2Q	NT/QT ^D	70 [485]	40 [275]	24	35
B3N, B3Q	NT/QT	70 [485]	40 [275]	24	35
B4N, B4Q	NT/QT	70 [485]	40 [275]	24	35
C1Q	QT	75 [515]	55 [380]	22	35
D1N1, D1Q1	NT/QT	85 [585] 115 [795]	55 [380]	20	35
D1N2, D1Q2	NT/QT	95 [655] 125 [860]	75 [515]	18	35
D1N3, D1Q3	NT/QT	105 [725] 135 [930]	85 [585]	15	30
E1Q	QT	90 [620]	65 [450]	22	40
E2N1, E2Q1	NT/QT	90 [620] 120 [825]	70 [485]	18	35
E2N2, E2Q2	NT/QT	105 [725] 135 [930]	85 [585]	15	30
E2N3, E2Q3	NT/QT	115 [795] 145 [1000]	100 [690]	13	30
E3N	NT	110 [760]	80 [550]	15	35

^A QT = Quenched and tempered.

^B NT = Normalized and tempered.

^C Minimum ksi (MPa), unless range is given.

^D NT/QT indicates that either a normalized and tempered or quenched and tempered heat treatment may be used.

9.2 Test temperature and absorbed energy requirements for the grade shall be as specified in **Table 3**. Impact properties at temperatures other than specified in **Table 3** shall be agreed upon between the manufacturer and the purchaser and Supplementary Requirement S8 shall be specified. The average energy value of three specimens shall not be less than the minimum average specified, with only one value permitted below the minimum average specified and this value not permitted to fall below the minimum specified for a single specimen. Supplementary Requirement S52 may be specified if lateral expansion or percent shear area, or both, are desired by the purchaser.

9.3 Impact properties shall also be determined on both the heat-affected zone of the base metal and the weld metal of the welding procedure qualification test. Test temperature, energy absorption, specimen type, and test method shall be the same as specified for the base material.

9.3.1 *Coupons Representing the Weld Deposits*—Impact specimens shall be located so that the longitudinal axis of the specimen is at least one fourth of the thickness of the weld test plate, t , from the surface of the test assembly and is transverse to the longitudinal axis of the weld with the area of the notch located in the weld metal. The length of the notch of the Charpy specimen shall be normal to the surface of the weld (see **Fig. 1**).

9.3.2 *Coupons Representing the Heat-Affected Zone*:

9.3.2.1 Impact specimens in test plate thicknesses greater than $\frac{5}{8}$ in. [16 mm] shall be from coupons removed from a location as near as practical to a point midway between the surface and center thickness. Heat-affected zone coupons for impact specimens shall be taken transverse to the weld and etched to define the heat-affected zone. The notch shall be cut

normal to the material surface in the heat-affected zone to include as much heat-affected zone as possible in the resulting fracture (see **Fig. 2**).

9.3.2.2 Where the material thickness permits, the axis of a specimen may be inclined to allow the root of the notch to align parallel to the fusion line (see **Fig. 2**).

9.4 Test temperature and impact values for section thickness in excess of those specified in **Table 3** may be agreed upon between the manufacturer and the purchaser, in which case, Supplementary Requirement S8 shall be specified. Castings shall be marked with this test temperature in accordance with **14.1**.

10. Workmanship, Finish, and Appearance

10.1 Castings shall conform to the shapes, tolerances, and sizes indicated by patterns or drawings submitted by the purchaser.

10.2 The castings shall not be peened, plugged, or impregnated to stop leaks or disguise rejectable indications.

11. Quality

11.1 The surface of the casting shall be examined visually and shall be free of adhering sand, scale, cracks, and hot tears. Other surface discontinuities shall meet the visual acceptance standards specified in the order. Visual Method MSS SP-55 or other visual standards may be used to define acceptable surface discontinuities and finish. Unacceptable visual surface discontinuities shall be removed and their removal verified by visual examination of the resultant cavities. When methods involving high temperatures are used in the removal of discontinuities, the casting shall be preheated to at least the minimum temperatures in **Table 4**.

TABLE 3 Charpy V-Notch Energy Requirements for Standard Size (10 mm by 10 mm) Specimens^A

Grade	Heat Treatment ^{B,C}	Effective Section Size, max. in. [mm]	Test Temperature		Energy value, ft-lbf [J], min value for two specimens and min average of three specimens	Energy Value, ft-lbf [J], min for single specimen
			°F	[°C]		
A1Q	QT	1¼ [32]	-50	[-46]	13 [17]	10 [14]
A2Q	QT	3 [75]	-50	[-46]	15 [20]	12 [16]
B2N, B2Q	NT/QT ^D	5 [125]	-100	[-73]	15 [20]	12 [16]
B3N, B3Q	NT/QT	1¼ [32]	-150	[-101]	15 [20]	12 [16]
B4N, B4Q	NT/QT	1¼ [32]	-175	[-115]	15 [20]	12 [16]
C1Q	QT	5 [125]	-50	[-46]	15 [20]	12 [16]
D1N1, D 1Q1	NT/QT	^E	^E	^E	^E	^E
D1N2, D 1Q2	NT/QT	^E	^E	^E	^E	^E
D1N3, D 1Q3	NT/QT	^E	^E	^E	^E	^E
E1Q	QT	^E	-100	[-73]	30 [41]	25 [34]
E2N1, E 2Q1	NT/QT	5 [125]	-100	[-73]	30 [41]	25 [34]
E2N2, E 2Q2	NT/QT	1¼ [32]	-100	[-73]	20 [27]	15 [20]
E2N3, E 2Q3	NT/QT	1¼ [32]	-100	[-73]	15 [20]	12 [16]
E3N	NT	1¼ [32]	-100	[-73]	20 [27]	15 [20]

^A Hardenability and residual elements (primarily P & S levels) in some of the grades may limit the maximum section size in which these impact values can be obtained.
^B QT = Quenched and tempered.
^C NT = Normalized and tempered.
^D NT/QT indicates that either a normalized and tempered or quenched and tempered heat treatment may be used.
^E Requirements shall be subject to agreement between the manufacturer and the purchaser.

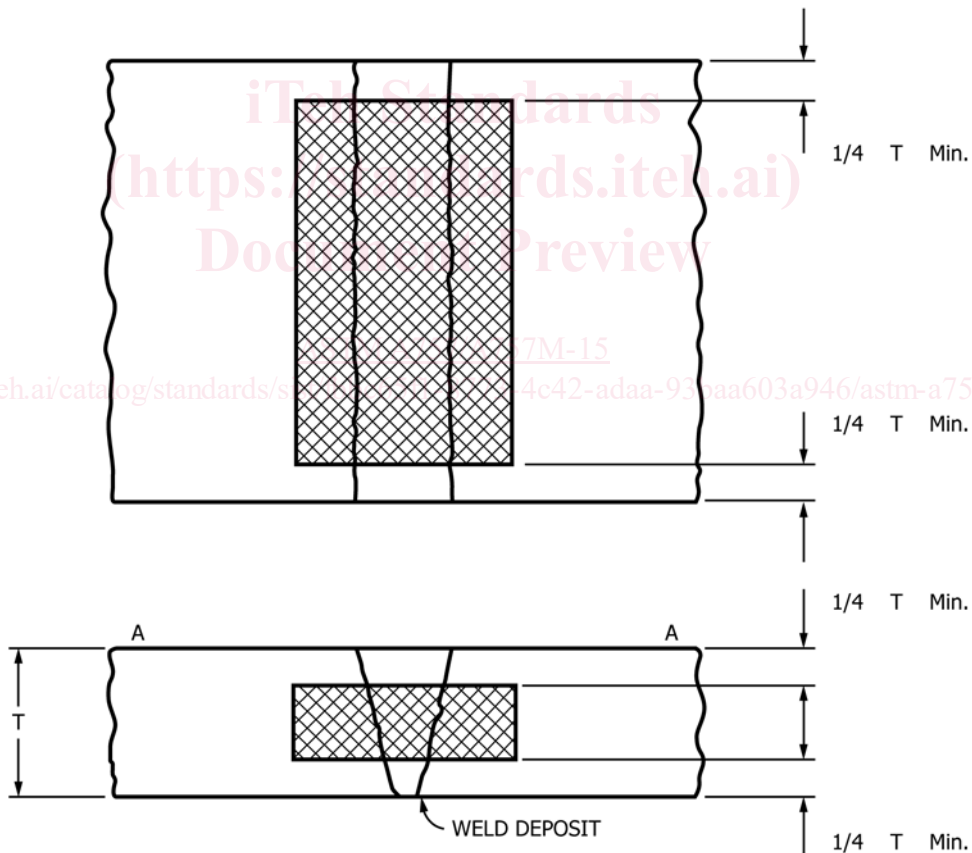

FIG. 1 Charpy V-Notch Specimen Must Be Within Cross-Hatched Zone With Notch in the Weld Metal Perpendicular to Surface A-A