



Designation: D1560 – 15

Standard Test Methods for Resistance to Deformation and Cohesion of Asphalt Mixtures by Means of Hveem Apparatus¹

This standard is issued under the fixed designation D1560; the number immediately following the designation indicates the year of original adoption or, in the case of revision, the year of last revision. A number in parentheses indicates the year of last reapproval. A superscript epsilon (ϵ) indicates an editorial change since the last revision or reapproval.

1. Scope

1.1 These test methods cover the determination of (1) the resistance to deformation of compacted asphalt mixtures by measuring the lateral pressure developed when applying a vertical load by means of the Hveem stabilometer and (2) the cohesion of compacted asphalt mixtures by measuring the force required to break or bend the sample as a cantilever beam by means of the Hveem cohesiometer.²

1.2 The values stated in inch-pound units are to be regarded as standard, with the exception that the steel shot flow rate for the cohesiometer is expressed in g/min units. The values given in parentheses are mathematical conversions to SI units that are provided for information only and are not considered standard.

1.3 The text of this standard references notes and footnotes which provide explanatory material. These notes and footnotes (excluding those in tables and figures) shall not be considered as requirements of the standard.

1.4 *This standard does not purport to address all of the safety concerns, if any, associated with its use. It is the responsibility of the user of this standard to establish appropriate safety and health practices and determine the applicability of regulatory limitations prior to use.*

2. Referenced Documents

2.1 ASTM Standards:³

D1561 Practice for Preparation of Bituminous Mixture Test Specimens by Means of California Kneading Compactor

¹ These test methods are under the jurisdiction of ASTM Committee D04 on Road and Paving Materials and are the direct responsibility of Subcommittee D04.20 on Mechanical Tests of Asphalt Mixtures.

Current edition approved July 1, 2015. Published August 2015. Originally approved in 1958. Last previous edition approved in 2009 as D1560 – 09a. DOI: 10.1520/D1560-15.

² A more detailed description of the procedures for performing the tests is available on request from the California Dept. of Transportation, 5900 Folsom Blvd., Sacramento, CA 95819. Also available is a procedure containing details regarding the operation and calibration of the stabilometer and the replacement of the stabilometer diaphragm.

³ For referenced ASTM standards, visit the ASTM website, www.astm.org, or contact ASTM Customer Service at service@astm.org. For *Annual Book of ASTM Standards* volume information, refer to the standard's Document Summary page on the ASTM website.

D3666 Specification for Minimum Requirements for Agencies Testing and Inspecting Road and Paving Materials

2.2 California Department of Transportation Standards: Test 366 Method of Test for Stabilometer Value²

3. Significance and Use

3.1 The results of the deformation and cohesion tests can be used for specification purposes or for mix design purposes, or both. For example, these values can be used for specification compliance testing of aggregate properties. They can also be used for specification compliance testing of the mix. The cohesion test is sometimes used for fine mixes such as sand mixes wherein cohesion, or tensile strength, is of major or primary importance. The cohesion test is also sometimes used for the design of cold mixes containing emulsified asphalt.

NOTE 1—The quality of the results produced by this standard are dependent on the competence of the personnel performing the procedure and the capability, calibration, and maintenance of the equipment used. Agencies that meet the criteria of Specification D3666 are generally considered capable of competent and objective testing/sampling/inspection/etc. Users of this standard are cautioned that compliance with Specification D3666 alone does not completely assure reliable results. Reliable results depend on many factors; following the suggestions of Specification D3666 or some similar acceptable guideline provides a means of evaluating and controlling some of those factors.

RESISTANCE TO DEFORMATION

4. Apparatus

4.1 **Stabilometer**—The Hveem stabilometer (Fig. 1 and Fig. 2) is a triaxial testing device consisting essentially of a rubber sleeve within a metal cylinder containing a liquid which registers the horizontal pressure developed by a compacted test specimen as a vertical load is applied.

4.2 **Testing Machine**—A compression testing machine having a minimum capacity of 10 000 lbf (44.5 kN). Fig. 3 shows the stabilometer in a testing machine.

4.3 **Test Specimen Push-Out Device**—A device, to push the specimen out of the mold.

4.4 **Oven**—An oven capable of maintaining a temperature of $140 \pm 5^\circ\text{F}$ ($60 \pm 3^\circ\text{C}$).

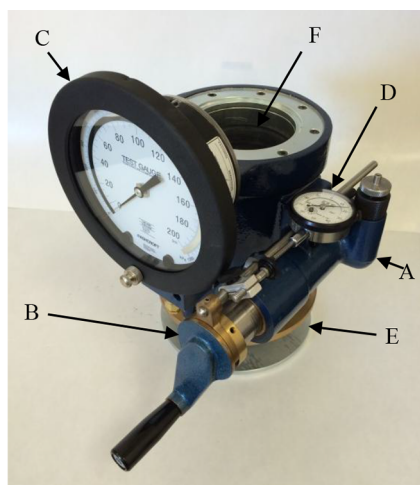

A—Air cell.
 B—Displacement pump.
 C—200-psi pressure gauge.
 D—Ames dial.
 E—Base adjustment nut.
 F—Bottom of upper tapered ring.

FIG. 1 Hveem Stabilometer

4.5 *Calibration Cylinder*—A hollow metal cylinder 4.000 ± 0.005 in. (101.6 ± 0.13 mm) in outside diameter by 5.50 ± 0.25 in. (140 ± 6.4 mm) high (for calibration purposes).

4.6 *Rubber Bulb*—For introducing air into the stabilometer.

4.7 *Follower*—One solid wall metal follower 3.985 in. (101.2 mm) in diameter by 5½ in. (140 mm) high (see Fig. 4 and Fig. 5).

5. Test Specimens

5.1 Test specimens shall be mixed and compacted in accordance with those procedures normally used. The procedure described in Practice D1561 is a suitable procedure.

5.2 Test specimens shall be 4 in. (102 mm) in diameter. The height of the test specimens should be 2.5 ± 0.5 in. (64 ± 3 mm). If this height cannot be obtained, the stabilometer value shall be corrected as indicated by Fig. 6.

6. Adjustment of Stabilometer

6.1 Adjust the stabilometer base so that the distance from the bottom of the upper tapered ring (see Fig. 1) to the top of the base is 3.5 in. (89 mm).

6.2 Place the calibration cylinder (preheated to 140°F (60°C)) in place in the stabilometer. Seat it firmly on the stage, hold it in place with either the hand or a vertical load of 100 lbf (0.45 kN) in the testing machine, and apply a horizontal pressure of exactly 5 psi (34.5 kPa). When applying the 5 psi (34.5 kPa) pressure, always start below or drop below this value, then bring the pressure up to 5 psi (34.5 kPa) and gently tap the dial to remove any slack in the system. Adjust the turns indicator dial to zero. Turn the pump handle at an approximate rate of two turns per second until the stabilometer dial reads 100 psi (689 kPa). The turns indicator dial shall read 2.00 ±

0.05 turns. If it does not, the air in the cell must be adjusted. Remove or add air by means of the valve and the rubber bulb, then repeat the displacement measurement. Continue to adjust the amount of air in the system until the proper number of turns is obtained. Release the horizontal pressure and remove the calibration cylinder.

6.3 With the stabilometer and stage base in position on the platen, adjust the testing machine so that the load will be applied at the rate of 0.05 in. (1.3 mm) /min.

7. Procedure

7.1 Heat the specimen to be tested in an oven at 140 ± 5°F (60 ± 3°C) for 3 to 4 h.

NOTE 2—Bring the specimen to room temperature in the case in which it is desired to test with whatever moisture may be present in the mixture.

7.2 Transfer the compacted specimen from the mold to the stabilometer by means of a suitable push-out device. Make sure that the specimen goes into the stabilometer straight, with the tamped end up, and that it is firmly seated level on the base. Place the follower on top of the specimen and apply a horizontal pressure until exactly 5 psi (34.5 kPa) is recorded on the stabilometer gauge. If the testing machine has a spherically seated type of upper head, the locking shims used during the fabrication of the test specimen must be removed before performing the stabilometer test. Start the vertical movement of the press (speed of 0.05 in. (1.3 mm) /min) and record the stabilometer gauge readings when the vertical load is 3000, 5000, and 6000 lbf (13.4, 22.3, and 26.7 kN). Stop the vertical movement of the press when the total load reaches 6000 lbf (26.7 kN). Immediately reduce the vertical load to 1000 ± 100 lbf (4.45 ± 0.45 kN), and then adjust the horizontal pressure to 5 psi (34.5 kPa). This will result in a further reduction of the vertical load to less than 1000 lbf (4.45 kN). This is normal and no compensation need be made. Measure the number of turns of the pump handle required to raise the horizontal pressure from 5 to 100 psi (34.5 to 689 kPa) with the specimen in place. Turn the pump handle at approximately two turns per second when applying this pressure. The number of turns measured is the displacement reading, *D*. In measuring the displacement, the vertical load will increase and at times exceed 1000 lbf (4.45 kN). As before, these changes in load are characteristic and no adjustment or compensation is required.

8. Calculation

8.1 Determine the stabilometer value of the specimen as follows:

$$S = \frac{22.2}{[(P_h \cdot D)/(P_v - P_h)] + 0.222} \quad (1)$$

where:

- S* = stabilometer value,
- P_h* = horizontal pressure for corresponding *P_v* in psi (or kPa),
- D* = displacement of specimen, and
- P_v* = vertical pressure (typically the 400 psi (2800 kPa) being applied when the vertical load is 5000 lbf (22.3 kN).

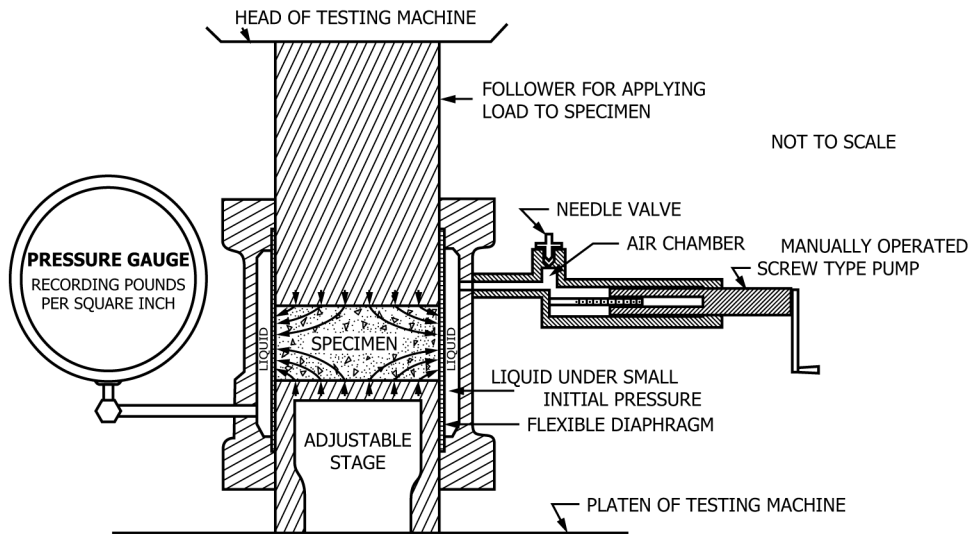

NOTE 1—The specimen is given lateral support by the flexible sidewall, which transmits horizontal pressure to the liquid. The magnitude of the pressure can be read on the gauge.

FIG. 2 Diagrammatic Sketch of the Hvem Stabilometer



FIG. 3 Hvem Stabilometer Placed in the Testing Machine



FIG. 4 Specimen Follower

9. Report

9.1 Report the following information:

- 9.1.1 Stabilometer value,
- 9.1.2 Test temperature, and
- 9.1.3 Asphalt content.