



Designation: **D6479—12 D6479 – 15**

Standard Test Method for Determining the Edgcomb Resistance of Woven Fabrics Used in Inflatable Restraints¹

This standard is issued under the fixed designation D6479; the number immediately following the designation indicates the year of original adoption or, in the case of revision, the year of last revision. A number in parentheses indicates the year of last reapproval. A superscript epsilon (ϵ) indicates an editorial change since the last revision or reapproval.

1. Scope

1.1 This test method covers the procedures for determining the resistance to edgcombing of a woven fabric used in inflatable restraints.

1.2 Procedures and apparatus other than those stated in this standard may be used by agreement of purchaser and supplier with the specific deviations from the standard practice acknowledged in the report.

1.3 The values stated in SI units are to be regarded as standard. No other units of measurement are included in this standard.

1.4 *This standard does not purport to address all of the safety concerns, if any, associated with its use. It is the responsibility of the user of this standard to establish appropriate safety and health practices and determine the applicability of regulatory limitations prior to use.*

2. Referenced Documents

2.1 *ASTM Standards:*²

[D1776 Practice for Conditioning and Testing Textiles](#)

[D123 Terminology Relating to Textiles](#)

[D2904 Practice for Interlaboratory Testing of a Textile Test Method that Produces Normally Distributed Data](#) (Withdrawn 2008)³

[D2906 Practice for Statements on Precision and Bias for Textiles](#) (Withdrawn 2008)³

[D5035 Test Method for Breaking Force and Elongation of Textile Fabrics \(Strip Method\)](#)

[D5822 Test Method for Determining Seam Strength in Inflatable Restraint Cushions](#)

[D6799 Terminology Relating to Inflatable Restraints](#)

[E691 Practice for Conducting an Interlaboratory Study to Determine the Precision of a Test Method](#)

3. Terminology

3.1 For all terminology relating to D13.20, Inflatable restraints, refer to Terminology [D6799](#).

3.1.1 The following terms are relevant to this standard: edgcombing, inflatable restraint, seam slippage, yarn slippage

3.2 For all other terms related to textiles, see Terminology [D123](#).

3.3 *Definitions:*

3.4 For definitions of other terms used in this standard, refer to Terminology [D123](#) and Terminology [D6799](#).

4. Summary of Test Method

4.1 One end of a test specimen is clamped within one jaw of a CRE tensile testing machine and a special fixture pierces a row of equally spaced needle holes through the opposite end of the specimen. In accordance with Test Method [D5035](#), a tensile force is applied to the specimen until rupture occurs. The measurement of the force required to cause rupture is the measurement of edgcomb resistance.

¹ This test method is under the jurisdiction of ASTM Committee [D13](#) on Textiles and are the direct responsibility of Subcommittee [D13.20](#) on Inflatable Restraints. Current edition approved July 1, 2012/July 1, 2015. Published August 2012/September 2015. Originally approved in 1999. Last previous edition approved in 2011/2012 as [D6479—11](#)/[D6479 – 12](#). DOI: [10.1520/D6479-12](#).10.1520/D6479-15.

² For referenced ASTM standards, visit the ASTM website, [www.astm.org](#), or contact ASTM Customer Service at [service@astm.org](#). For *Annual Book of ASTM Standards* volume information, refer to the standard's Document Summary page on the ASTM website.

³ The last approved version of this historical standard is referenced on [www.astm.org](#).

5. Significance and Use

5.1 A measurement of a fabric's edgecomb resistance indicates the relative tendency of a fabric to pull apart under seam stress or similar action. The related concepts of yarn slippage and seam slippage are limited to sewn seams, whereas the measurement of edgecomb resistance is made at the edge of a cut part in the absence of a sewn seam. The absence of a sewn seam in this test method eliminates the effect that a particular stitch might have on the tendency of a yarn to slip near an edge of a cut part

5.2 This test method is useful for material design evaluations in such applications as airbags in which seam stress is a major concern.

5.3 This method may be used as a complement to Test Method [D5822](#).

6. Apparatus

6.1 *Tensile Testing Machine*—A constant-rate-of-extension (CRE) type, that is designed for the tensile forces anticipated, that is operated at a rate of 200 ± 10 mm/min, that has a force range selected such that the anticipated break occurs between 10 and 90 % of full scale load, and that has jaws and grip faces as agreed upon by purchaser and supplier.

6.2 *Clamps*, jaws with smooth, flat, parallel faces a minimum of 60 mm wide by 25 mm tall. The jaws may be padded or coated under the jaw face area and should be mounted in the upper position in the tensile testing machine.

6.3 *Fixture*, compatible with tensile tester, equipped with twelve equally spaced 1 mm diameter pins with sharp points, 8 mm in length and corresponding 1.5 mm diameter holes with a stop located 5 mm from the center of the holes ([Fig. 1](#)). The fixture should be properly centered with the upper clamps and their surfaces should be aligned (not twisted).

6.4 *Load Cell*, whose rated capacity is between 110 and 1000 % of expected stripping load. A2000 N load cell is generally used for inflatable restraints.

6.5 For inflatable restraints, all test equipment used in accordance with this test method shall be certified for calibration annually by an independent agency or equipment manufacturer whose results are traceable to National Institute of Science and Technology (NIST) or other national standards laboratory. The test parameters of the equipment shall be tested within the operating ranges covered in the cushion specification or equivalent document.

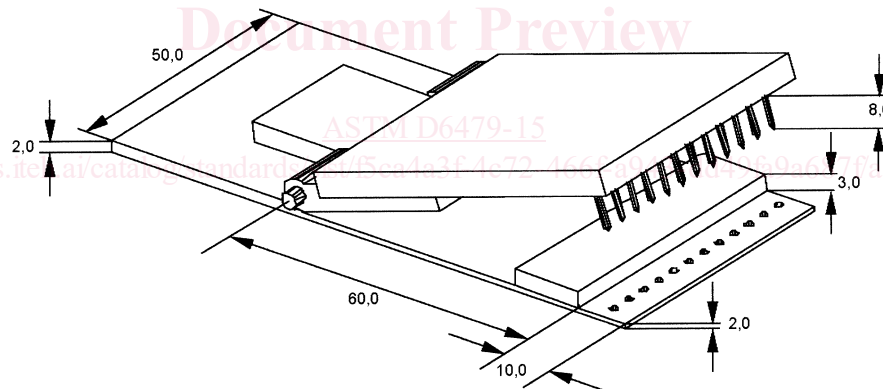

- Description:
- 50,0 mm total width for baseplate of the specimens holder
 - 70,0 mm total length for moveable arm of the specimens holder
 - 3,0 mm distance from centre of the first needle to edge of specimens holder
 - 4,0 mm distance between centres of the needles
 - 1,0 mm diameter of needles
 - 12 grounded needles
 - 8,0 mm length of visible needles
 - 10,0 mm total lock distance for specimens
 - 5,0 mm distance between centre of drillings to edge of specimen holder
 - 1,5 mm diameter of drillings at the base plate
 - Connection between specimens holder and testing device to be fitted due to the needs of the testing device

FIG. 1 Fixture

7. Sampling and Specimen Preparation

7.1 Edgecomb resistance testing is a destructive test. If used in conjunction with lot testing, sampling is required.

7.2 For acceptance testing the lot size is the number of rolls of fabric produced in one production day, or as specified in the applicable material specification.

7.3 From the end of each roll of fabric taken from the lot sample, cut a 1 m long, full width sample of fabric.

7.4 From the laboratory sample, select five test specimens each from the warp and fill directions (Fig. 2).

7.5 Without sealing or unraveling the edges, cut each specimen 50 ± 1 mm wide and 300 ± 5 mm long, with the long dimension parallel to the warp yarns for a warp-oriented test, and parallel to the fill yarns for a fill-oriented test. Specimen Cut:

7.5.1 Cut Edge Method:

7.5.1.1 Without sealing or unraveling the edges, cut each specimen 50 ± 1 mm wide and 300 ± 5 mm long, with the long dimension parallel to the warp yarns for a warp-oriented test, and parallel to the fill yarns for a fill-oriented test.

7.5.2 Ravel Edge Method:

7.5.2.1 Cut each specimen 60 ± 1 mm wide and 300 ± 5 mm long, with the long dimension parallel to the warp yarns for a warp-oriented test, and parallel to the fill yarns for a fill-oriented test.

7.5.2.2 Ravel each specimen to give a testing width of 50 ± 1 mm wide by removing an approximately equal number of yarns from each side.

7.6 A final cut should be made to the edge that is inserted into the edgecomb fixture to ensure a continuous full yarn is present.

8. Conditioning

8.1 Specimens for edgecomb resistance testing shall be conditioned at the standard atmosphere for testing textiles for at least 4 h prior to test in accordance with Test Method D1776.

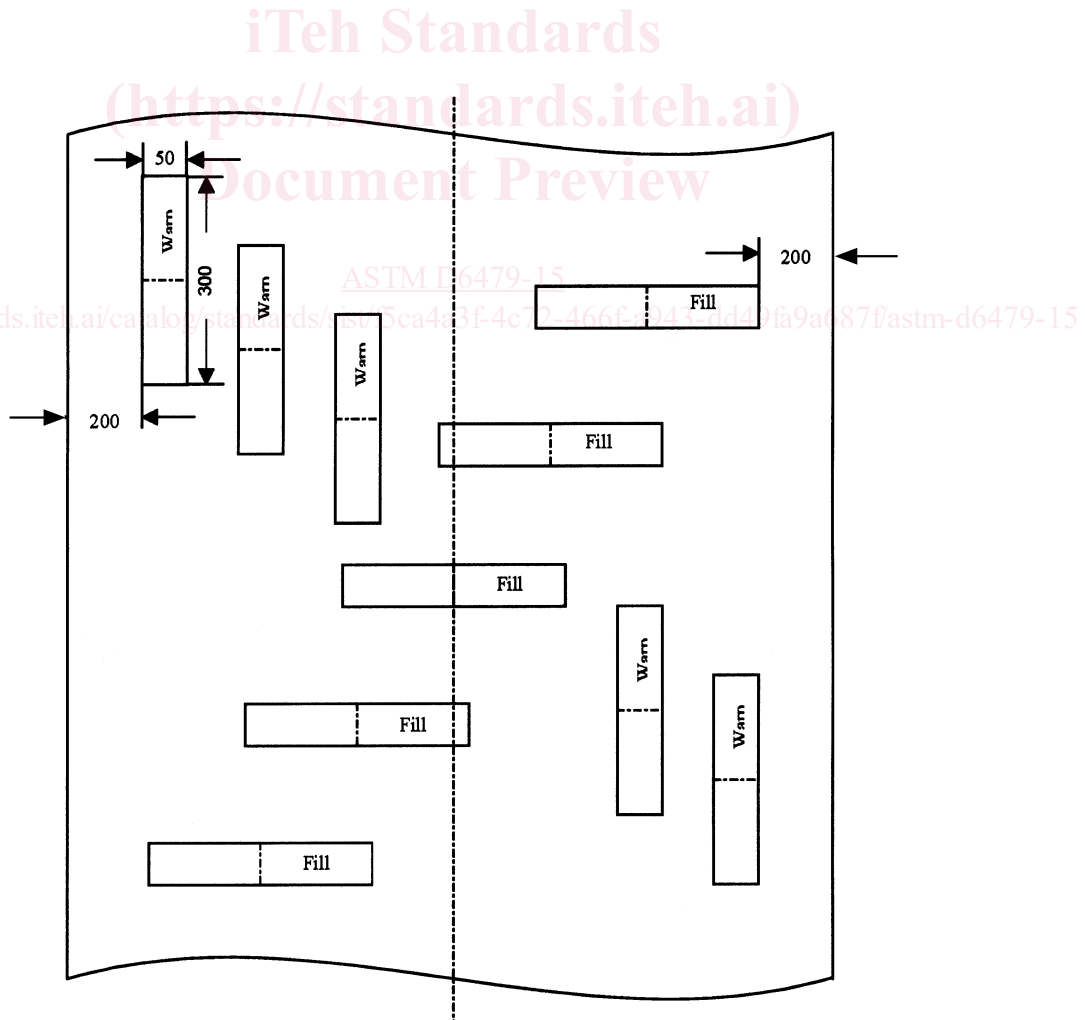

FIG. 2 Test Specimens