

# SLOVENSKI STANDARD

## SIST EN 1034-22:2005

01-november-2005

---

### Varnost strojev – Varnostne zahteve za načrtovanje in konstrukcijo strojev in opreme za izdelavo papirja – 22. del: Brusilniki za les

Safety of machinerie - Safety requirements for the design and construction of paper making and finishing machines - Part 22: Wood Grinders

Sicherheit von Maschinen - Sicherheitstechnische Anforderungen an Konstruktion und Bau von Maschinen der Papierherstellung und Ausrüstung - Teil 22: Holzschleifer

Sécurité des machines - Prescriptions de sécurité pour la conception et la construction de machines de fabrication et de finition du papier - Partie 22 : Défibreurs

<https://standards.iteh.ai/catalog/standards/sist/8ae39b8f-6bee-4926-a47f-1cc088c22f72/sist-en-1034-22-2005>

**Ta slovenski standard je istoveten z: EN 1034-22:2005**

---

#### **ICS:**

13.110	Varnost strojev	Safety of machinery
21.020	Značilnosti in načrtovanje strojev, aparatov, opreme	Characteristics and design of machines, apparatus, equipment
85.100	Oprema za papirno industrijo	Equipment for the paper industry

**SIST EN 1034-22:2005**

**en**

**iTeh STANDARD PREVIEW**  
**(standards.iteh.ai)**

[SIST EN 1034-22:2005](#)

<https://standards.iteh.ai/catalog/standards/sist/8ae39b8f-6bee-4926-a47f-1cc088c22f72/sist-en-1034-22-2005>

EUROPEAN STANDARD  
NORME EUROPÉENNE  
EUROPÄISCHE NORM

**EN 1034-22**

June 2005

ICS 85.100

English version

**Safety of machinery - Safety requirements for the design and construction of paper making and finishing machines - Part 22: Wood Grinders**

Sécurité des machines - Prescriptions de sécurité pour la conception et la construction de machines de fabrication et de finition du papier - Partie 22 : Défibreurs

Sicherheit von Maschinen - Sicherheitstechnische Anforderungen an Konstruktion und Bau von Maschinen der Papierherstellung und Ausrüstung - Teil 22: Holzschleifer

This European Standard was approved by CEN on 21 April 2005.

CEN members are bound to comply with the CEN/CENELEC Internal Regulations which stipulate the conditions for giving this European Standard the status of a national standard without any alteration. Up-to-date lists and bibliographical references concerning such national standards may be obtained on application to the Central Secretariat or to any CEN member.

This European Standard exists in three official versions (English, French, German). A version in any other language made by translation under the responsibility of a CEN member into its own language and notified to the Central Secretariat has the same status as the official versions.

CEN members are the national standards bodies of Austria, Belgium, Cyprus, Czech Republic, Denmark, Estonia, Finland, France, Germany, Greece, Hungary, Iceland, Ireland, Italy, Latvia, Lithuania, Luxembourg, Malta, Netherlands, Norway, Poland, Portugal, Slovakia, Slovenia, Spain, Sweden, Switzerland and United Kingdom.



EUROPEAN COMMITTEE FOR STANDARDIZATION  
COMITÉ EUROPÉEN DE NORMALISATION  
EUROPÄISCHES KOMITEE FÜR NORMUNG

**Management Centre: rue de Stassart, 36 B-1050 Brussels**

## Contents

Page

Foreword.....	3
Introduction.....	4
1 Scope.....	4
2 Normative references.....	4
3 Terms and definitions.....	5
4 List of significant hazards.....	7
5 Safety requirements and/or measures.....	8
5.1 General.....	8
5.2 Feeding devices.....	8
5.3 Power transmission elements.....	9
5.4 Gate valves.....	9
5.5 Inspection holes, manholes.....	9
5.6 Risk of burning.....	9
5.7 Safety measures against bursting.....	9
5.8 Sharpening device.....	9
5.9 Workplaces, access stairs, catwalks, passageways.....	9
5.10 Start-up warning device.....	10
5.11 Emergency stop device.....	10
5.12 Isolation and energy dissipation, prevention of unexpected start-up.....	10
5.13 Equipment and measures for make-ready and repair.....	10
5.14 Safety measures for cleaning and trouble shooting.....	10
5.15 Control systems and actuators.....	11
5.16 Noise.....	11
5.17 Integrated lighting.....	11
5.18 Ergonomic principles.....	11
5.19 Electrical equipment.....	11
5.20 Hydraulic equipment.....	11
5.21 High-pressure cleaning devices.....	11
6 Verification of safety requirements and/or measures.....	12
7 Information of use.....	12
Annex ZA (informative) Relationship between this European Standard and the Essential Requirements of EU Directive 98/37/EC.....	13
Bibliography.....	14

## Foreword

This European Standard (EN 1034-22:2005) has been prepared by Technical Committee CEN/TC 198 "Printing and paper machines - Safety", the secretariat of which is held by DIN.

This European Standard shall be given the status of a national standard, either by publication of an identical text or by endorsement, at the latest by December 3005, and conflicting national standards shall be withdrawn at the latest by December 2005.

This European Standard has been prepared under a mandate given to CEN by the European Commission and the European Free Trade Association, and supports essential requirements of **EU Directive(s)**.

For relationship with EU Directive(s), see informative Annex ZA, which is an integral part of this document.

According to the CEN/CENELEC Internal Regulations, the national standards organizations of the following countries are bound to implement this European Standard: Austria, Belgium, Cyprus, Czech Republic, Denmark, Estonia, Finland, France, Germany, Greece, Hungary, Iceland, Ireland, Italy, Latvia, Lithuania, Luxembourg, Malta, Netherlands, Norway, Poland, Portugal, Slovakia, Slovenia, Spain, Sweden, Switzerland and the United Kingdom.

## iTeh STANDARD PREVIEW (standards.iteh.ai)

SIST EN 1034-22:2005

<https://standards.iteh.ai/catalog/standards/sist/8ae39b8f-6bee-4926-a47f-1cc088c22f72/sist-en-1034-22-2005>

## Introduction

This European Standard is a C type standard as stated in EN ISO 12100-1.

The machinery concerned and the extent to which hazards, hazardous situations and events are covered are indicated in the scope of this European Standard.

For machines that have been designed and built according to the provisions of this C standard, the following stipulation applies: When provisions of this type C standard are different from those which are stated in type A or B standards or from provisions made in EN 1034-1:2000, the provisions of this type C standard take precedence over the provisions of the other standards.

## 1 Scope

This European Standard applies to wood grinders intended for the production of pulp used in paper making including sharpening devices and shall be used together with EN 1034-1:2000. It deals with all significant hazards, hazardous situations and hazard events relevant to wood grinders when used as intended and under the conditions foreseen by the manufacturer (see clause 4). This standard does not apply to loading facilities. Hazards caused by overpressure are not covered by this standard.

Note: For hazards caused by overpressure, see the directive for pressure vessels.

This European Standard is not applicable to wood grinders manufactured before the date of publication of this European Standard by CEN.

iTech STANDARD PREVIEW  
(standards.iteh.ai)  
SIST EN 1034-22:2005  
<https://standards.iteh.ai/catalog/standards/sist/8ae39b8f-6bee-4926-a47f-1cc088c22f72/sist-en-1034-22-2005>

## 2 Normative references

The following referenced documents are indispensable for the application of this European Standard. For dated references, only the edition cited applies. For undated references, the latest edition of the referenced document (including any amendments) applies.

EN 294:1992, *Safety of machinery — Safety distances to prevent danger zones being reached by the upper limbs*

EN 418:1992, *Safety of machinery — Emergency stop equipment — Functional aspects*

EN 563:1994, *Safety of machinery — Temperatures of touchable surfaces — Ergonomics data to establish temperature limit values for hot surfaces*

EN 547-2:1996, *Safety of machinery — Human body measurements — Part 2: Principles for determining the dimensions required for access openings*

EN 953:1997, *Safety of machinery — Guards — General requirements for the design and construction of fixed and movable guards*

EN 954-1:1996, *Safety of machinery — Safety-related parts of control systems — Part 1: General principles for design*

EN 982:1996, *Safety requirements for fluid power systems and their components — Hydraulics*

EN 1034-1:2000, *Safety of machinery — Safety requirements for the design and construction of paper making and finishing machines — Part 1: Common requirements*

EN 1050:1996, *Safety of machinery — Principles for risk assessment*

EN 1837:1995, *Safety of machinery — Integral lighting of machines*

EN 13023:2003, *Noise measurement methods for printing, paper converting, paper making machines and auxiliary equipment — Accuracy categories 2 and 3*

EN 60204-1:1997, *Safety of machinery — Electrical equipment of machines — Part 1: General requirements (IEC 60204-1:1997)*

EN 60204-11:2000, *Safety of machinery — Electrical equipment of machines — Part 11: High voltage equipment for voltages above 1000 V AC or 1500 V DC up to 36 kV (IEC 60204-11:2000)*

EN 60529:1992, *Degrees of protection provided by enclosures (IP code) (IEC 60529:1989)*.

EN 61000-6-2:2001, *Electromagnetic compatibility (EMC) — Part 6-2: Generic standards; immunity for industrial environment (IEC 61000-6-2:1999, modified)*

EN ISO 11957:1996, *Acoustics — Determination of sound insulation performance of cabins — Laboratory and in situ measurements (ISO 11957:1996)*

EN ISO 12100-1:2003, *Safety of machinery — Basic concepts, general principles for design — Part 1: Basic terminology, methodology (ISO 12100-1:2003)*.

EN ISO 12100-2:2003, *Safety of machinery — Basic concepts, general principles for design — Part 2: Technical principles (ISO 12100-2:2003)*.

EN ISO 14122:2001 (all parts), *Safety of machinery — Permanent means of access to machines and industrial plants*

SIST EN 1034-22:2005  
<https://standards.iech.at/catalog/standards/sist/8ac3968f-0bce-4926-a47f-1cc088c22f72/sist-en-1034-22-2005>

### 3 Terms and definitions

For the purposes of this European Standard, the definitions given in EN 1034-1:2000, EN ISO 12100-1:2003 and the following definitions apply:

#### 3.1

##### **wood pulp**

suspension of wood-base fibre in water

#### 3.2

##### **wood grinder**

machine for the production of wood pulp with a grinding body (grinding stone) driven by motor or hydraulic power against which debarked logs are pressed. Wood fibre is ground off with the addition of water and discharged as wood pulp

#### 3.3

##### **hydraulic press grinder**

wood grinder equipped with hydraulic press shoes to press the wood stored in several chambers against the grinding body. A hydraulic press grinder with two chambers is illustrated in Figure 1

#### 3.4

##### **pressure grinder**

hydraulic press grinder where the grinding chamber is enclosed for grinding under vapour pressure

### 3.5 continuous grinder

wood grinder with continuous feeding of wood, for example by means of chains or by gravity. A continuous grinder is illustrated in Figure 2

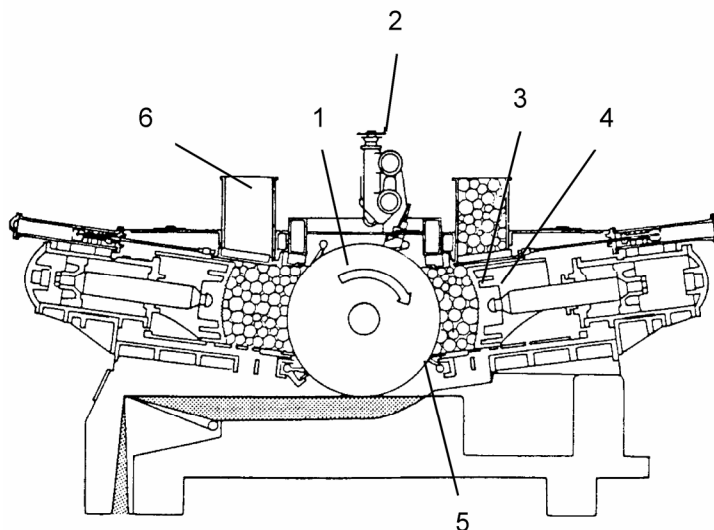

#### Key

- 1 Grinding stone
- 2 Sharpening device
- 3 Press shoe

iTeh STANDARD PREVIEW  
(standards.iteh.ai)

NOTE: Safety devices are not shown.

SIST EN 1034-22:2005  
<https://standards.iteh.ai/catalog/standards/sist/8ae39b8f-6bee-4926-a47f-1cc088c22f72/sist-en-1034-22-2005>

**Figure 1 — Hydraulic pressure grinder (example)**

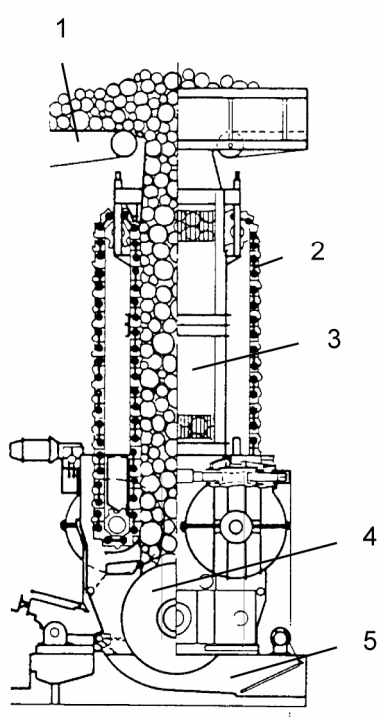

**Key**

- 1 Continuous feeder
- 2 Feeding chain
- 3 Feeding hopper

- 4 Grinding stone
- 5 Trough

**iTeh STANDARD PREVIEW**  
(standards.iteh.ai)

NOTE: Safety devices are not shown.

SIST EN 1034-22:2005  
<https://standards.iteh.ai/catalog/standards/sist/8ae39b8f-6bee-4926-a47f-1cc088c22f72/sist-en-1034-22-2005>

**Figure 2 — Continuous wood grinder (example)**

#### 4 List of significant hazards

Table 1 of this clause contains all the significant hazards, as far as they are dealt with in this European Standard, which are identified by risk assessment in accordance with EN 1050 as significant for this type of machinery and which require action to eliminate or reduce the risk. When carrying out the risk assessment the machine designer will have to check whether the list of hazards in Table 1 is complete and applicable with respect to the particular machine.