

INTERNATIONAL
STANDARD

ISO
3739-3

First edition
1995-12-15

Industrial tyres and rims —

Part 3:

Rims

iTeh STANDARD PREVIEW

(standards.iteh.ai)

Pneumatiques et jantes pour matériel de manutention —

Partie 3: Jantes

[ISO 3739-3:1995](#)

<https://standards.iteh.ai/catalog/standards/sist/a0e16ffe-ed57-468b-8d26-fa2baf198e1b/iso-3739-3-1995>



Reference number
ISO 3739-3:1995(E)

Foreword

ISO (the International Organization for Standardization) is a worldwide federation of national standards bodies (ISO member bodies). The work of preparing International Standards is normally carried out through ISO technical committees. Each member body interested in a subject for which a technical committee has been established has the right to be represented on that committee. International organizations, governmental and non-governmental, in liaison with ISO, also take part in the work. ISO collaborates closely with the International Electrotechnical Commission (IEC) on all matters of electrotechnical standardization.

Draft International Standards adopted by the technical committees are circulated to the member bodies for voting. Publication as an International Standard requires approval by at least 75 % of the member bodies casting a vote.

International Standard ISO 3739-3 was prepared by Technical Committee ISO/TC 31, *Tyres, rims and valves*, Subcommittee SC 7, *Industrial tyres and rims*.

ISO 3739 consists of the following parts, under the general title *Industrial tyres and rims*:

- Part 1: *Pneumatic tyres (metric series) on 5 degrees tapered or flat base rims — Designation, dimensions and marking*
- Part 2: *Pneumatic tyres (metric series) on 5 degrees tapered or flat base rims — Load ratings*
- Part 3: *Rims*

Annex A forms an integral part of this part of ISO 3739.

© ISO 1995

All rights reserved. Unless otherwise specified, no part of this publication may be reproduced or utilized in any form or by any means, electronic or mechanical, including photocopying and microfilm, without permission in writing from the publisher.

International Organization for Standardization
Case Postale 56 • CH-1211 Genève 20 • Switzerland

Printed in Switzerland

Industrial tyres and rims —

Part 3: Rims

1 Scope

This part of ISO 3739 specifies the main requirements, including size designation and marking, of 5° tapered and flat base rims with diameters not exceeding rim diameter code 15 for pneumatic tyres, and for solid tyres for pneumatic tyre rims, primarily intended for industrial vehicles for use on prepared surfaces.

ISO 3739-1 gives the designation, dimensions and marking, and ISO 3739-2 the load ratings of pneumatic tyres (metric series). ISO 10499 covers the designation, dimensions and marking of rubber solid tyres (metric series) for pneumatic tyre rims.

Rim dimensions are specified for size and contour only. The tyre and the wheel/rim manufacturers have to be consulted for confirmation of the suitability of the tyre/rim combinations, particularly with regard to rim profile and wheel strength.

2 Normative reference

The following standard contains provisions which, through reference in this text, constitute provisions of this part of ISO 3739. At the time of publication, the edition indicated was valid. All standards are subject to revision, and parties to agreements based on this part of ISO 3739 are encouraged to investigate the possibility of applying the most recent edition of the standard indicated below. Members of IEC and ISO maintain registers of currently valid International Standards.

ISO 3911:1977, *Wheels/rims — Nomenclature, designation, marking, and units of measurement*.

3 Definitions

For the purposes of this part of ISO 3739, the definitions given in ISO 3911 apply.

4 Designation and marking

Rim designation and marking shall be in accordance with ISO 3911:1977, clauses 3 and 4 respectively.

5 Rim profiles

5.1 Existing rims

Profiles of existing rims shall be as given in annex A.

The flange widths include edge radius. The portion of the flange beyond the minimum width shall be lower than the highest point of the flange.

5.2 Additional rims

As far as possible, existing rims (see 5.1) should be used for the metric series of tyres; only if absolutely necessary should new profiles be considered.

If additional rims are designed, the requirements in 5.2.1 and the recommendation in 5.2.2 apply.

5.2.1 Requirements

The new rim width code shall be chosen from the following range:

2.50; 3.25; 4.00; 5.00; 6.50; 8.00; 10.00

Any rim profile shall be independent from the rim diameter, i.e. no change of profile is related to the diameter.

The rim shall have a 5° tapered bead seat.

The specified rim diameter shall be as given in table 1.

5.2.2 Recommendation

The flange height should be in the range 13 % to 20 % of the tyre section height.

Table 1 — Specified rim diameter

Nominal rim diameter code	Specified rim diameter <i>D</i> ¹⁾ ± 0,4 mm
4	100,8
6	151,6
8	202,4
9	227,8
10	253,2
12	308,8
15	387,4

1) Tolerance is for tyre design purpose only. The rim measurement is made by a circumference-measuring tape related to a mandrel.

ISO 3739-3:1995

<https://standards.iteh.ai/catalog/standards/sist/a0e16ffe-ed57-468b-8d26-fa2bafd98e1b/iso-3739-3-1995>

Annex A (normative)

Existing rims

This annex gives detailed characteristics of existing rim profiles for which an index is given in table A.1.

Tables A.3, A.5, A.7 and A.9 give existing combinations of dimension and nominal rim diameter code, as indicated by a cross (×). The specified rim diameter, D , may be found in table 1.

Table A.1 — Index of existing rims

Rim width code	Existing rims	Rim profile details are indicated in	
		figures	tables
2.50	4 — 2.50 C 8 — 2.50 C	A.1 and A.2 A.1 and A.2	A.2, A.3, A.4 and A.5 A.2, A.3, A.4 and A.5
3.25	4 — 3.25 I 6 — 3.25 I 8 — 3.25 I	A.1 A.1 A.1	A.2 and A.3 A.2 and A.3 A.2 and A.3
4.0	9 — 4.00 E	A.1, A.2 and A.3	A.2, A.3, A.4, A.5, A.6 and A.7
5.0	10 — 5.00 F 12 — 5.00 S 15 — 5.00 1)	A.1 and A.3 A.1 and A.3 A.4	A.2, A.3, A.6 and A.7 A.2, A.3, A.6 and A.7 A.8 and A.9
6.5	10 — 6.50 F 15 — B 6.5 15 — 6.5 1)	A.1 and A.3 A.4 A.4	A.2, A.3, A.6 and A.7 A.8 and A.9 A.8 and A.9
8.0	12 — 8.00 G 15 — 8.0 15 — B 8.0	A.3 A.4 A.4	A.6 and A.7 A.8 and A.9 A.8 and A.9
1) Rims with identical designation but different dimensions exist.			

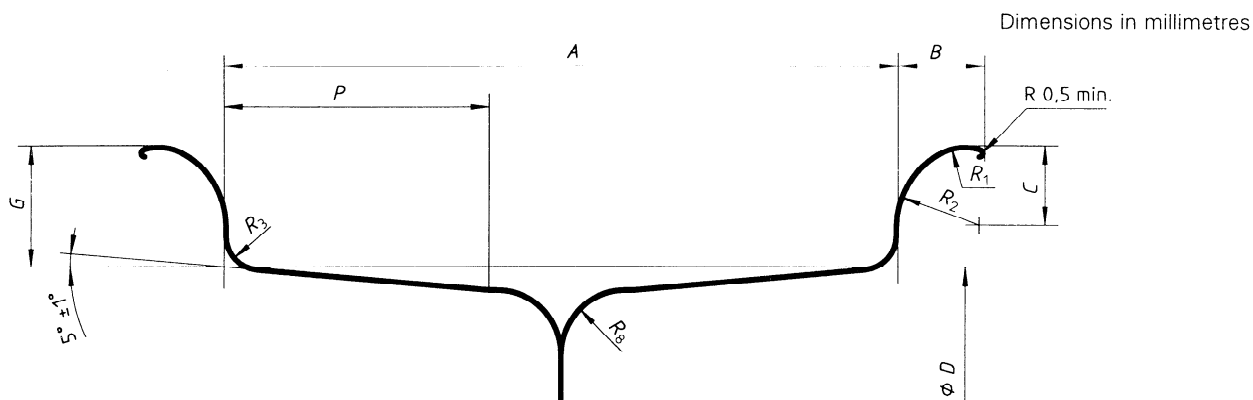

Figure A.1 — Tapered divided rims

Table A.2 — Tapered divided rims — Rim contours

Dimensions in millimetres

Rim width code	A ± 2	G ± 1	B min.	C	P min.	R ₁	R ₂	R ₃ max.	R ₈ max.
2.50 C	63,5	16,5 ± 1	11	11,5	12	7,5	12	3,5	5
3.25 I	82,5	16 ± 1	10	—	—	—	9	4,5	8
4.00 E	101,5	20 ± 1	12,5	13,5	25	8,5	14	6,5	10
5.00 S	127	31,5 ± 1,5	19	19,5	43	18,5	18,5	8	16
5.00 F	127	22,5 ± 1	13	14,5	23,5	9,5	15,5	6,5	12
6.50 F	165	22,5 ± 1	13	14,5	—	9,5	15,5	6,5	12

Table A.3 — Tapered divided rims — Size range of existing rims

Rim width code	Nominal rim diameter code					
	4	6	8	9	10	12
2.50 C	x		x			
3.25 I	x	x	x			
4.00 E				x		
5.00 S						x
5.00 F					x	
6.50 F					x	

Dimensions in millimetres

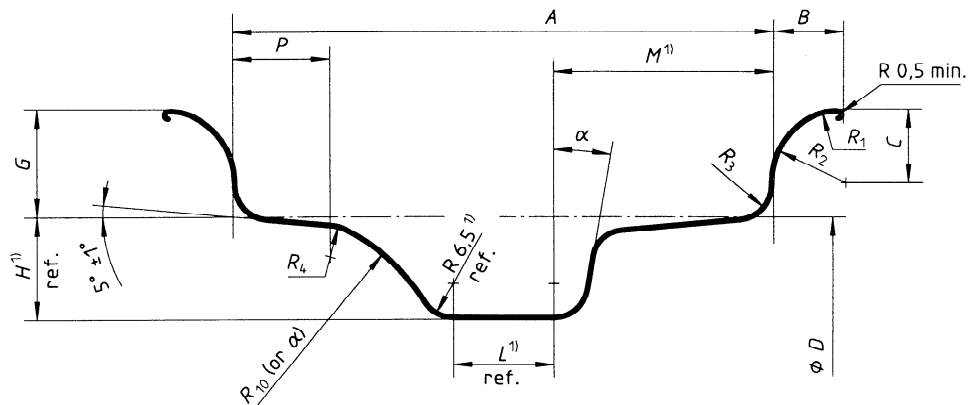

1) These dimensions comprise the minimum well envelope for tyre-mounting purposes.

Figure A.2 — 5° drop-centre rims

Table A.4 — 5° drop centre rims — Rim contours

Dimensions in millimetres

Rim width code	A	G	B	C	P	H	L	M	R ₁	R ₂	R ₃	R ₄	R ₁₀	α
	± 2	± 1	min.		min.	ref.	ref.	max.			max.	min.		min.
2.50 C	63,5	16,5	11	11,5	12	13,5	12,5	25,5	7,5	12	3,5	6	28,5	13°
4.00 E	101,5	20	12,5	13,5	18	19	19	35	8,5	14	6,5	6	38	10°

Table A.5 — 5° drop-centre rims — Size range of existing rims

Rim width code	Nominal rim diameter code		
	4	8	9
2.50 C	×	×	
4.00 E			×

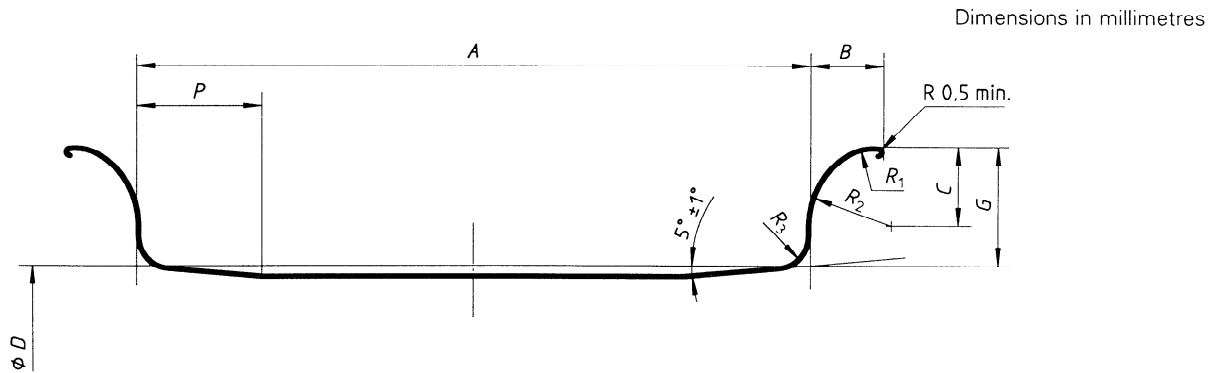

NOTE — Flange and bead seat shall be removable on one side of the rim.

Figure A.3 — 5° tapered rim for codes 4.00 E; 5.00 S; 5.00 F; 6.50 F and 8.00 G

Table A.6 — 5° tapered rims for codes 4.00 E; 5.00 S; 5.00 F; 6.50 F and 8.00 G — Rim contours

Dimensions in millimetres

Rim width code	A	G	B min.	P min.	C	R ₁	R ₂	R ₃ max.
4.00 E	101,5 ± 2	20 ± 1	12,5	25	13,5	8,5	14	6,5
5.00 S	127 ± 2,5	31,5 ± 1,5	19	43	—	—	18,5	8
5.00 F	127 ± 2	22,5 ± 1	13	23,5	14,5	9,5	15,5	6,5
6.50 F	165 ± 2	22,5 ± 1	13	34	14,5	9,5	15,5	6,5
8.00 G	203 ± 3	28 ± 1	14,5	40,5	—	—	14	7,5

Table A.7 — 5° tapered rims for codes 4.00 E; 5.00 S; 5.00 F; 6.50 F and 8.00 G — Size range of existing rims

Rim width code	Nominal rim diameter code		
	9	10	12
4.00 E	x		
5.00 S			x
5.00 F		x	
6.50 F		x	
8.00 G			1)

1) This combination exists, with a specified rim diameter, *D*, of 304 mm ± 0,4 mm but is not for new rim designs.

Dimensions in millimetres

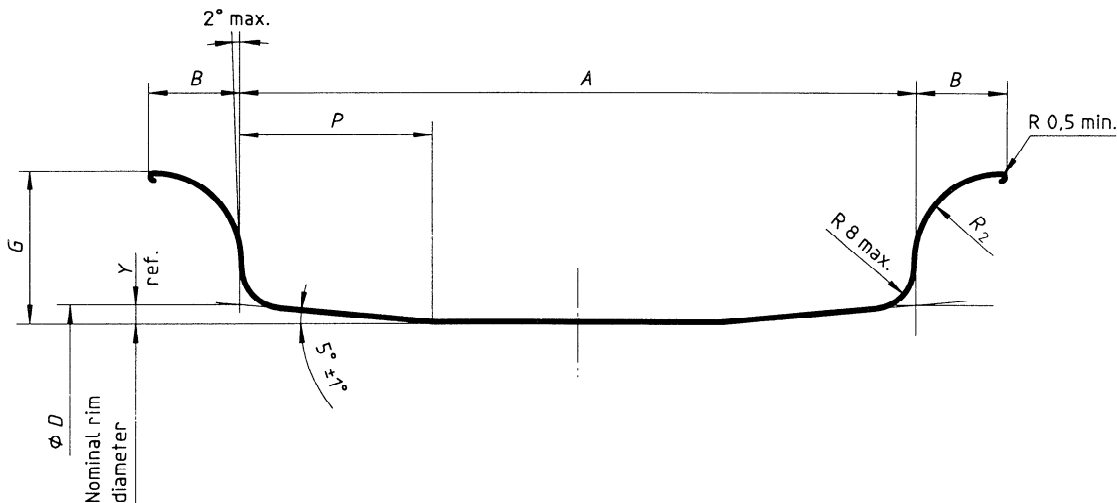

NOTE — Flange and bead seat shall be removable on one side of the rim.

Figure A.4 — 5° tapered rims for codes 5.0; 6.5; B 6.5; 8.0 and B 8.0

Table A.8 — 5° tapered rims for codes 5.0; 6.5; B 6.5; 8.0 and B 8.0 — Rim contours

Dimensions in millimetres

Rim width code	A ± 3,5	G ± 1,5	B min.	R ₂ ± 2,5	Y ¹⁾ ref.	P min.
5.0 ²⁾	127	28	16,5	14	3	36
6.5 ²⁾	165	35,5	20	18	3	36
B 6.5	165	38	21,5	19	2,5	27
8.0	203	43	24	21,5	3	36
B 8.0	203	43	24	21,5	2,5	27

1) Y = Distance of specified rim diameter profile from nominal diameter profile.

2) Rims with the same designation but different dimensions exist.

Table A.9 — 5° tapered rims for codes 5.0; 6.5; B 6.5; 8.0 and B 8.0 — Size range of existing rims

Rim width code	Nominal rim diameter code 15
5.0	×
6.5	×
B 6.5	1)
8.0	×
B 8.0	1)

1) This combination exists, with a specified rim diameter, D, of 385,8 mm ± 0,4 mm but is not for new rim designs.