



Designation: **D4547–09 D4547 – 15**

Standard Guide for Sampling Waste and Soils for Volatile Organic Compounds¹

This standard is issued under the fixed designation D4547; the number immediately following the designation indicates the year of original adoption or, in the case of revision, the year of last revision. A number in parentheses indicates the year of last reapproval. A superscript epsilon (ϵ) indicates an editorial change since the last revision or reapproval.

1. Scope

1.1 This guide describes recommended procedures for the collection, handling, and preparation of solid waste, soil, and sediment samples for subsequent determination of volatile organic compounds (VOCs). This class of compounds includes low molecular weight aromatics, hydrocarbons, halogenated hydrocarbons, ketones, acetates, nitriles, acrylates, ethers, and sulfides with boiling points below 200° Celsius (C) that are insoluble or slightly soluble in water.

1.2 Methods of sample collection, handling, storage, and preparation for analysis are described.

1.3 This guide does not cover the details of sampling design, laboratory preparation of containers, and the analysis of the samples.

1.4 It is recommended that this guide be used in conjunction with Guide **D4687**.

1.5 The values stated in SI units are to be regarded as standard. No other units of measurement are included in this standard.

1.6 *This standard does not purport to address all of the safety concerns, if any, associated with its use. It is the responsibility of the user of this standard to establish appropriate safety and health practices and determine the applicability of regulatory limitations prior to use.*

2. Referenced Documents

2.1 *ASTM Standards:*²

[D1193 Specification for Reagent Water](#)

[D1586 Test Method for Penetration Test \(SPT\) and Split-Barrel Sampling of Soils](#)

[D3550 Practice for Thick Wall, Ring-Lined, Split Barrel, Drive Sampling of Soils](#)

[D4687 Guide for General Planning of Waste Sampling](#)

[D4700 Guide for Soil Sampling from the Vadose Zone](#)

[D5058 Practices for Compatibility of Screening Analysis of Waste](#)

[D5681 Terminology for Waste and Waste Management](#)

[D5792 Practice for Generation of Environmental Data Related to Waste Management Activities: Development of Data Quality Objectives](#)

[D6051 Guide for Composite Sampling and Field Subsampling for Environmental Waste Management Activities](#)

[D6282 Guide for Direct Push Soil Sampling for Environmental Site Characterizations](#)

[D6418 Practice for Using the Disposable En Core Sampler for Sampling and Storing Soil for Volatile Organic Analysis](#)

[D6640 Practice for Collection and Handling of Soils Obtained in Core Barrel Samplers for Environmental Investigations](#)

~~[E856 Definitions of Terms and Abbreviations Relating to Physical and Chemical Characteristics of Refuse Derived Fuel](#)~~
(Withdrawn 2011)³

2.2 *Federal Standard:*

[Title 49 Transportation, Code of Federal Regulations \(CFR\), Part 172, List of Hazardous Substances and Reportable Quantities](#)³

3. Terminology

3.1 *sample, n*—a portion of material taken from a larger quantity for the purpose of estimating properties or composition of the larger quantity. (**E856D5681**)

¹ This guide is under the jurisdiction of ASTM Committee **D34** on Waste Management and is the direct responsibility of Subcommittee **D34.01.02** on Sampling Techniques. Current edition approved July 1, 2009; Sept. 1, 2015. Published August 2009; October 2015. Originally approved in 1991. Last previous edition approved in 2006 as **D4547–06**; **D4547–09**. DOI: 10.1520/D4547-09.10.1520/D4547-15.

² For referenced ASTM standards, visit the ASTM website, www.astm.org, or contact ASTM Customer Service at service@astm.org. For *Annual Book of ASTM Standards* volume information, refer to the standard's Document Summary page on the ASTM website.

³ Available from Superintendent of Documents, U.S. Government Printing Office, Washington, DC 20402.

3.2 *subsample, n*—a portion of a sample taken for the purpose of estimating properties or composition of the whole sample. **(D6051)**

3.2.1 *Discussion*—

A subsample, by definition, is also a sample.

4. Summary of Guide

4.1 This guide addresses the use of tools for sample collection and transfer, conditions for sample storage, sample preservation, and two common means of sample preparation for analysis. Special attention is given to each step from sample collection to analysis to limit the loss of VOCs by volatilization and biodegradation. The sample collected and analyzed should be representative of the matrix material sampled. The two methods cited for the preparation of samples for VOC analysis are methanol extraction and vapor partitioning (that is, ~~purge-and-trap-and-headspace~~; purge-and-trap, headspace, and vacuum distillation). The method of sample preparation for VOC analysis should be consistent with the data quality objectives (see Practice **D5792**).

5. Significance and Use

5.1 This guide describes sample collection and handling procedures designed to minimize losses of VOCs. The principal mechanisms for the loss of VOCs from materials during collection, handling and storage are volatilization and biodegradation. Susceptibility of various VOCs to these two loss mechanisms is both compound and matrix specific. In general, compounds with higher vapor pressures are more susceptible to volatilization than compounds with lower vapor pressures. Also, aerobically degradable compounds are generally more susceptible to biodegradation than anaerobically degradable compounds. In some cases, the formation of other compounds not originally present in the material can occur. Loss or gain of VOCs leads to analytical results that are unrepresentative of field conditions.

5.2 Ancillary information concerning sample collection, handling and storage for VOC analysis is provided in **Appendices Appendix X1, Appendix X2, and Appendix X3**. These appendices and cited references are recommended reading for those unfamiliar with the many challenges presented during the collection, handling and storage of samples for VOC analysis.

6. Selection of Sample Preparation Method for VOC Analysis

6.1 Introduction:

6.1.1 Sample collection, handling, and preservation methods should be compatible with the method used to prepare the sample for VOC analysis, and meet the project's data quality objectives (see Practice **D5792**). Preparation of a sample for instrumental analysis can be initiated either in the field or laboratory. In either case, prior to analysis, the sample should be placed into a tared volatile organic analysis (VOA) vial or bottle meeting the specifications given in **7.3**. When working with an uncharacterized solid waste, it is advisable to perform compatibility tests (see Test Methods **D5058**) between the sample material and the solution (see **6.2** and **6.3**) into which it will be transferred in preparation for analysis. For instance, when collecting highly contaminated soils or waste of unknown composition, it is strongly recommended that preliminary testing be performed to adequately characterize the waste materials so that when the user applies the procedures cited in this guide, there will be no chemical reaction which may jeopardize the user's safety.

6.1.2 **Figs. 1 and 2** are flow diagrams showing some different options for combining sample collection, handling and preparation methods for instrumental analysis.

6.2 Methanol Extraction:

6.2.1 This method involves the extraction of VOCs from a sample with methanol and the subsequent transfer of an aliquot of the extract to water for either ~~purge-and-trap or headspace analysis~~; purge-and-trap, headspace analysis, or vacuum distillation.

6.2.2 Advantages of methanol extraction are (1) large samples or composite samples, or both, can be collected to enhance representativeness (see Guide **D6051**), (2) biodegradation is inhibited, (3) an efficient extraction of VOCs from the matrix materials can be achieved with methanol due to its strong affinity for these compounds and favorable wetting properties, (4) a subsample can be analyzed several times, and (5) sample extracts can be archived, if verified that VOC losses have not occurred (see **10.1.1**)).

6.2.3 The primary disadvantages of methanol extraction are (1) samples may have to be shipped as a flammable liquid depending on the amount of methanol present (for example, U.S. DOT reg. 49CFR§172.101), (2) hazards to personnel due to methanol's toxicity and flammability, (3) detection limits are elevated due to analyte dilution, (4) possible interference of the methanol peak with VOCs of interest, (5) potential adverse impact of methanol on the performance of certain gas chromatograph/detector systems, and (6) samples extracted with methanol must be disposed of as a regulated waste.

6.2.4 Logistical challenges of performing these tasks in the field can be overcome by extracting samples with methanol once they have been received in a laboratory, provided that the samples are transported in an airtight container (see **7.3.2, 9.1** and **9.2**). Furthermore, if VOC levels are unknown, a replicate sample can be obtained and screened to determine if methanol extraction is appropriate for the expected contaminant concentrations.

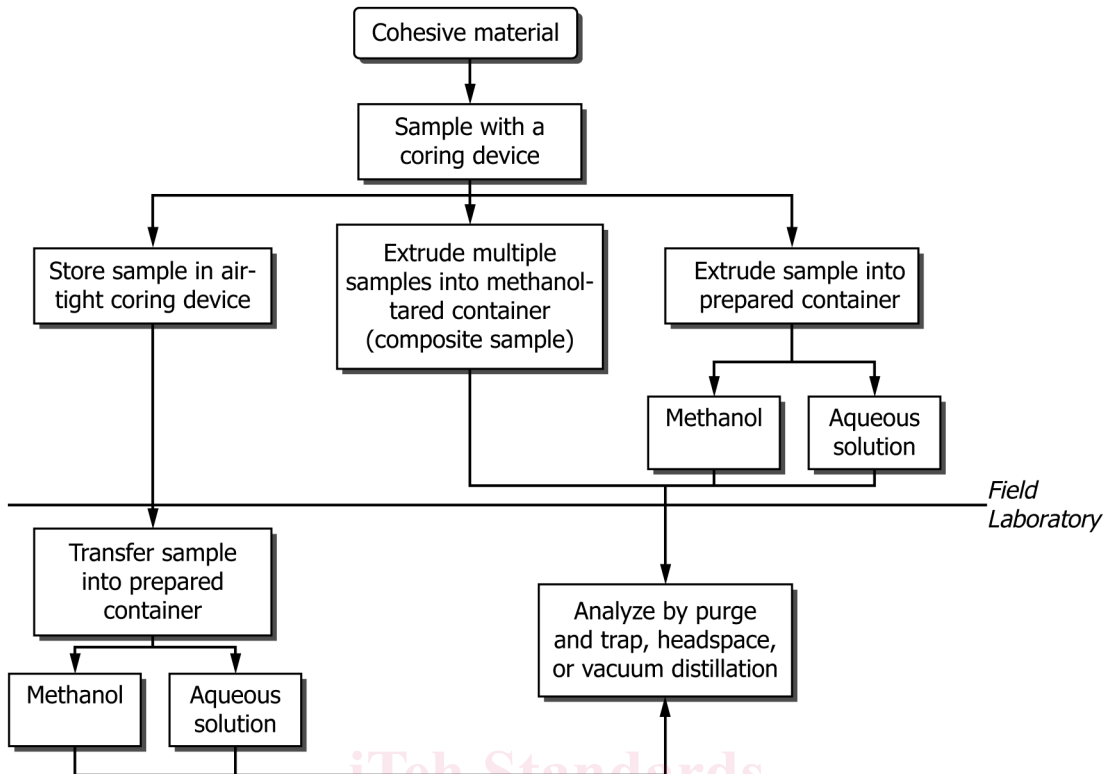

FIG. 1 Sample Handling Options for Cohesive Materials

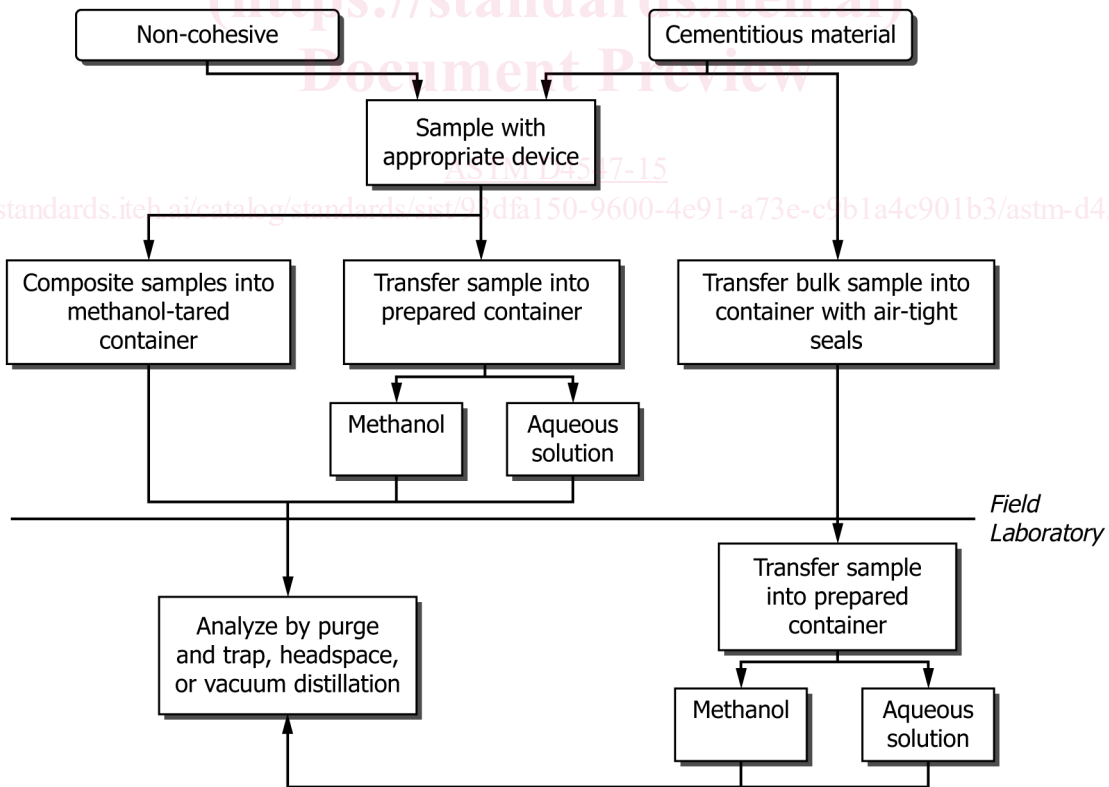

FIG. 2 Sample Handling Options for Non-Cohesive and Cementitious Materials

6.3 Vapor Partitioning:

6.3.1 Vapor partitioning involves the direct analysis of a sample by either ~~purge-and-trap or headspace~~. In both cases, purge-and-trap, headspace, or vacuum distillation. In each case, the sample is placed into a tared volatile analysis (VOA) vial or flask (for vacuum distillation) containing water or a preservative solution (for example, acidified water) from which the vapor is removed for analysis without the container being opened.

6.3.2 The principal advantages of this method are (1) it can offer lower detection limits than methanol extraction because no dilution is involved, (2) there are no organic solvent interferences, and (3) there is no use of regulated organic solvents, which may require special shipment, disposal, and field handling practices.

6.3.3 The disadvantages associated with vapor partitioning are (1) the VOA vial (VOA vials are different sizes for automated purge-and-trap and headspace instrumentation) or adapter used in conjunction with a VOA vial, or both, often are instrument specific, (2) sample size is limited (<10 g) by automated systems, (3) a matrix-appropriate method of preservation may be necessary (see [Appendix X2](#)), (4) vapor partitioning is less efficient at recovering VOCs from some materials than methanol extraction, and (5) when using ~~purge-and-trap, purge-and-trap or vacuum distillation~~, only a single analysis of the same sample can be made; similarly only a single analysis may be possible with headspace analysis unless concentrations allow for the use of a small injection volume.

6.3.4 Limitations imposed by vapor phase partitioning methods with regard to number of analyses that can be performed on a single sample can be addressed by taking replicate samples.

6.3.5 When employing vapor phase partitioning methods, the logistical challenges of performing sample preparation in the field (see [7.3.3](#)) can be avoided by performing the preparation step in the laboratory, so long as the sample is transported to the laboratory in an airtight container (see [7.2.1](#)). If VOC levels are unknown, a replicate sample can be obtained and screened to determine if it is appropriate to use a vapor partitioning method of sample preparation.

7. Sampling Tools and Containers

7.1 All sample handling devices and vessels used to collect and store samples for analysis should be constructed of nonreactive materials that will not sorb, leach or diffuse constituents of interest. Examples of materials that meet these criteria are glass, stainless steel, steel, and brass. Materials, such as ~~polytetrafluoroethylene~~ polytetrafluoroethylene (PTFE) and many rigid plastics also can be ~~used~~; however, it should be recognized that they may have some limited adsorptive properties or allow slow diffusive passage of some VOCs. Materials which show limited reactivity can be used when they have a very short period of contact with the sample or when they are necessary for making airtight (hermetic) seals. Collection tools and storage containers made of materials other than those cited in this section should only be used after they have demonstrated equivalency (see [7.2.1](#)). All collection tools and storage containers should be cleaned in a manner consistent with their intended use.

7.2 *Tools*—There are often several steps to sampling, particularly if it involves obtaining bulk material from the subsurface. Most of the equipment used to obtain samples from the subsurface was originally developed for the geotechnical industry; however, several devices have been developed specifically for environmental sampling by direct push methods (Guide [D6282](#)). The subsurface bulk sampling systems are designed to obtain intact cylindrical cores of material, ranging anywhere from 2.5 to 10.2 cm in diameter and 30.5 cm or more in length. Two geotechnical tools that have been used for subsurface sample collection are the split-spoon sampler (Test Method [D1586](#)), which opens to expose the entire length of the material obtained for subsampling, and core barrel liners (ring-lined barrel sampling, see Practice [D3550](#)) that are typically subsampled through open ends. Core barrel liners should not be used for storage of samples intended for VOC analysis because they do not have airtight seals, see [Appendix X1](#). Single tube and dual tube sampling devices have been developed for environmental applications (Guide [D6282](#)) and are usually operated by direct push methods. Sample liners used in the bulk sampling systems come in a variety of lengths and materials (stainless steel, brass, PTFE, rigid plastics, etc.). Additional information on the design and application of different types of subsurface collection systems that are available can be found in Guide [D4700](#) and Guide [D6282](#). Subsurface materials retrieved for VOC characterization should be obtained (sampling tubes filled and brought to the surface) as quickly as possible and remain intact and undisturbed until they are subsampled (see Practice [D6640](#)). Subsampling a bulk sample should occur as quickly as possible after it is brought to the surface. It is important for subsampling to occur quickly because for bulk sample retrieval systems where the material is exposed directly to the atmosphere for a period of time during subsampling, there is an opportunity for VOC loss to occur. Suggested liner configurations and examples of sampling techniques for bulk soil samples collected by single tube direct push methods that provide limited exposure of the soil being sampled to the atmosphere, are described in [Appendix X3](#) (see [8.1](#) through [8.3](#) for additional sampling guidance).

7.2.1 In addition to the coring devices which retrieve bulk quantities of material, there are smaller hand-operated coring tools for obtaining samples of the appropriate size (for example, coring devices capable of collecting 3- and 15-cm³ volumes, for collection of approximately 5- and 25-g samples, respectively) for analysis (see [Fig. 3](#)). If one of these smaller coring devices is used to store the sample (see [9.1.1](#)), the main body ~~should~~ shall be constructed of materials that are nonreactive and have airtight seals that show limited sorption and penetration of VOCs. Hand-operated coring devices that are used to store samples ~~should~~ shall be evaluated using the procedure given in [Appendix X4](#) to ensure that the device meets these criteria. Any alternate evaluation technique shall produce equal or better recoveries of the compounds stated in [Appendix X4](#). When the coring device is only used to rapidly transfer the sample to a VOA vial, corer material requirements are less stringent.

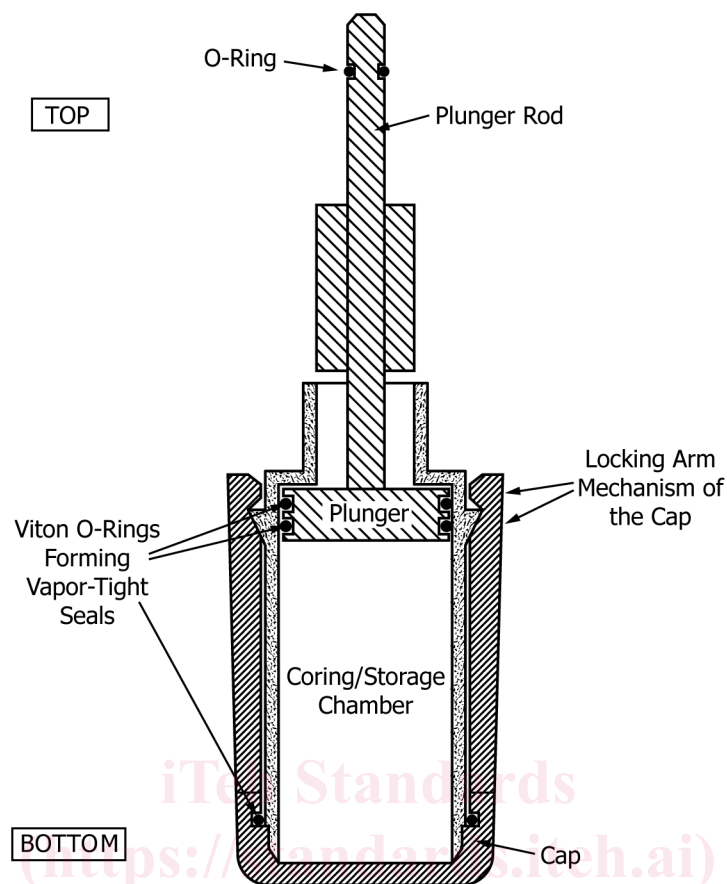

FIG. 3 Components of the En-Miniature Core Sampler

7.3 Containers—VOA vials and bottles used for storage and preparation of samples for analysis should be made of glass and have airtight seals. To achieve an airtight seal, these containers should have a thick septum cushion between the sealing material (PTFE) and cap (rigid plastic screw cap or aluminum crimp top). PTFE-lined caps that do not have flexible septum backing often fail to achieve a liquid or airtight seal. Furthermore, the thickness of the PTFE used for a lined septum should be at least 0.254 mm.

7.3.1 Preparation of VOA Vial or Bottle—Record the tared weight of the VOA vial or bottle and cap prior to the sampling event. Moreover, depending on the method of sample preparation and analysis, the vessel may also contain a solvent, or VOC free water, and if required a PTFE or glass coated stir bar at the time of sample collection (see Section 9).

7.3.2 Preparation of Containers for Methanol Extraction—Container preparation applies to both field and laboratory sample preparation. The appropriate volume of analytical-grade methanol (high performance liquid chromatography, spectrographic or purge and trap) is added to the organic-free container by the laboratory that supplies the container, by the sample collector, or by a third party. The party that adds the methanol to the container should also be responsible for providing trip blanks (see Guide D4687). If methanol is present in the sample container in the field, this container should be opened only to add the sample(s). The tared weight of the container with methanol should be recorded prior to adding the sample to the container. A predetermined volume of sample that corresponds to a weight in grams (g) that is equivalent to or less than the volume (mL) of methanol can then be introduced. The ratio (typically 1:1 to 10:1, methanol to material) between the two constituents should allow for formation of a clear layer of methanol over the sample after thorough mixing. The difference in weight of the container and cap, measured before and after the sample is introduced, is used to establish the sample's wet weight. Because of the water (moisture) present in most samples, calculation of the recovery of sample analyte concentrations should account for this source of dilution.

7.3.3 Preparation of Containers for Vapor Partitioning—Container preparation applies to both field and laboratory sample preparation. This method allows for the direct analysis of a sample by either purge-and-trap or headspace techniques. In both cases, the sample is placed into a VOA vial from which the vapor (only a portion for headspace analysis) is removed for analysis without the container being opened. Moreover, water that contains no detectable levels of VOCs and if required a PTFE or glass coated stir bar should be present in the VOA vial prior to introducing the sample. Current automated equipment for purge-and-trap and headspace systems use 44- (or 40-) typically use 40 and 22-mL VOA vials, respectively. The volume of water used for these two different systems is typically 10 mL or less. Furthermore, the tared weight of the container should be recorded prior to adding the sample. The difference in weight of the container, measured before and after the sample is added, is used to determine the sample's wet weight.

7.3.4 *Preparation of Samples Transported and Stored in Solventless VOA Vials or Bottles*—When samples are held in a VOA vial or bottle, methanol can be added to the container by piercing the septum. In the case of a 5-g sample contained in a 40-mL VOA vial, 5.0 mL of ~~methanol~~ methanol can be added without over pressurization. When larger samples and bottles, or both, are used, experimental trials should be performed to establish what volume of solution can be added. If performed manually, a 0.635 mm nominal outer diameter and 0.318 nominal inner diameter or smaller needle (see Note 1) should be used to add the methanol. After the methanol is introduced, the soil sample should be dispersed. If the sample is held beyond the laboratory-prescribed extraction and analysis period (typically 24 h or less), it is recommended that either the pierced septum be replaced with one that is intact or that an aliquot of the methanol be transferred to an appropriate vessel for storage. If the pierced septum is replaced, it should be replaced with one that is intact by replacing the cap of the vial or bottle with a cap having an intact septum. When the laboratory prescribed extraction method uses elevated temperatures, or sonication, or both, it is recommended that the pierced septum be replaced prior to this treatment. To limit the loss of VOCs when replacing the cap or transferring an aliquot of methanol, the container should be cooled to $4 \pm 2^\circ\text{C}$, and these functions should be performed as quickly as possible. Cooling the sample lowers the vapor pressure of the analytes of interest and reduces the pressure created by adding the methanol. By having methanol present in the collection vessel prior to introducing the sample, the additional precautions associated with a pierced septum can be avoided. In addition, having methanol present in the collection vessel reduces the possibility of VOCs being lost during the transfer step (that is, extrusion of a plug of soil from the sampling tool into the empty vessel).

NOTE 1—This is a 23-gage needle.

8. Sample Collection

8.1 *General Sampling Guidance*—Using an appropriate sized coring tool (see below), collect samples from freshly exposed surfaces of the soil or waste with minimal disturbance. The soil or waste to be sampled may be from an intact pit face or the relatively undisturbed contents in a split-barrel sampler, a core barrel liner, or a liner from a single or double tube direct push sampling system. Before sampling, remove several centimeters of material to expose a fresh surface. Obtain a sample by pressing (or hammering in a few cases) the end of the coring tool into the pit face or into the end or side of a larger core sample. Remove the coring tool. The optimum diameter of the coring tool depends on the following: size of the opening on the collection vial or bottle (tool should fit inside mouth), particle size of the solid materials (for example, gravel-size particles would require larger samplers), and volume of sample required for analysis. For example when a 5-g sample of soil is specified, only a single 3-cm³ volume would need to be collected (assuming the soil has density of 1.7 g/cm³). Larger sample masses or composite samples may be preferred as the heterogeneity of the material increases.

8.1.1 *Sampling of Cohesive but Uncemented Materials Using Devices Designed to Obtain a Sample Appropriate for Analysis*—Collect appropriate size sample for analysis using a metal or rigid plastic coring tool (see Figs. 3 and 4). For example, coring tools for the purpose of transferring a sample can be made from disposable plastic syringes by cutting off the tapered front end and removing the rubber cap from the plunger. Pre-fabricated plastic syringes/coring tools are available commercially. This type of coring device is not appropriate for sample storage. These smaller coring devices help maintain the sample structure during collection and transfer to the VOA vial or a larger bottle. When inserting a clean coring tool into a fresh surface for sample collection, air should not be trapped behind the sample. If air is trapped, it could either pass through the sampled material causing VOCs to be lost or cause the sample to be pushed prematurely from the coring tool. For greater ease in pushing coring tools into the solid matrix, their front edge can be sharpened.

8.1.2 Obtain an undisturbed sample by pushing the barrel of the coring tool into a freshly exposed surface and removing the corer once filled. Clean the exterior of the barrel by wiping with a clean disposable towel. If the coring tool is an En-Coresampler and it is used as a storage container, cap the open end after ensuring that the sealing surfaces are cleaned (see 9.1.1). If the device is solely used for collection and not storage, immediately extrude the sample into a tared VOA vial or bottle by gently pushing the plunger. During transfer of the sample into the container, care should be taken to prevent the sample from contacting the sealing surfaces which can compromise these surfaces and prevent an airtight seal. The volume of material collected should not cause excessive stress on the coring tool during intrusion into the material, or be so large that the sample easily falls apart during extrusion. Obtaining and transferring a sample should be done rapidly (<10 s) to reduce volatilization losses. If the vial or bottle contains methanol or another liquid, it should be held at an angle when extruding the sample into the container to minimize splashing. Just before capping, a visual inspection of the lip and threads of the sample vessel should be made, and any foreign debris should be removed with a clean towel, allowing an airtight seal to form.

8.2 *Devices That Can be Used for Sampling a Cemented Material*—Samples of hard or cementitious material may be obtained by fragmenting a larger portion of the material using a clean chisel to generate aggregate(s) of a size that can be placed into a tared VOA vial or bottle. When transferring the aggregate(s), precautions must be taken to prevent compromising the sealing surfaces and threads of the container. Losses of VOCs by using this procedure are dependent on the location of the contaminant relative to the surface of the material being sampled. Therefore, caution should be taken in the interpretation of the data obtained from materials that fit this description. As a last resort when this task can not be performed on-site, a large sample can be collected in a vapor-tight container and transported to the laboratory for further processing (see 9.1 and 9.2). Collecting, fragmenting, and adding the sample to a container should be accomplished as quickly as possible.