



Designation: **C1168 – 08 C1168 – 15**

Standard Practice for Preparation and Dissolution of Plutonium Materials for Analysis¹

This standard is issued under the fixed designation C1168; the number immediately following the designation indicates the year of original adoption or, in the case of revision, the year of last revision. A number in parentheses indicates the year of last reapproval. A superscript epsilon (ϵ) indicates an editorial change since the last revision or reapproval.

1. Scope

1.1 This practice is a compilation of dissolution techniques for plutonium materials that are applicable to the test methods used for characterizing these materials. Dissolution treatments for the major plutonium materials assayed for plutonium or analyzed for other components are listed. ~~Aliquants~~ Aliquots of the dissolved samples are dispensed on a weight basis when one of the analyses must be highly reliable, such as plutonium assay; otherwise they are dispensed on a volume basis.

1.2 Procedures in this practice are intended for the dissolution of plutonium metal, plutonium oxide, and uranium-plutonium mixed oxides. Aliquots of dissolved samples are analyzed using test methods, such as those developed by Subcommittee C26.05 on Methods of Test, to demonstrate compliance with applicable requirements. These may include product specifications such as Specifications C757 and C833.

1.3 One or more of the procedures in this practice may be applicable to unique plutonium materials, such as alloys, compounds, and scrap materials. The user must determine the applicability of this practice to such materials.

1.4 The treatments, in order of presentation, are as follows:

Procedure Number	Procedure Title	Section
<u>1</u>	Dissolution of Plutonium Metal with Hydrochloric Acid at Room Temperature	<u>9</u>
<u>2</u>	Dissolution of Plutonium Metal with Hydrochloric Acid and Heating	<u>10</u>
<u>3</u>	Dissolution of Plutonium Metal with Sulfuric Acid	<u>11</u>
<u>4</u>	Dissolution of Plutonium Oxide and Uranium-Plutonium Mixed Oxide by the Sealed-Reflux Technique	<u>12</u>
<u>5</u>	Dissolution of Plutonium Oxide and Uranium-Plutonium Mixed Oxides by Sodium Bisulfate Fusion	<u>13</u>
<u>6</u>	Dissolution of Uranium-Plutonium Mixed Oxides and Low-Fired Plutonium Oxide in Beakers	<u>14</u>
<u>7</u>	Open-Vessel (with Reflux Condenser) Dissolution of Plutonium Oxide Powder	<u>15</u>
<u>8</u>	Open-Vessel (with Reflux Condenser) Dissolution of Mixed Oxide Powder	<u>16</u>
<u>9</u>	Closed-Vessel Hot Block Dissolution of Plutonium Oxide Powder	<u>17</u>
<u>10</u>	Open-Vessel (with Reflux Condenser) Dissolution of Mixed Oxide Pellets	<u>18</u>
	Procedure Title	Section
	Dissolution of Plutonium Metal with Hydrochloric Acid	9-1
	Dissolution of Plutonium Metal with Sulfuric Acid	9-2
	Dissolution of Plutonium Oxide and Uranium-Plutonium Mixed Oxide by the Sealed-Reflux Technique	9-3
	Dissolution of Plutonium Oxide and Uranium-Plutonium Mixed Oxides by Sodium Bisulfate Fusion	9-4
	Dissolution of Uranium-Plutonium Mixed Oxides and Low-Fired Plutonium Oxide in Beakers	9-5

¹ This practice is under the jurisdiction of ASTM Committee C26 on Nuclear Fuel Cycle and is the direct responsibility of Subcommittee C26.05 on Methods of Test. Current edition approved Jan. 1, 2008; Sept. 1, 2015. Published February 2008; October 2015. Originally approved in 1990. Last previous edition approved in 2004 as C1168 – 01; C1168 – 08. DOI: 10.1520/C1168-08; 10.1520/C1168-15.

1.5 The values stated in SI units are to be regarded as standard. Values in parentheses (non-SI units), where provided, are for information only and are not considered standard.

1.6 This standard does not purport to address all of the safety concerns, if any, associated with its use. It is the responsibility of the user of this standard to establish appropriate safety and health practices and determine the applicability of regulatory limitations prior to use.

2. Referenced Documents

2.1 ASTM Standards:²

[C757 Specification for Nuclear-Grade Plutonium Dioxide Powder, Sinterable](#)

[C833 Specification for Sintered \(Uranium-Plutonium\) Dioxide Pellets](#)

[C859 Terminology Relating to Nuclear Materials](#)

[C1145 Terminology of Advanced Ceramics](#)

[C1210 Guide for Establishing a Measurement System Quality Control Program for Analytical Chemistry Laboratories Within the Nuclear Industry](#)

~~[E1008D1193 Specification for Sintered \(Uranium-Plutonium\) Dioxide Pellets—Fast Reactor Fuel Reagent Water](#)~~ (Withdrawn 2014)

[D7439 Test Method for Determination of Elements in Airborne Particulate Matter by Inductively Coupled Plasma—Mass Spectrometry](#)

[E1154 Specification for Piston or Plunger Operated Volumetric Apparatus](#)

2.2 ISO Standards:³

[ISO 8655 Piston-Operated Volumetric Instruments \(6 parts\)](#)

3. Terminology

3.1 *Definitions*—~~For~~ Except as otherwise defined herein, definitions of terms used in this standard, refer to are as given in Terminology C859.

3.2 *Definitions of Terms Specific to This Standard:*

3.2.1 *calcination, n—(calcine, v)*—firing or heating of a granular or particulate solid at less than fusion temperature, but sufficient to remove most of its chemically combined volatile matter and otherwise to develop the desired properties for use. **C1145**

3.2.2 *reagent blank, n*—solution containing all reagents used in sample preparation, in the same quantities used for preparation of blank and sample solutions. **D7439**

4. Summary of Dissolution Methods Procedures

4.1 Most plutonium-containing samples are dissolved with various mineral acids and, except for plutonium metal, with applied heat. ~~Dissolution-resistant~~ In some cases, dissolution-resistant materials are dissolved in heated and sealed containers in which pressurization provides a higher temperature than is attained at ambient pressure.

~~4.2 Another dissolution technique is fusion of refractory plutonium oxide with sodium bisulfate flux.~~

4.2 The dissolved materials are quantitatively transferred to a tared polyethylene dispensing bottle for subsequent deliveries of ~~weight aliquants~~ weighed aliquots for high-precision analysis methods, such as assays, or to a volumetric flask for deliveries of ~~volume aliquants~~ aliquots for less precise analysis methods, such as impurity analyses. ~~Acids, usually 1 M,~~ Dilute acids are used as rinses to effect quantitative transfers and as diluents in the polyethylene dispensing bottles and volumetric flasks. The use of water for these purposes can, in some cases, result in hydrolysis of plutonium to produce polymers that, although soluble, are nonreactive in separation treatments or in plutonium assay methods that have no pretreatments, such as fuming with acid.

4.3 The procedures included in this practice are briefly described in 4.4 through 4.8. Other dissolution reagents are possible, but are not addressed in this practice. When alternate reagents are employed, the user shall verify their suitability for the intended use.

4.4 Plutonium metal is dissolved with hydrochloric acid (Section 9 or 10) or with sulfuric acid (Section 11).

4.5 Plutonium oxide, calcined at about 1000°C or lower, is dissolved with a mixture of hydrochloric, nitric, and hydrofluoric acids using the sealed-reflux techniques (Section 12) (1).⁴ More refractory plutonium oxide is dissolved with a fusion using sodium bisulfate flux (Section 13) (2). ~~Low-fired (<650°C) plutonium oxide can also be dissolved in a mixture of nitric and hydrofluoric acids in beakers. Plutonium oxide fired at temperatures above 650°C may also be dissolved in beakers using a mixture of nitric and hydrofluoric acids when complete dissolution can be demonstrated.~~

² For referenced ASTM standards, visit the ASTM website, www.astm.org, or contact ASTM Customer Service at service@astm.org. For *Annual Book of ASTM Standards* volume information, refer to the standard's Document Summary page on the ASTM website.

³ The last approved version of this historical standard is referenced on www.astm.org. Available from International Organization for Standardization (ISO), ISO Central Secretariat, Chemin de Blandonnet 8, CP 401, 1214 Vernier, Geneva, Switzerland, <http://www.iso.org>.

⁴ The boldface numbers in parentheses refer to a list of references at the end of this practice.

4.6 A mixture of nitric and hydrofluoric acid in beakers can be used for low-fired (<650°C) plutonium oxide (Section 14). Open-vessel dissolution using nitric and hydrofluoric acids can be used for low-fired plutonium oxide (Section 15) or mixed oxide (Section 16). Closed-vessel hot block dissolution can also be used for low-fired plutonium oxide (Section 17). Plutonium oxide fired at temperatures above 650°C may also be dissolved using one of the methods described in Sections 14 through 17 when complete dissolution can be demonstrated.

4.7 Uranium-plutonium mixed oxide is dissolved in ~~either any of three ways:~~ the following ways: by the sealed-reflux technique using a mixture of hydrochloric, nitric, and hydrofluoric acids (Section 12), by sodium bisulfate fusion, fusion (Section 13), by a heated mixture of nitric and hydrofluoric acids in a beaker, beaker (Section 14 or a mixture of hydrochloric, nitric, and hydrofluoric acids in a beaker, beaker (Section 14), or by open-vessel dissolution using nitric and hydrofluoric acids by (Section 16) the sealed-reflux technique.

4.8 Mixed oxide pellets are dissolved using open-vessel dissolution with nitric and hydrofluoric acids (Section 18).

4.9 Combinations of these dissolution techniques described in ~~4.4 to the preceding~~ 4.6 paragraphs are sometimes used on difficult-to-dissolve samples.

4.10 Quantitative transfers of samples and subsequent solution are required. Whenever a loss is incurred or even suspected, the sample is rejected. Solutions of dissolved samples are inspected for undissolved particles; if particles are present, further treatment is necessary to attain complete solubility. When analyzing the dissolved sample for trace impurities, caution should be exercised so the dissolution process does not cause the impurity to be lost or does not significantly increase the level of impurity being determined.

5. Significance and Use

5.1 ~~The materials covered are plutonium metal, plutonium oxide, and uranium-plutonium mixed oxide, including those that must meet ASTM product specifications:~~

5.1 Plutonium and uranium mixtures are used as nuclear reactor fuels. For use as a nuclear reactor fuel, the material must meet certain criteria for combined uranium and ~~pluto-~~plutonium content, effective fissile content, and impurity content as described in Specifications ~~C757; C833, and and C1008~~C833. The After dissolution using one of the procedures described in this practice, the material is assayed for plutonium and uranium to determine if the content is correct as specified by the purchaser.

5.2 ~~The materials not covered are unique plutonium materials, including Unique plutonium materials, such as alloys, compounds, and scrap materials. The user must determine the applicability of this practice to these other materials. In general, these unique plutonium materials are metals, are typically dissolved with various acid mixtures or by fusion with various fluxes. Many plutonium salts are soluble in hydrochloric acid. One or more of the procedures included in this practice may be effective for some of these materials; however their applicability to a particular plutonium material shall be verified by the user.~~

<https://standards.iteh.ai/catalog/standards/sist/b75d9c6c-e19c-406e-8e01-19cfc0eb55c6/astm-c1168-15>

6. Apparatus

6.1 Ordinary laboratory apparatus are not listed, but are assumed to be present.

6.2 ~~Balances, for weighing samples and solutions. A balance with a sensitivity of 0.1 mg is necessary; however, a balance with 0.01 mg sensitivity is more desirable. A calibrated balance must be~~ The following items are used by most or all procedures listed herein. Apparatus specific to one, or a few, procedures are listed under the specific procedures where they are used.

6.2.1 ~~Balances, for weighing samples and solutions. A balance with a sensitivity of 0.1 mg is necessary; however, a balance with 0.01 mg sensitivity is more desirable. A calibrated balance must be used.~~

6.2.2 ~~Beakers and Erlenmeyer Flasks—Generally, borosilicate glass is recommended; however, the analyst should be sure that safety and sample contamination from the container are considered when choosing appropriate containers. For example, when hydrofluoric acid is used, the use of borosilicate glass may be avoided due to etching.~~

6.2.3 Volumetric flasks or polyethylene dispensing bottles, for collecting the final solution from which aliquots are dispensed.

6.2.4 File or brush, for cleaning plutonium metal surfaces (used in Sections 9 through 11).

6.2.5 Inert Atmosphere Glove-Box System—capability of maintaining less than 10 ppm of H₂O and 2 % of O₂ is preferred.

6.2.6 Piston-Operated Volumetric Pipettors, complying with the requirements of Specification E1154, applicable portions of ISO 8655 (six parts), or both.

6.2 ~~Beakers, Test Tubes, and Erlenmeyer Flasks—Generally, borosilicate glass is recommended; however, the analyst should be sure that safety and sample contamination from the container are considered when choosing appropriate containers.~~

6.3 ~~Furnace, with controller for timed operation. The furnace must be capable of maintaining an even temperature of ±10°C up to 700°C.~~

6.4 ~~Heating Equipment—Hot plates and infrared lamps are used.~~

6.5 Inert Atmosphere Glove-Box System—capability of maintaining less than 10 ppm of H₂O and of O₂ is preferred.

6.6 *Sealed-Reflex Dissolution Apparatus*—The example apparatus is shown in Fig. 1 and Fig. 2 and is further described in Ref (1):

6.6.1 *Stopper*—A stopper which will not react with the dissolution matrix must be used. A solid stopper inserted in a hollow, polyethylene stopper liner has been found to be satisfactory. Certain fluorinated elastomers, designated as FKMs, have also found to be satisfactory.

7. Reagents

NOTE 1—Use distilled or demineralized water for Reagents used in specific procedures are listed within the procedure or procedures where they are used. The following information applies to all reagents.

7.1 *Hydrochloric Acid, concentrated* (sp gr 1.18), 12 M.

7.2 *Hydrochloric Acid, 6 M*—Add 500 mL of 12 M HCl to <500 mL of water and dilute to 1 L with water.

7.3 *Hydrochloric Acid, 1 M*—Add 83 mL of 12 M HCl to <900 mL of water and dilute to 1 L with water.

7.4 *Hydrofluoric Acid, concentrated* (sp gr 1.17), 28 M.

7.5 *Hydrofluoric Acid, 1.3 M*—Transfer 4.8 mL of 28 M HF, using a plastic pipet, to a 100-mL plastic graduated cylinder containing <90 mL of water and dilute to 100 mL with water. Transfer to a plastic bottle for storage.

7.6 *Hydrofluoric Acid-Nitric Acid Mixture, 0.05 M HF-16 M HNO₃*—Add 1.8 mL 28 M HF, using a plastic pipet, to 1 L of 16 M HNO₃.

7.7 *Nitric Acid, concentrated* (sp gr 1.42), 16 M.

7.8 *Nitric Acid, 1 M*—Add 62 mL of 16 M HNO₃ to <900 mL of water and dilute to 1 L with water.

7.1 *Sodium Bisulfate, Anhydrous, Fused, NaHSO₄* Purity of Reagents—Grind the sodium bisulfate to a fine powder just before use, if necessary. All reagents used should be of the highest purity available. Other grades may be used if they are determined not to affect the final result.

7.10 *Sulfuric Acid, concentrated* (sp gr 1.84), 18 M.

7.2 *Sulfuric Acid, Purity of Water*—0.5 Unless otherwise indicated, Cautiously add 28 mL of 18 references M H₂SO₄ to water and dilute to 1 L with water. shall be understood to mean reagent water, as defined by Type I of Specification D1193.

8. Precautions

8.1 Strong acids are used during this analysis. by these dissolution procedures. Safety glasses and gloves must be worn when handling these solutions. Extreme care should be exercised in using hydrofluoric acid and other hot concentrated acids. Acid solutions are evaporated during this analysis. by these dissolution procedures. These operations must be conducted in a fume hood.

<https://standards.iteh.ai/catalog/standards/sist/b75d9c6c-c19c-406e-8e01-f9cf0eb55c6/astm-c1168-15>

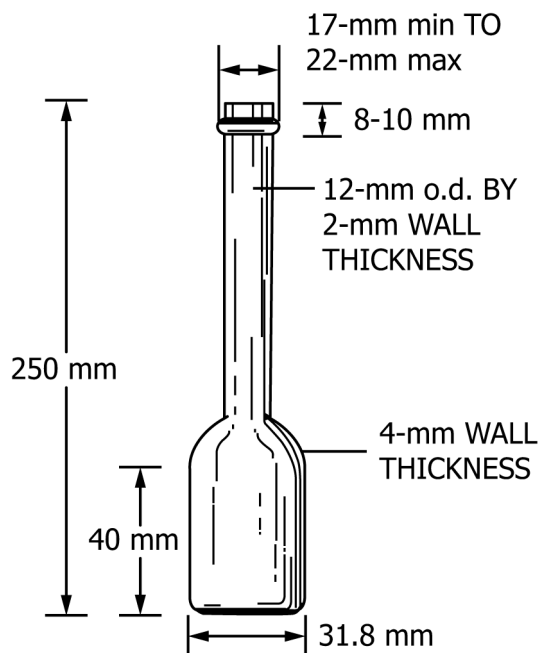

FIG. 1 Sealed-Reflex Dissolution Tube

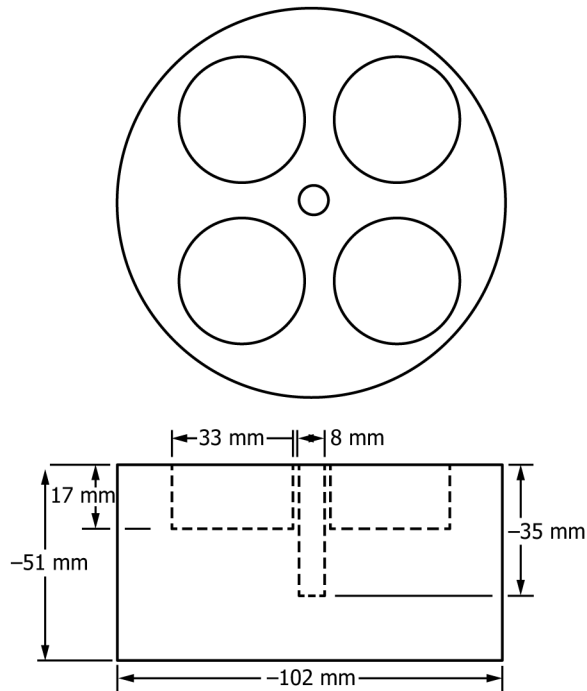

FIG. 2 Heating Block

8.2 Hydrofluoric acid is a highly corrosive and toxic acid that can severely burn skin, eyes, and mucous membranes. Hydrofluoric acid differs from other acids because the fluoride ion readily penetrates the skin, causing destruction of deep tissue layers. Unlike other acids that are rapidly neutralized, hydrofluoric acid reactions with tissue may continue for days if left untreated. Utilization of appropriate laboratory controls and wearing adequate personal protective equipment to protect from skin and eye contact familiarization and compliance with the Safety Data Sheet is essential.

8.3 Extreme care is required when using procedures that involve closed vessels, pressurization, or both (Sections 12 and 17). Potential explosions or rupturing of vessels could injure personnel or breach glovebox containment, or both. Appropriate controls are required to prevent pressure or temperature from exceeding prescribed by safety limits.

9. Procedure 1 – Dissolution of Plutonium Metal with Hydrochloric Acid at Room Temperature

9.1 Apparatus:

9.1.1 Hot Plate, thermostatically controlled, capable of maintaining a surface temperature of up to at least 200°C.

NOTE 2—The surface temperature of a hot plate can vary considerably with position on hot plates with large surface areas. It is therefore recommended that the performance of the hot plate be characterized before use.

9.1.2 Centrifuge Tube, optional, to receive weighed sample if beaker is not used.

9.1.3 Watch glasses.

9.1.4 Infrared lamp.

9.2 Reagents:

9.2.1 Hydrochloric Acid, concentrated (sp gr 1.18), 12 M.

9.2.2 Hydrochloric Acid, 6 M—Add 500 mL of 12 M HCl to <500 mL of water and dilute to 1 L with water.

9.2.3 Hydrochloric Acid, 1 M—Add 83 mL of 12 M HCl to <900 mL of water and dilute to 1 L with water.

9.2.4 Hydrofluoric Acid, concentrated (sp gr 1.17), 28 M.

9.2.5 Hydrofluoric Acid, 1.3 M—Transfer 4.8 mL of 28 M HF, using a plastic pipet, to a 100-mL plastic graduated cylinder containing <90 mL of water and dilute to 100 mL with water. Transfer to a plastic bottle for storage.

9.2.6 Nitric Acid, concentrated (sp gr 1.42), 16 M.

9.3 Procedure:

9.3.1 Remove surface oxide, if present, from the bulk sample before cutting into portions. Removal of surface oxide may be performed by filing or brushing the plutonium metal, or by using other mechanical or chemical means.

NOTE 3—Plutonium metal reacts with air and moisture to form PuO₂. An inert-atmosphere glovebox system can be utilized for mechanical removal of surface oxide, but is not recommended for removal by chemical means. Use of an inert-atmosphere glovebox system is recommended when preparing standards or tracers.

9.3.2 Weigh a representative sample size, considering the required uncertainty and the analysis method to be used. Normal sample size is 50 to 700 mg, but this may vary. A certified sample mass, if known, may be used in lieu of weighing.

9.3.3 Transfer the weighed sample to a beaker or centrifuge tube and cover with a watch glass.

9.3.4 Add 6 M HCl dropwise, or in small portions, through the spout of the beaker or centrifuge tube until the sample dissolves completely.

9.3.5 Inspect the solution for suspended particles or deposited solid and, if present, warm the solution (using, for example, an infrared lamp).

9.3.6 If solid still is present, add 0.5 mL 16 M HNO₃ and three drops 1.3 M HF, and heat until dissolution is complete.

9.3.7 Quantitatively transfer the solution using at least four rinses of the watch glass and beaker or centrifuge tube with 1 M HCl. Transfer to a volumetric flask and bring to volume using 1 M HCl. Alternatively, for high-precision analyses, transfer to a previously tared polyethylene dispensing bottle, weigh the bottle with the solution, and calculate the weight difference to determine final volume.

9.3.8 Mix the solution, equilibrate to room temperature, and dispense aliquots for analysis.

10. Procedure 2 – Dissolution of Plutonium Metal with Hydrochloric Acid and Heating

10.1 This procedure is for Pu metal pieces of approximately 0.5 g mass which may be conditioned under an inert atmosphere glovebox system.

10.2 Apparatus:

10.2.1 *Hot Plate:* thermostatically controlled, capable of maintaining a surface temperature of up to at least 200°C.

NOTE 4—The surface temperature of a hot plate can vary considerably with position on hot plates with large surface areas. It is therefore recommended that the performance of the hot plate be characterized before use.

10.2.2 *Watch glasses.*

10.3 Reagents:

10.3.1 *Hydrochloric Acid*, concentrated (sp gr 1.18), 12 M.

10.3.2 *Hydrochloric Acid*, 1 M—Add 83 mL of 12 M HCl to <900 mL of water and dilute to 1 L with water.

10.3.3 *Hydrochloric Acid*, 0.1 M—Add 8.3 mL of 12 M HCl to <900 mL of water and dilute to 1 L with water.

10.3.4 *Hydrofluoric Acid*, concentrated (sp gr 1.17), 28 M.

10.3.5 *Hydrofluoric Acid*, 1 M—Transfer 3.6 mL of 28 M HF, using a plastic pipet, to a 100-mL plastic graduated cylinder containing <90 mL of water and dilute to 100 mL with water. Transfer to a plastic bottle for storage.

10.4 Procedure:

10.4.1 Remove surface oxide, if present, from the bulk sample before cutting into portions. Removal of surface oxide may be performed by filing or brushing the plutonium metal, or by using other mechanical or chemical means.

NOTE 5—Plutonium metal reacts with air and moisture to form PuO₂. An inert-atmosphere glovebox system can be utilized for mechanical removal of surface oxide, but is not recommended for removal by chemical means. Use of an inert-atmosphere glovebox system is recommended when preparing standards or tracers.

10.4.2 Weigh a representative sample size, considering the required uncertainty and the analysis method to be used. A certified sample mass, if known, may be used in lieu of weighing.

10.4.3 Transfer the weighed sample to a beaker or Erlenmeyer flask, add just enough 0.1 M HCl to cover the metal, then slowly add 7 to 8 mL of 12 M HCl and cover with a watch glass.

10.4.4 Allow the metal to dissolve for 10 to 15 min at room temperature.

10.4.5 Inspect the solution for suspended particles or deposited solid and, if present, add an additional 2 mL of 12 M HCl and heat to boiling for 2 h.

10.4.6 If solid is still present, add an additional 2 mL of 12 M HCl and 2 drops of 1M HF, and heat for an additional 2 h.

10.4.7 Repeat step 10.4.6 as necessary until dissolution is complete.

10.4.8 Quantitatively transfer the solution using at least four rinses of the watch glass and beaker or centrifuge tube with 1 M HCl. Transfer to a volumetric flask and bring to volume using 1 M HCl. Alternatively, for high-precision analyses, transfer to a previously tared polyethylene dispensing bottle, weigh the bottle with the solution, and calculate the weight difference to determine final volume.

10.4.9 Mix the solution, equilibrate to room temperature, and dispense aliquots for analysis.

11. Procedure 3 – Dissolution of Plutonium Metal with Sulfuric Acid

11.1 Apparatus:

11.1.1 *Infrared lamp.*

11.1.2 *Watch glasses.*

11.1.3 *Magnetic stirrer* with TFE-fluorocarbon stir bar.

11.2 Reagents: