



Standard Specification for Expanded-Metal Doors¹

This standard is issued under the fixed designation F 1072; the number immediately following the designation indicates the year of original adoption or, in the case of revision, the year of last revision. A number in parentheses indicates the year of last reapproval. A superscript epsilon (ϵ) indicates an editorial change since the last revision or reapproval.

1. Scope

1.1 This specification covers steel expanded-metal doors suitable for installation in expanded-metal bulkheads, structural bulkheads, and structural arches.

1.2 The values stated in inch-pound units are to be regarded as the standard. The values given in parentheses are for information only.

2. Referenced Documents

2.1 ASTM Standards:

- A 36/A 36M Specification for Carbon Structural Steel²
- A 167 Specification for Stainless and Heat-Resisting Chromium-Nickel Steel Plate, Sheet, and Strip³
- D 3951 Practice for Commercial Packaging⁴
- F 783 Specification for Staple, Handgrab, Handle, and Stir-rung Rung⁵

2.2 Other Documents:

- ABS Rules for Building and Classing Steel Vessels⁶
- AWS D1.1 Structural Welding Code⁷

3. Classification

3.1 Expanded-metal doors are furnished in four types (see Detail “J”) as follows:

- 3.1.1 *Type I*—Right hand (RH).
- 3.1.2 *Type II*—Left hand (LH).
- 3.1.3 *Type III*—Right hand reverse (RHR).
- 3.1.4 *Type IV*—Left hand reverse (LHR).

4. Ordering Information

4.1 Orders for doors under this specification shall include this specification number and type.

5. Materials and Manufacture

5.1 *Materials*—See Table 1.

5.2 *Manufacture*:

5.2.1 Doors shall be furnished with the vertical support channels and top angle in place. A temporary brace shall be included at the frame bottom to prevent racking.

5.2.2 Welding shall be in accordance with AWS D1.1 Structural Welding Code or ABS Rules for Building and Classing Steel Vessels.

6. Installation Requirements

6.1 Doors shall be fitted with rubber-tipped bumpers and a manually operated catch for holding doors in an open position. These shall be furnished and installed by others.

6.2 Provision shall be made for the installation of a rim latch set operated by knobs on both sides. This hardware shall be furnished and installed by others.

6.3 Padlocks shall be furnished by others.

6.4 Any holes needed in the frame for installation in expanded-metal or other types of bulkheads shall be made at installation by others.

7. Dimensions and Tolerances

7.1 Dimensions are as indicated in Figs. 1-8 and Table 1.

7.2 *Tolerance*— $\pm 1/16$ in. (1.5 mm).

8. Workmanship, Finish, and Appearance

8.1 Doors and frames shall be free from all cracks, burrs, sharp edges, and other defects.

8.2 The door manufacturer shall apply a nonhazardous corrosion-inhibiting primer coating to all door assemblies.

9. Packaging and Package Marking

9.1 Each expanded-metal door shall be individually packed for shipment and storage in accordance with Practice D 3951.

9.2 In addition to any special marking required by the contract or purchase order, each expanded-metal door shall be marked in accordance with Practice D 3951.

10. Keywords

10.1 expanded-metal doors; expanded-metal bulkheads; metal doors; structural arches; structural bulkheads

¹ This specification is under the jurisdiction of ASTM Committee F-25 on Ships and Marine Technology and is the direct responsibility of Subcommittee F25.03 on Outfitting.

Current edition approved Feb. 15, 1994. Published April 1994. Originally published as F 1072 – 87. Last previous edition F 1072 – 87.

² *Annual Book of ASTM Standards*, Vol 01.04.

³ *Annual Book of ASTM Standards*, Vol 01.03.

⁴ *Annual Book of ASTM Standards*, Vol 15.09.

⁵ *Annual Book of ASTM Standards*, Vol 01.07.

⁶ Available from American Bureau of Shipping, ABS Plaza 16855 Northchase Dr., Houston, TX 77060.

⁷ Available from American Welding Society, 550 N.W. Le Jeune Rd., Miami, FL 33126.

TABLE 1 Expanded-Metal Door Materials

NOTE 1—1 in. = 25.4 mm.

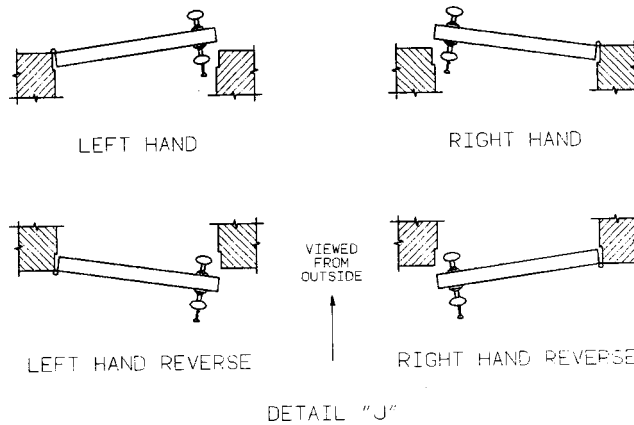

Item Number	Description
1	Frame Top—Angle, $6 \times 3\frac{1}{2} \times \frac{5}{16}$ in., Specification A 36/A 36M.
2	Frame Side—Channel, $C3 \times 5.0$, Specification A 36/A 36M.
3	Staple—Round bar, Specification F 783.
4	Door Frame—Angle, $1\frac{1}{4} \times 1\frac{1}{4} \times \frac{1}{4}$ in., Specification A 36/A 36M.
5	Brace—Flat bar, $2 \times \frac{1}{4}$ in., Specification A 36/A 36M.
6	Cross Brace—Flat bar, $2 \times \frac{1}{4}$ in., Specification A 36/A 36M.
7	Stop—Flat bar, $4 \times \frac{1}{4}$ in., Specification A 36/A 36M.
8	Pad—Flat bar, $4 \times \frac{1}{4}$ in., Specification A 36/A 36M.
9	Hinge—Swaged butt, plain, fixed pin, $3- \times 2\frac{1}{2}$ -in. Type 316 stainless steel, Specification A 167.
10	Expanded Metal—13-gage $\times \frac{1}{2}$ -in. flat pattern, Specification A 36/A 36M.
11	Temporary Brace—Angle $1\frac{1}{4} \times 1\frac{1}{4} \times \frac{1}{4}$ in., Specification A 36/A 36M. (See 5.2.1.)

iTeh S (https://sta Document view

ASTM F1072-94(1999)

/catalog/standards/astm/6e8c7dba-a12f-4112-aa2b-f07ae8329b41/astm-f1072-94-1999