



Designation: **C167—09 C167 – 15**

Standard Test Methods for Thickness and Density of Blanket or Batt Thermal Insulations¹

This standard is issued under the fixed designation C167; the number immediately following the designation indicates the year of original adoption or, in the case of revision, the year of last revision. A number in parentheses indicates the year of last reapproval. A superscript epsilon (ϵ) indicates an editorial change since the last revision or reapproval.

This standard has been approved for use by agencies of the U.S. Department of Defense.

1. Scope

1.1 These test methods cover the determination of thickness and density of flexible, felted, or woven thermal insulating blankets, rolls, or batts composed of fibrous materials, with or without surface covering or reinforcement.

1.2 The values stated in inch-pound units are to be regarded as standard. The values given in parentheses are mathematical conversions to SI units that are provided for information only and are not considered standard.

1.3 *This standard does not purport to address all of the safety concerns, if any, associated with its use. It is the responsibility of the user of this standard to establish appropriate safety and health practices and determine the applicability of regulatory limitations prior to use.*

2. Referenced Documents

2.1 *ASTM Standards:*²

C168 Terminology Relating to Thermal Insulation

3. Terminology

3.1 *Definitions—Terminology C168 shall be considered as applicable to the terms used in these test methods.*

3.2 *Definitions of Terms Specific to This Standard:—Terminology*

3.2.1 *package—an individually wrapped group or bag of batts or a single roll of thermal insulation material. C168 shall be considered as applicable to the terms used in these test methods.*

4. Significance and Use

4.1 Proper measurements of thickness and density of blanket or batt insulations are essential for determining thermal insulation properties. For a particular batt or blanket product, thickness and density are usually directly related to thermal insulating value.

4.2 These test methods are of significant value in manufacturing quality control, to ensure that claimed insulation values of products are maintained.

5. Apparatus

5.1 *Depth Gage, Gauge,* of the type shown in Fig. 1. The disk shall be fabricated of a suitable plastic material. The disk shall have a mass of 9.3 ± 0.3 grams and shall exert a pressure of 0.4 lbf/ft^2 (20 Pa). The disk shall be 3-in. \pm 0.08-in. (76 mm \pm 2mm) in diameter. The disk shall be perpendicular to the pin at all times and shall have a friction device or thumb grip to secure the pin unless purposely moved. The pin shall be made at a maximum $\frac{1}{8}$ -in. (3 mm) diameter. The pin shall be of sufficient length for the material to be measured.

5.2 *Steel rule,* graduated in 0.05-in. or 1-mm intervals.

5.3 *Scales,* of sufficient capacity and sensitivity to weigh the test specimen to an accuracy of ± 0.5 %.

¹ These test methods are under the jurisdiction of ASTM Committee C16 on Thermal Insulation and are the direct responsibility of Subcommittee C16.32 on Mechanical Properties.

Current edition approved April 1, 2009; Sept. 1, 2015. Published April 2009; October 2015. Originally approved in 1941. Last previous edition approved in 2003; 2009 as C167—98 (2003); C167—09. DOI: 10.1520/C0167-09; 10.1520/C0167-15.

² For referenced ASTM standards, visit the ASTM website, www.astm.org, or contact ASTM Customer Service at service@astm.org. For *Annual Book of ASTM Standards* volume information, refer to the standard's Document Summary page on the ASTM website.

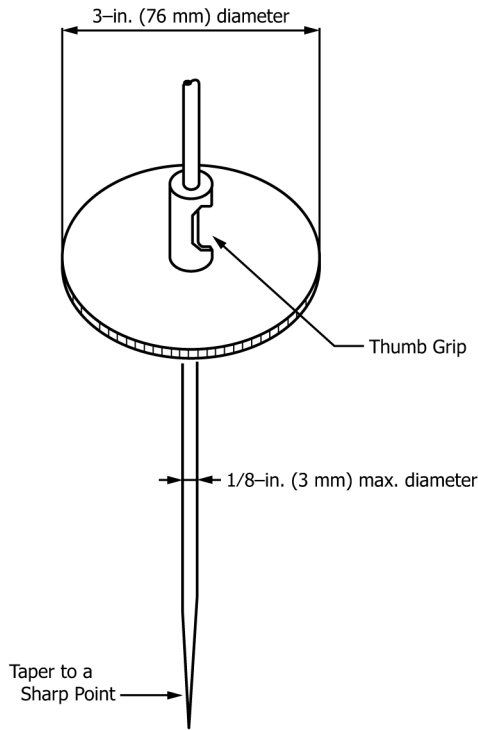

FIG. 1 Depth Gauge for Thickness Measurements

6. Sampling

6.1 A test sample shall consist of one representative roll or bundle package of insulation.

6.2 *Sampling of Packages*—For Sampling of Bundles packages —For bundles which contain 20 or more batts, five batts shall be selected. For bundles packages which contain less than 20 batts, either the three-batt or five-batt selection technique may be used. Batts which are folded in half shall count as two batts for purposes of choosing and employing the selection method.

6.2.1 *Three-Batt Method*—Select Three-Batt Method —Select the center batt and the second batt in from each end of the package.

6.2.2 *Five-Batt Method*—Divide Five-Batt Method —Divide the package sequentially into five groups of batts as equal in number as possible. Select the first batt from each group. Be careful to select one and only one batt from the two end batts within the package.

6.2.3 Cut batts which are longer than 48 in. to 48 ± 0.25 in. (122 ± 0.63 cm) in length.

6.3 *Sampling of Cut Rolls*—Five Sampling of Cut Rolls —Five batts shall be cut of roll-width by 48 ± 0.25 in. (122 ± 0.63 cm) in length.

6.3.1 Cut one batt from the center of the roll, two batts from the ends of the roll, and the fourth and fifth from the quarter points along the length. See Fig. 2.

6.3.2 For blankets wider than 24 in., cut each of the five batts 24 ± 0.25 in. (61 ± 0.63 cm) wide by 48 ± 0.25 in. (122 ± 0.63 cm) long.

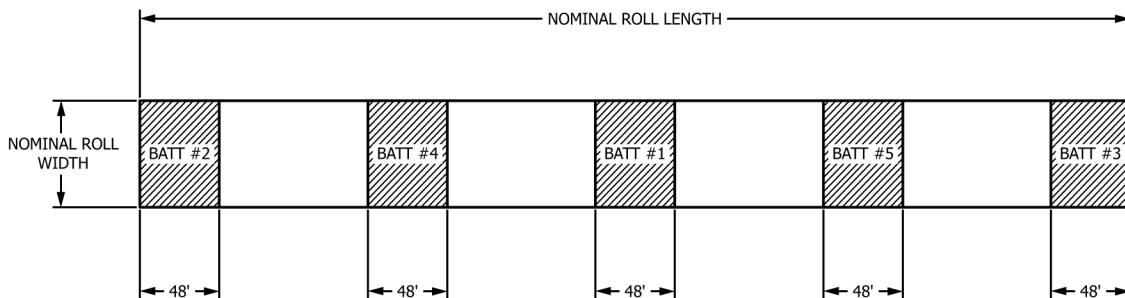

FIG. 2 Sampling of Cut Rolls

6.4 *Sampling for Full Roll Method*—This method can be used in place of 6.3 when the roll is wider than 24 in. (61 cm) or longer than 50 ft (16.4 m). Prior to unrolling the material, weigh the entire roll to the nearest 0.25 pound (0.11 kg). Two methods may be used to obtain the full roll weight. The first method removes the insulation product from the packaging prior to weighing. The material will expand and may unroll slightly, care must be taken to ensure that the full roll is weighed accurately. The second method weighs the packaged insulation product, then weighs the packaging material only. The packaging material weight is subtracted from packaged product weight to obtain net material weight.

7. Procedure

7.1 *Expansion of Bundles/Packages and Cut Roll*—Hold the first batt vertically off the floor by grasping it with both hands on its long dimension so that the lower edge is 18 ± 1 in. (460 ± 25 mm) above a solid horizontal surface. Release the batt, allowing it to strike the surface. Repeat the above for a second time. Next, holding the batt by the other long edge, drop twice as above. Place the specimen on the flat, hard surface. Repeat the above for the remaining four specimens. Allow specimens to reach equilibrium by waiting at least 5 min before making thickness measurements within 1 in. (25 mm) in any direction of five points as indicated in Fig. 3.

NOTE 1—If 23-in. (580-mm) wide samples are tested, use a quarter or half of that dimension to establish the test points.

NOTE 2—Some materials may require 4 h or more to reach equilibrium.

7.2 *Expansion of Full Roll*—Unroll the insulation. Flip the test roll over its entire length so the bottom surface is now on top. Next grasp one end and pull the material over itself until the original surface is again facing up. If there is insufficient room to pull the material over itself (less than twice the unrolled length), the material may be repositioned by sliding the partially pulled roll to the end of the testing space, and continue to pull the material over itself.

NOTE 3—Use 7.1 if sampling procedure in 6.3 is used.

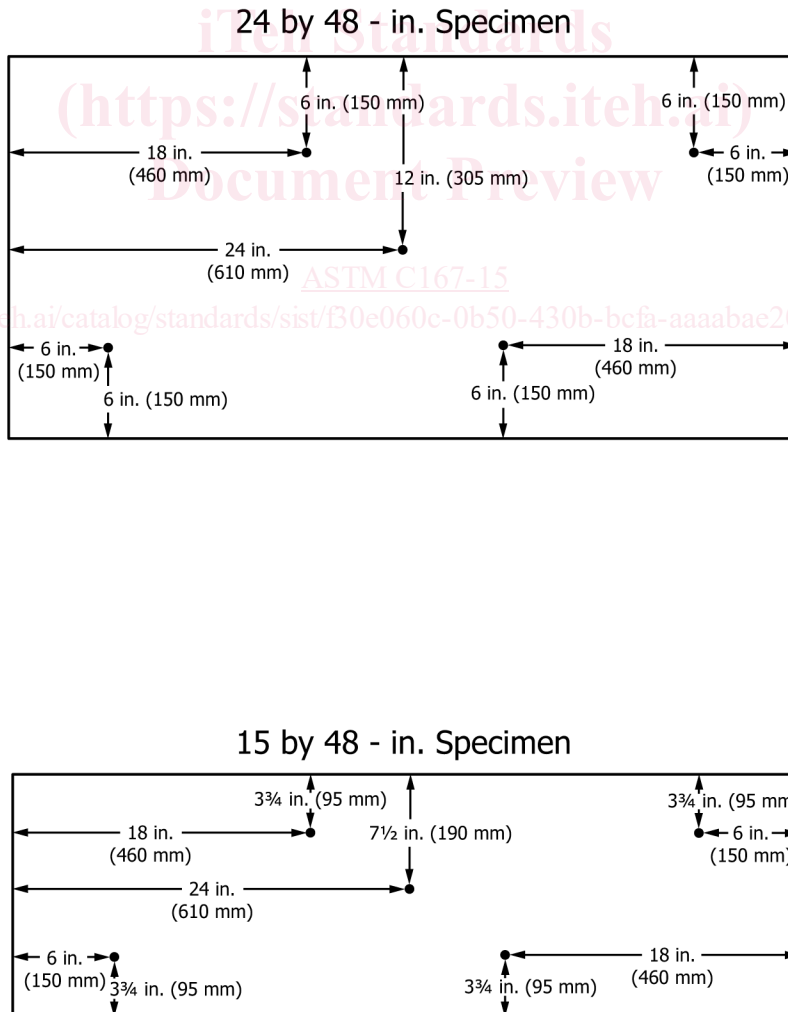

FIG. 3 Thickness Measurement Locations