



## Designation: ~~D6804 – 02 (Reapproved 2011)~~ D6804 – 02 (Reapproved 2015)

# Standard Guide for Hand Hole Design in Corrugated Boxes<sup>1</sup>

This standard is issued under the fixed designation D6804; the number immediately following the designation indicates the year of original adoption or, in the case of revision, the year of last revision. A number in parentheses indicates the year of last reapproval. A superscript epsilon ( $\epsilon$ ) indicates an editorial change since the last revision or reapproval.

## 1. Scope

1.1 This standard provides guidelines for designing pre-cut apertures intended for use as hand holes in corrugated boxes during manual handling of boxed cargo.

1.2 *Limitations*—This standard offers guidance for package development and for subsequent testing of boxes to measure performance. It is not intended to provide specific information on the design of hand holes.

1.3 The values stated in inch-pound units are to be regarded as the standard. The SI units are for information only.

1.4 *This standard does not purport to address all of the safety concerns, if any, associated with its use. It is the responsibility of the user of this standard to establish appropriate safety and health practices and determine the applicability of regulatory requirements prior to use.*

## 2. Referenced Documents

2.1 *ASTM Standards*:<sup>2</sup>

[D585 Practice for Sampling and Accepting a Single Lot of Paper, Paperboard, Fiberboard, and Related Product \(Withdrawn 2010\)](#)<sup>3</sup>

[D996 Terminology of Packaging and Distribution Environments](#)

[D1974 Practice for Methods of Closing, Sealing, and Reinforcing Fiberboard Boxes](#)

[D4332 Practice for Conditioning Containers, Packages, or Packaging Components for Testing](#)

[D5276 Test Method for Drop Test of Loaded Containers by Free Fall](#)

[E4 Practices for Force Verification of Testing Machines](#)

[E122 Practice for Calculating Sample Size to Estimate, With Specified Precision, the Average for a Characteristic of a Lot or Process](#)

## 3. Terminology

3.1 *Definitions*—General definitions for packaging and distribution environments are found in Terminology [D996](#).

3.2 *Definitions of Terms Specific to This Standard*:

3.2.1 *hand holes*—apertures, pre-cut in corrugated boxes by box manufacturers, as requested by box purchasers. These apertures facilitate manual handling during distribution and improve grip during handling.

## 4. Significance and Use

4.1 It may be desirable at times to provide hand holes in corrugated boxes. Package designers use hand holes to solve ergonomic and handling problems associated with large or awkward containers. This guide provides an aid for proper hand hole design and use.

4.2 *Ergonomics*:

4.2.1 In studying and applying ergonomic principles, of primary concern is the need to provide a safe work environment for material handlers who may be required to lift or transport packages. A safe work environment is difficult to define and varies with the package in question. Several ergonomic safety issues involve repetitive motions and spine loading in the lifting process. Other issues involve finger and foot protection.

<sup>1</sup> This guide is under the jurisdiction of ASTM Committee [D10](#) on Packaging and is the direct responsibility of Subcommittee [D10.27](#) on Paper and Paperboard Products. Current edition approved ~~Aug. 1, 2011~~ Oct. 1, 2015. Published ~~November 2011~~ October 2015. Originally approved in 2002. Last previous edition approved in ~~2007~~ 2011 as [D6804 – 02 \(2007\)](#); (2011). DOI: [10.1520/D6804-02R11-10.1520/D6804-02R15](#).

<sup>2</sup> For referenced ASTM standards, visit the ASTM website, [www.astm.org](#), or contact ASTM Customer Service at [service@astm.org](#). For *Annual Book of ASTM Standards* volume information, refer to the standard's Document Summary page on the ASTM website.

<sup>3</sup> The last approved version of this historical standard is referenced on [www.astm.org](#).

4.2.2 In distribution centers or warehouses, low back disorders have been identified as areas of elevated risk. Low back problems continue to represent the most common and costly musculoskeletal disorders in the work place.<sup>4</sup>

4.2.3 One method used to reduce the concern of distance of lift (spinal loading) is to bring the reach of the material handler’s hands closer to the body. With large or awkward boxes, placing hand holes in a more advantageous position can solve this problem.

4.3 NIOSH:

4.3.1 The National Institute for Occupational Safety and Health (NIOSH) has published *Work Practices Guide for Manual Lifting*.<sup>5</sup> This document may be of assistance in developing proper hand holes and their placement for a specific package.

4.4 Improper Use of Hand Holes:

4.4.1 Because of past lawsuits involving the use and misuse of hand holes, the corrugated box industry prefers the term access hole instead of hand hole on specifications. This terminology may have to be agreed upon between supplier and user. **Fig. 1**

<sup>4</sup> “Effects of Box Features on Spine Loading during Warehouse Order Selecting.” Marras, Granata, Davis, Allread, and Jorgensen, The Institute for Ergonomics, Ohio State University.

<sup>5</sup> NIOSH Technical Report No. 81-122 from the US Department of Health and Human Services.

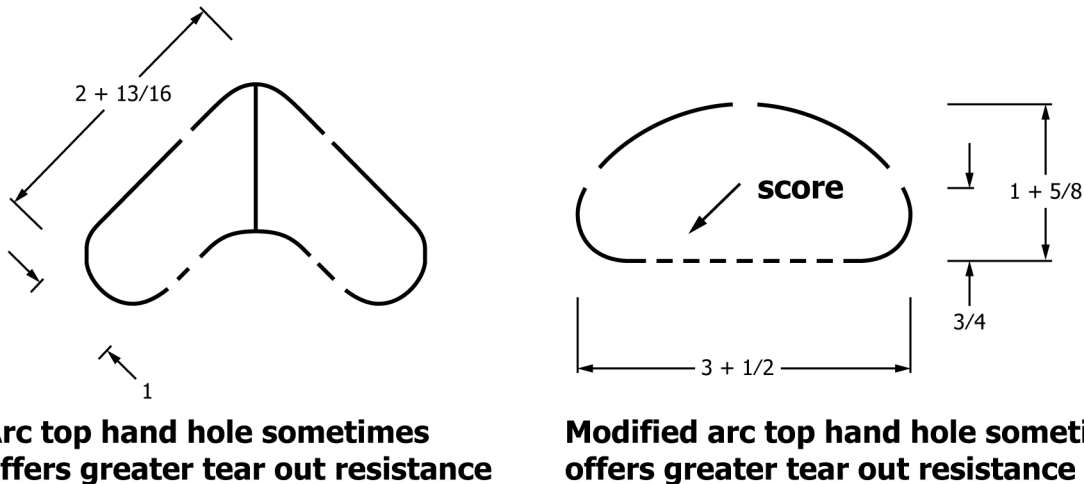
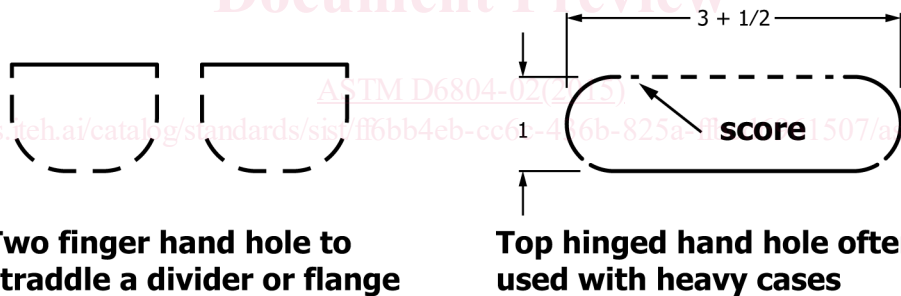
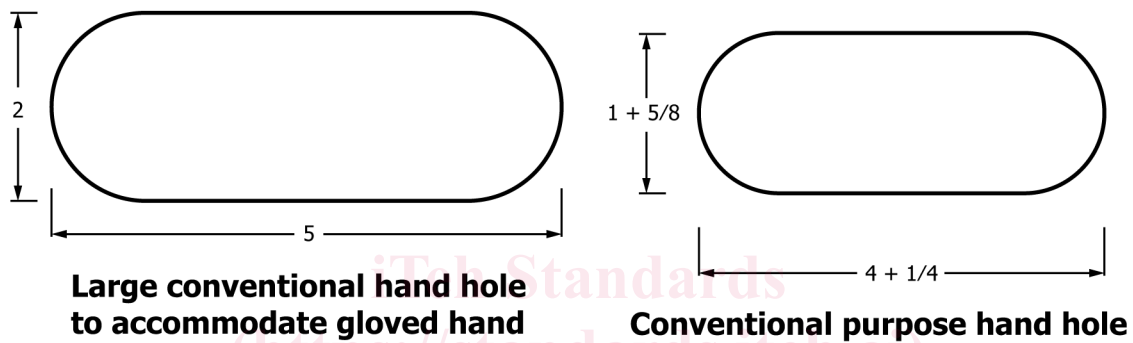

FIG. 1 Common Hand Hole Types

4.4.2 Since all end use conditions and requirements cannot be foreseen and since designing for worst case scenario for all applications is prohibitively expensive, designers should follow best practices. The prudent designer will consider product and package weight when deciding the proper use of a hand hole.

## 5. General Design Considerations

5.1 Hand holes can take many forms (see Fig. 1). They can:

- 5.1.1 Be a simple hole in a box,
- 5.1.2 Be a complex molded handle with a reinforcement mounted at the attaching point,
- 5.1.3 Incorporate rope handles, and
- 5.1.4 Be reinforced by the box maker with reinforcing tape applied above them.

5.2 If possible, position hand holes so that product and internal cushioning material can add support for carrying (see Fig. 2). If the box must bear all the weight, it is best to position the hand holes at least two (2) in. below the horizontal score line of end panels to distribute the compressive forces and avoid failure. When placing hand holes, consider product balance and box closure method.

5.3 Some closure methods, such as taping, can affect hand hole placement. When a hand hole is to be used with a box style such as an RSC, which is to have a tape closure (see Practice D1974), it is best to allow enough room (2 to 2½-in.) for the end-leg of the tape (see Fig. 3). For a Bliss style box, hand holes should be placed just below the top flange (see Fig. 4).

5.4 Several methods are used to reinforce a box above the hand hole. For example, pressure sensitive, heat activated, and adhesive based products can be used. Some have fiberglass or polyester yarn reinforcement, some are tensilized, and some are made of heavy kraft paper (see Fig. 5).

5.5 When possible, use curved type hand holes: they will not tear as easily as the straight top design (see Fig. 4). The curved design eliminates a sharp edge at the corners, resulting in a more evenly distributed lifting force across the surface. Note that a different type of grasping device will be required when testing curved hand holes as opposed to straight ones (see X1.3, Apparatus).

## 6. Evaluation

6.1 The test methods in Appendix X1 are not ASTM standards, but are evaluation methods to assist in determining the relative performance of hand holes during handling in the distribution environment. The methods, in experimental trials, were shown to have high variability between laboratories; however, within laboratories the methods were useful in determining relative performance.

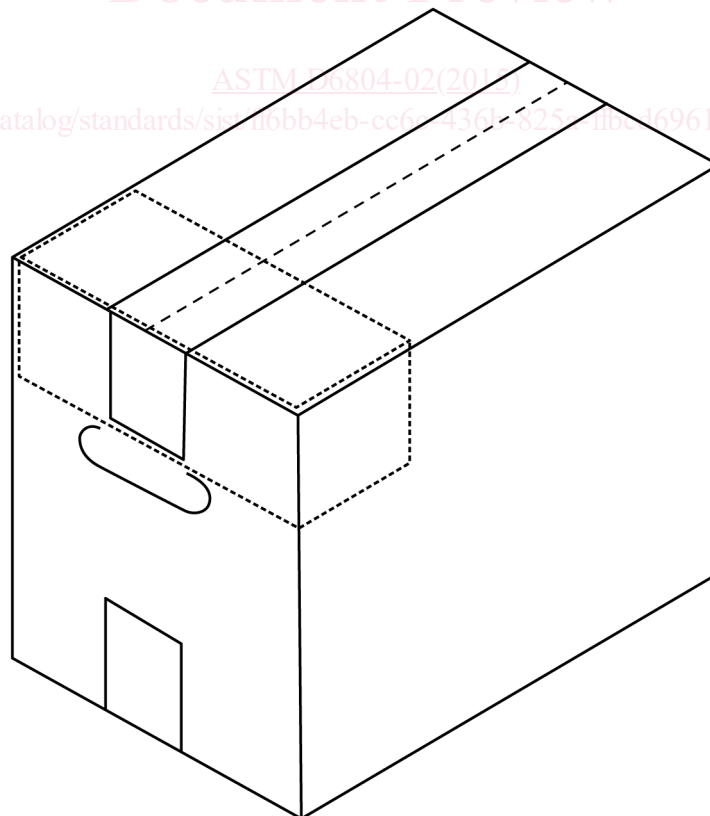

FIG. 2 Box with Internal Cushioning Material, showing location above Hand Hole to provide Added Support for Carrying

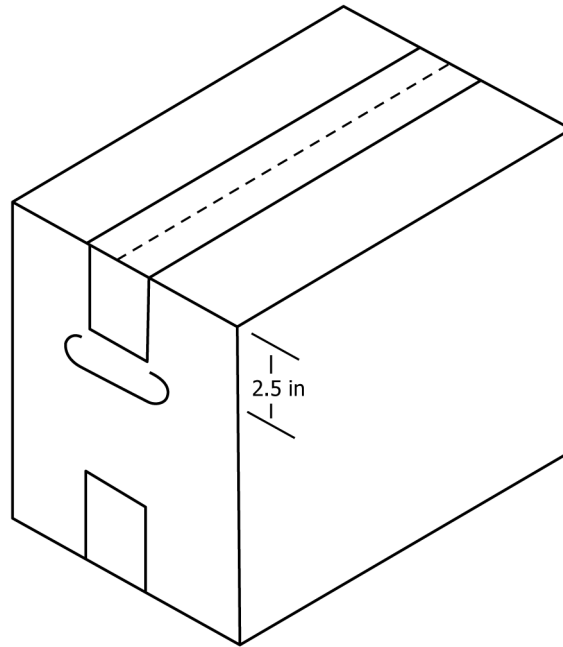

FIG. 3 RSC Style Box with Tape Closure, showing location of Hand Hole 2.5 in. below top edge of box

## 7. Keywords

7.1 corrugated boxes; distribution environment; hand holes; manual handling

iTeh Standards  
(<https://standards.iteh.ai>)  
Document Preview

[ASTM D6804-02\(2015\)](https://standards.iteh.ai/catalog/standards/sist/ff6bb4eb-cc6c-436b-825a-ffbcd6961507/astm-d6804-022015)

<https://standards.iteh.ai/catalog/standards/sist/ff6bb4eb-cc6c-436b-825a-ffbcd6961507/astm-d6804-022015>

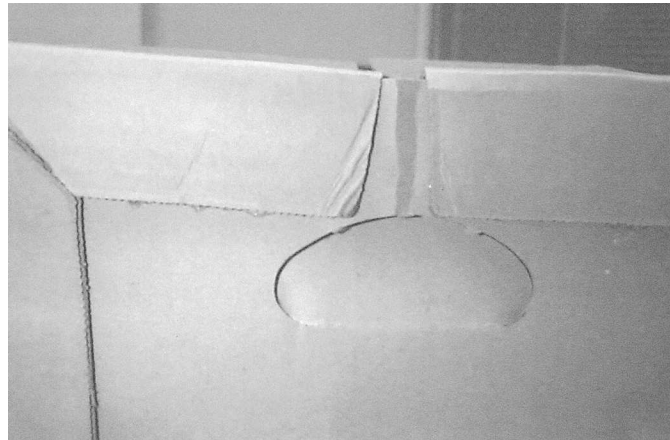

FIG. 4 Bliss Style Box showing Curved Hand Hole located just below the Top Flange

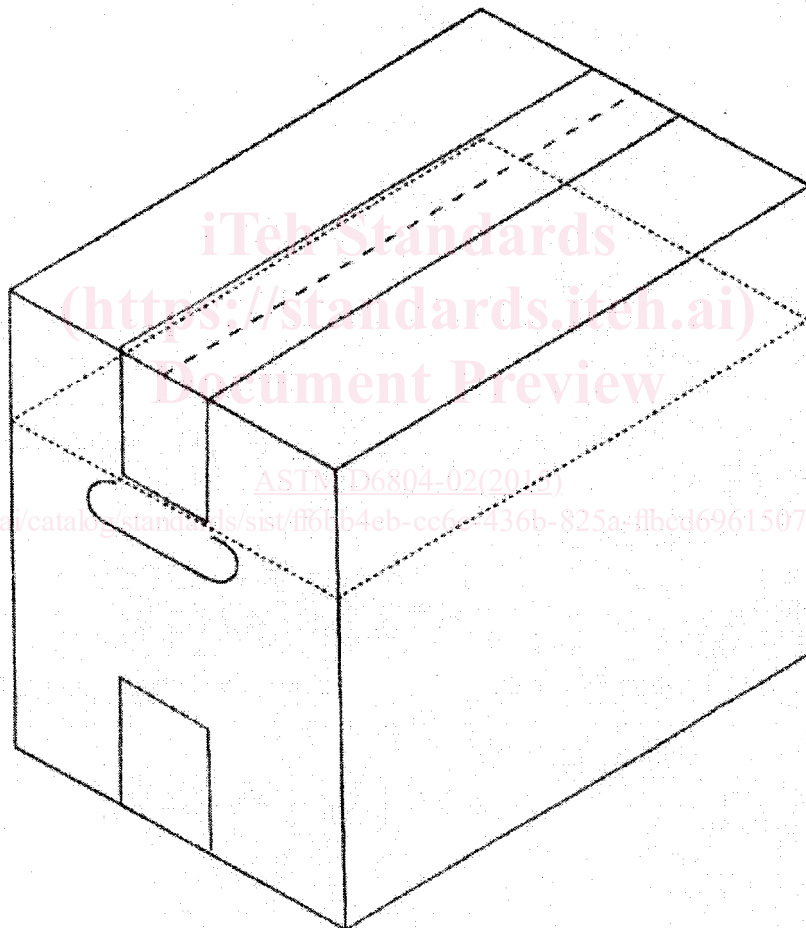

FIG. 5 RSC Style Box showing placement of Reinforcement Material around perimeter of box, just above Hand Hole

**APPENDIX****(Nonmandatory Information)****X1. EVALUATION OF PERFORMANCE OF HAND HOLES IN CORRUGATED BOXES****X1.1 Summary of Methods**

X1.1.1 *Method A, Jerk Test*—Uses free-fall drop test apparatus in conjunction with a support apparatus and grasping device(s), imparting a sudden sharp arrested motion (jerk) to the hand hole area of a corrugated box. A grasping device similar to that shown in [Fig. X1.1](#) provides contact with the hand hole.

X1.1.1.1 This method is applicable for testing both one- and two-hand lifting of boxes. It is not intended for horizontal pulling of the box (see Method B, Tensile Test).

X1.1.2 *Method B, Tensile Test*—Uses tensile testing machines having a constant free-running crosshead speed or constant extension rate to determine the maximum load carrying ability of the hand hole(s) in the tested box. Contact with the hand hole is provided by the same type of grasping device used for Method A, and the box is fixed to the stationary portion of the machine.

X1.1.2.1 With proper fixturing, this method is applicable to testing one- and two-hand lifting, and horizontal pulling of boxes.

**X1.2 Significance and Use**

X1.2.1 These test methods will assist in determining whether hand holes in corrugated boxes will perform to specific level(s) of handling force(s) expected in the distribution environment during manual handling. These forces can be static, that is, a box picked up slowly, or dynamic, a box picked up or moved with a jerking motion. These methods may be used to compare different types of hand hole/box construction, or to measure performance to a specified level.

X1.2.2 During testing, forces are applied in directions most frequently seen in normal manual handling. In addition to the normal direction of force (usually vertical), other directions could be diagonal (such as when lifting a box with one hand) and at 90° (such as when boxes are pulled by the hand hole rather than lifted).

**X1.3 Apparatus****X1.3.1 Grasping Device:**

X1.3.1.1 The grasping device shall be similar to that shown in [Fig. X1.1](#). The width should be modified to match the width of the straight portion of the hand hole, up to a maximum width of 4 in. Hand holes having a curved top edge may require special designs, to be determined by the user.

X1.3.1.2 For a vertical jerk or tensile test, two grasping devices are used, each connected to a spreader bar that supports the two devices at a distance such that the devices hang vertically when lightly engaging both hand holes (see [Fig. X1.2](#)).

X1.3.1.3 The user must be sure that the grasping devices, spreader bar, and connecting hardware are of sufficient strength to safely hold the load.

**X1.3.2 Method A, Jerk Test (see [Fig. X1.2](#)):**

X1.3.2.1 Drop Test Apparatus, with a platform or other feature which supports a corrugated box, such that the box may be released for free-fall from a specified height. Support apparatus for the grasping device must suspend the box at least 6 in. (150 mm) above the floor or test apparatus base. The support apparatus must secure the grasping device(s) so essentially no yielding or elastic stretch occurs when the box falls and its motion is arrested by the device(s). A chain or flexible steel cable suspended from a rigid support or overhead hoist may be used for this purpose.

X1.3.2.2 An elastic cord may be used to take up the slack in the chain or cable to make sure the grasping device(s) stays in the