



Designation: **C209 – 12 C209 – 15**

Standard Test Methods for Cellulosic Fiber Insulating Board¹

This standard is issued under the fixed designation C209; the number immediately following the designation indicates the year of original adoption or, in the case of revision, the year of last revision. A number in parentheses indicates the year of last reappraisal. A superscript epsilon (ϵ) indicates an editorial change since the last revision or reappraisal.

This standard has been approved for use by agencies of the U.S. Department of Defense.

1. Scope

1.1 These test methods cover those insulation products in specified Specification **C208**. The requirements for the products' physical properties are specified in Specification **C208**. The methods for the general insulation products' physical properties are given as follows:

	Section
Thickness	7
Size of Finished Board	8
Thermal Conductivity	9
Transverse Strength	10
Deflection at Specified Minimum Load	11
Tensile Strength Parallel to Surface	12
Tensile Strength Perpendicular to Surface	13
Water Absorption	14
Linear Expansion	15
Water Vapor Transmission	16
Flame Spread Index	17
Moisture Content and Density	18
Compressive Strength	19

1.2 Reference is provided to an established source for nomenclature and definitions.

1.3 *This standard does not purport to address all of the safety concerns, if any, associated with its use. It is the responsibility of the user of this standard to establish appropriate safety and health practices and determine the applicability of regulatory limitations prior to use.*

1.4 Several of the test methods contained in this document are referenced by material specifications other than cellulosic fiber insulating board. These include mineral fiber, perlite, polyisocyanurate, polystyrene and phenolic materials.

2. Referenced Documents

2.1 *ASTM Standards:*²

- C165 Test Method for Measuring Compressive Properties of Thermal Insulations
- C168 Terminology Relating to Thermal Insulation
- C177 Test Method for Steady-State Heat Flux Measurements and Thermal Transmission Properties by Means of the Guarded-Hot-Plate Apparatus
- C208 Specification for Cellulosic Fiber Insulating Board
- C518 Test Method for Steady-State Thermal Transmission Properties by Means of the Heat Flow Meter Apparatus
- C870 Practice for Conditioning of Thermal Insulating Materials
- C1045 Practice for Calculating Thermal Transmission Properties Under Steady-State Conditions
- C1114 Test Method for Steady-State Thermal Transmission Properties by Means of the Thin-Heater Apparatus
- D1037 Test Methods for Evaluating Properties of Wood-Base Fiber and Particle Panel Materials
- D1554 Terminology Relating to Wood-Base Fiber and Particle Panel Materials
- E84 Test Method for Surface Burning Characteristics of Building Materials
- E96/E96M Test Methods for Water Vapor Transmission of Materials

¹ These test methods are under the jurisdiction of ASTM Committee C16 on Thermal Insulation and are the direct responsibility of Subcommittee C16.32 on Mechanical Properties.

Current edition approved Oct. 15, 2012; Oct. 1, 2015. Published January 2013; October 2015. Originally approved in 1946. Last previous edition approved in 2007 as C209 – 07a; C209 – 12.¹ DOI: 10.1520/C0209-12.10.1520/C0209-15.

² For referenced ASTM standards, visit the ASTM website, www.astm.org, or contact ASTM Customer Service at service@astm.org. For *Annual Book of ASTM Standards* volume information, refer to the standard's Document Summary page on the ASTM website.

[E177 Practice for Use of the Terms Precision and Bias in ASTM Test Methods](#)

[E691 Practice for Conducting an Interlaboratory Study to Determine the Precision of a Test Method](#)

3. Terminology

3.1 *Definitions*—The definitions of terms used in these methods shall be in accordance with Definitions [D1554](#) and Terminology [C168](#).

3.2 *cellulosic fiber insulating board*—a fibrous-felted, homogeneous panel made from ligno-cellulosic fibers (usually wood) and having a density of less than 31 lb/ft³ (497 kg/m³) but more than 10 lb/ft³ (160 kg/m³).

3.2.1 Discussion—

Cellulosic fiber insulating board. It is characterized by an integral bond that is produced by interfelting of the fibers, but which has not been consolidated under heat and pressure as a separate stage in manufacture. Other materials may be added during manufacture to improve certain properties.

3.3 Definitions of Terms Specific to This Standard:

3.3.1 *board*—refers to the material as received.

3.3.2 *sample*—refers to the 36 by 48-in. (0.9 by 1.2-m) piece cut from a board.

3.3.3 *test specimen*—refers to the test piece cut from a sample unless otherwise specified in the test method.

3.3.4 *sorption*—a general term in physical chemistry used to describe the combined processes of:

~~(1) *absorption*—refers to the taking up of matter in bulk by other matter, for example, the penetration of substances into the bulk of another solid or liquid.~~

~~(1) *absorption*—refers to the taking up of matter in bulk by other matter, for example, the penetration of substances into the bulk of another solid or liquid.~~

~~(2) *adsorption*—refers to surface retention or adhesion of an extremely thin layer of molecules to the surfaces of solids or liquids with which they are in contact.~~

~~(2) *adsorption*—refers to surface retention or adhesion of an extremely thin layer of molecules to the surfaces of solids or liquids with which they are in contact.~~

4. Significance and Use

4.1 The test methods contained in this document are intended for cellulosic fiber insulating board as described in Specification [C208](#). These test methods examine mechanical, physical and thermal properties, properties related to water absorption and water vapor exposure, and flammability related properties. [ASTM C209-15](#)

4.2 The results of these tests ~~may be used~~ are suitable to describe the performance of insulating board and are also suitable for use in material specifications.

NOTE 1—Committee C-16 is in the process of splitting this document into discrete test methods categorized by the nature of the test methods.

5. Sampling

5.1 *Selection of Boards*—Refer to Specification [C208](#), Section 9 on Sampling.

5.2 *Size of Sample*—From each board a sample, 36 by 48 in. (0.9 by 1.2 m) shall be cut. When possible, the larger dimension of the sample shall be crosswise of the longer dimension of the board as it is usually obtained. When the individual boards are less than 36 by 48 in. (0.9 by 1.2 m) in size, enough material shall be taken to give the equivalent area.

6. Test Conditions

6.1 *Preconditioning*—Tests shall be made under prevailing atmospheric conditions except in the case of dispute. Tests then shall be made on specimens conditioned until equilibrium is obtained in accordance with Practice [C870](#).

7. Thickness

7.1 *Apparatus*—An instrument such as a dial gage capable of measuring a 36 by 48 in. (0.9 by 1.2 m) sample, on which the contacting surfaces are flat and have a minimum diameter of ½ in. (13 mm) shall be used. Pressure on the contacting surfaces shall not be greater than 1 psi (6.9 kPa) nor less than 0.25 psi (1.7 kPa), and the instrument shall read to an accuracy of 0.001 in. (0.03 mm).

7.2 *Procedure*—Measure the thickness at five points, near each corner and near the center, to an accuracy of ±0.001 in. (±0.02 mm). Take care that the sample is not deformed when the thickness measurements are taken.

7.3 *Calculation and Report*—Report the average of the five measurements as the average thickness of the sample. Report as the average thickness of the sample, the average thickness of the lot, report thickness tolerance, as follows:

$$\text{Thickness tolerance} = (h_1 - h_2)/h_1 \quad (1)$$

where:

h_1 = average thickness of lot, and

h_2 = average thickness of sample.

8. Size of Finished Board

8.1 *Procedure*—Obtain the average width of the finished board by measuring the width at each end and at the middle to an accuracy of $\pm 0.3\%$ or $\frac{1}{16}$ in. (2 mm), whichever is smaller, and averaging these readings. Obtain the average length of the finished board in a similar manner.

9. Thermal Conductivity

9.1 *Procedure*—Determine thermal conductivity in accordance with Test Method **C177**, or in accordance with Test Methods **C518**, **C1045** or **C1114**. Test two specimens from one sample from one board.

10. Transverse Strength

10.1 Apparatus:

10.1.1 *Testing Machine*—Any standard mechanical or hydraulic testing machine capable of applying and measuring the required load within an accuracy of $\pm 2\%$ ~~may be used~~ is suitable for use.

10.1.2 *Bearing Edges*—The bearing edges shall be rounded to a radius of $\frac{3}{8}$ in. (10 mm) to prevent injury to the specimen. The bearing edges shall be straight and shall maintain full contact with the specimen throughout the test.

10.2 *Test Specimen*—The specimen shall be 3 by 15 in. (76 by 381 mm) and conditioned in accordance with **6.1**. Three specimens from the long dimension of each sample from each board and three at right angles shall be tested. If the sample has a dimension less than 15 in. (381 mm), test only in that direction for which a 15 in. (381 mm) specimen can be obtained.

10.3 *Procedure*—Determine the transverse load by placing the specimen on horizontal bearing edges 12 in. (305 mm) apart and applying the load at midspan on a bearing parallel to the end supports, so that the head of the testing machines, through which the load is applied, moves at a rate of 6 ± 2 in./min (152 ± 51 mm/min) until failure occurs.

10.4 *Calculation and Report*—Report as the transverse load for specimen, the maximum load reached during the test. Report as the average transverse load in pounds-force (or Newtons) in each direction for a sample, the average of three specimens taken from that direction. Report as the total average transverse load in each direction, the average of all samples in that direction. Calculate modulus of rupture values in pounds-force per square inch (or megapascals) as follows:

$$MOR = 6P/t^2 \quad (2)$$

where:

MOR = Modulus of rupture, psi (MPa),

P = Transverse load, lbf (N), and

t = thickness, in. (mm).

10.5 *Precision and Bias*—See Section **20**.

11. Deflection at Specific Minimum Load

11.1 *Procedure*—Determine, to the nearest 0.01 ~~in.~~ mm, the deflection at the corner of each specimen subjected to the minimum transverse load, by means of a suitable measuring device such as a dial gage under the specimen, a steel rule alongside the specimen, or measurement of the crosshead movement.

11.2 *Calculation and Report*—Report as the average deflection in each direction for a sample, the average of three specimens taken from that direction. Report as the total average deflection in each direction, the average of all samples in that direction.

11.3 *Precision and Bias*—See Section **20**.

12. Tensile Strength Parallel to Surface

12.1 *Apparatus*—Any standard mechanical or hydraulic testing machine capable of applying and measuring the required load within an accuracy of $\pm 2\%$ ~~may be used~~ is suitable for use.

12.2 *Test Specimen*—Specimens shall be prepared in accordance with **Fig. 1**, and conditioned in accordance with **6.1**. Three specimens from the long direction of each sample from each board and three at right angles thereto shall be tested.

12.3 *Procedure*—Set the testing machine for a rate of separation of the jaws of $2 \pm \frac{1}{4}$ in./min (51 ± 6 mm/min). Clamp the specimens in the jaws at a minimum distance of 6 in. (152 mm) apart. Specimens breaking within $\frac{1}{2}$ in. (13 mm) of the jaws shall be disregarded. Measure the specimens, after breaking, for width and thickness at the break to the nearest 0.01 in. (0.3 mm).

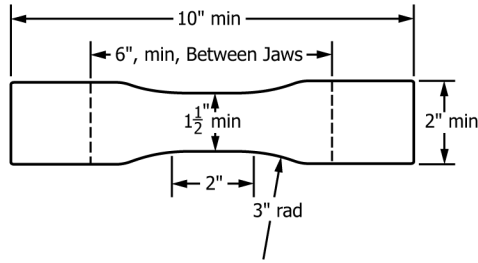

SI Equivalents

in.	mm	in.	mm
10	254	2	51
6	152	1 1/2	38
3	76		

FIG. 1 Specimen for Determination of Tensile Strength Parallel to Surface

12.4 *Calculation and Report*—Report as the average tensile strength in each direction for a sample, the average, in pounds-force per square inch (or kilopascals), of the three specimens taken from that direction. Report as the total average value in each direction, the average of all samples in that direction.

12.5 *Precision and Bias*—See Section 20.

13. Tensile Strength Perpendicular to Surface

13.1 *Apparatus*—The apparatus shall be as shown in Fig. 2 and shall consist of two blocks 2 by 2 by 1 1/4 in. (51 by 51 by 32 mm) supplied with hooks in the center as shown in Fig. 2. Any standard mechanical or hydraulic testing machine capable of applying and measuring the required load within an accuracy of ±2 % may be used.

13.2 *Test Specimens*—The specimen shall be cut to match the lateral dimensions of the test block in 13.1 and conditioned in accordance with 6.1. Two specimens shall be tested, one each from the sample from two boards.

13.3 *Procedure*—Cement the two surfaces of the specimens to the blocks with a suitable adhesive. After the adhesive has set a sufficient length of time, apply a load at the rate of 2 ± 1/4 in./min (51 ± 6 mm/min) at the hooks until separation within the block.

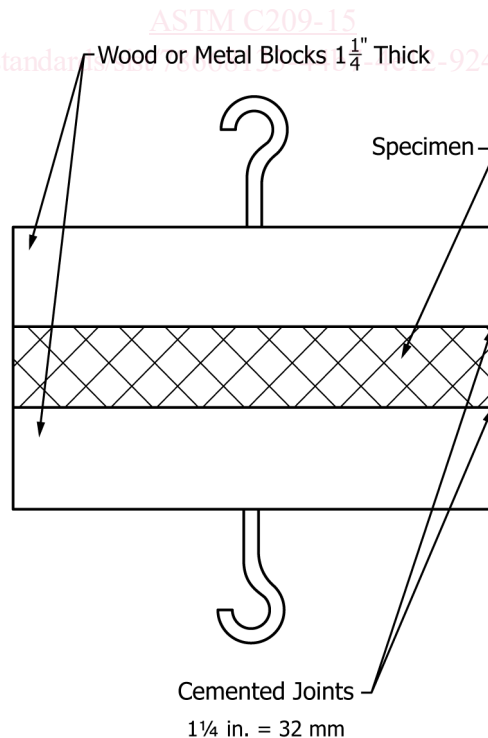

FIG. 2 Apparatus for Determination of Tensile Strength Perpendicular to Surface