



Standard Specification for Fiberglass (GRP) Pultruded Open-Weather Storm- and Guard-Square Handrails¹

This standard is issued under the fixed designation F 1092; the number immediately following the designation indicates the year of original adoption or, in the case of revision, the year of last revision. A number in parentheses indicates the year of last reapproval. A superscript epsilon (ϵ) indicates an editorial change since the last revision or reapproval.

^{e1} NOTE—Section 10 was added editorially in June 1994.

1. Scope

1.1 This specification provides the material requirements, construction, installation, and testing requirements for open-weather deck, storm-and-guard, fiberglass square rails. The handrail components are to be manufactured by the pultrusion process.

1.2 The values stated in inch-pound units are to be regarded as the standard. The SI units given in parentheses are for information purposes only and may be approximate.

1.3 The following safety hazards caveat pertains only to the test methods portion, Section 9, of this specification: *This standard does not purport to address all of the safety concerns, if any, associated with its use. It is the responsibility of the user of this standard to establish appropriate safety and health practices and determine the applicability of regulatory limitations prior to use.*

2. Referenced Documents

2.1 ASTM Standards:

- D 570 Test Method for Water Absorption of Plastics²
- D 638 Test Method for Tensile Properties of Plastics²
- D 695 Test Method for Compressive Properties of Rigid Plastics²
- D 790 Test Methods for Flexural Properties of Unreinforced and Reinforced Plastics and Electrical Insulating Materials²
- D 792 Test Methods for Specific Gravity (Relative Density) and Density of Plastics by Displacement²
- D 3846 Test Method for In-Plane Shear Strength of Reinforced Plastics³
- D 3917 Specification for Dimensional Tolerance of Thermosetting Glass-Reinforced Plastic Pultruded Shapes³
- E 84 Test Method for Surface Burning Characteristics of Building Materials⁴

¹ This specification is under the jurisdiction of ASTM Committee F25 on Shipbuilding and is the direct responsibility of Subcommittee F25.03 on Outfitting. Current edition approved Oct. 30, 1987. Published December 1987.

² Annual Book of ASTM Standards, Vol 08.01.

³ Annual Book of ASTM Standards, Vol 08.02.

⁴ Annual Book of ASTM Standards, Vol 04.07.

3. Terminology Definition

3.1 *pultrusion*—process of pulling fiberglass rovings (strands), mats, and other forms of reinforcements such as woven fiberglass through baths of thermosetting liquid resin, and then through a heated forming die (made of steel) to form a completed composite fiberglass structural shape.

3.2 *Discussion*—The heated die causes a chemical reaction to be initiated in the resin. The liquid resin molecules will cross-link and develop into a hardened plastic that is reinforced with the fiberglass.

4. Classification

4.1 Handrails and stanchions shall be fiberglass pultruded square tube available in the following two types:

4.1.1 *Type 1F*—Three course rails, for use along the exposed peripheries of freeboards, weather docks, and superstructure decks.

4.1.2 *Type 2F*—Two course rails, for use on bridges, platforms, walkways, and elsewhere as needed.

5. Ordering Information

5.1 Orders for materials under this specification shall include the following information:

5.1.1 Quantity (lineal feet of handrail).

5.1.2 Name of material (fiberglass pultruded square handrail).

5.1.3 Type (See 4.1).

5.1.4 Fiberglass coaming, if specified (lineal feet). (See 6.2.5).

5.1.5 Attachment method for rail stanchions (see 6.2.6).

5.1.6 ASTM designation and year of issue.

6. Materials and Manufacture

6.1 Materials:

6.1.1 The fiberglass (GRP) pultruded square tube shall be 2 by ¼ in. (51 by 6.4 mm) with the outside corner radius ⅜ in. (2.4 mm). A synthetic surface veil shall be the outermost layer of reinforcement covering the entire exterior surface. The resin used throughout the part shall be either a flame retardant isophthalic polyester or a flame retardant vinyl ester resin

containing an ultra-violet radiation (UV) inhibitor. The fiberglass pultruded square tube shall achieve a 25 or less rating in accordance with Test Method E 84. The exterior of the pultruded square tubing shall have a 1 mil (0.025 mm) minimum polyurethane protective coating for added ultraviolet protection. The fiberglass pultruded square tubing shall meet the properties specified in Table 1 and dimensional tolerances shall be in accordance with Specification D 3917.

6.1.2 Fiberglass sheet or solid fiberglass bar shall be used to fabricate the internal connectors for the square tube. The internal connectors will be 1½ by 1½ in. (38.1 by 38.1 mm) with length and angularity variable to meet the requirements of each connection. Angular connections shall be fabricated from fiberglass sheet bonded together using a bisphenol A/epichlorohydrin epoxy resin with an amine curing agent to give a minimum thickness of 1½ in. The angular connections will be fabricated to the proper dimension from the fiberglass sheets that have been bonded together. Fiberglass sheet used for angular connections shall meet the properties specified in Table 1. Fiberglass solid bar, 1½ by 1½ in., shall be used for the straight connections and shall meet the properties specified in Table 1.

6.1.3 Rivets shall be nickel copper or nonmetallic.

6.1.4 Bolts shall be ⅜ in. (9.5 mm) diameter, 316 stainless steel.

6.1.5 Adhesive used to bond internal connectors to fiberglass pultruded square tube shall be a bisphenol A/epichlorohydrin epoxy resin with an amine curing agent.

6.2 *Manufacture:*

6.2.1 There shall be a minimum clearance of 4 in. (101 mm) between handrail centerline and other structure except where a direct tie-in is desired.

6.2.2 Stanchions and standoffs are to be spaced on 5 ft (1.52 m) maximum centers.

6.2.3 All top rails are to be located 40 in. (1.0 m) above the deck (deck to top of square tube).

6.2.4 Handrail height for ladders shall be measured vertically from the nosing line.

6.2.5 Coaming constructed of fiberglass pultruded material may be specified and shall meet the properties specified in Table 1. Fiberglass coaming shall be 4 in. (101 mm) in vertical height from its top edge to the level of the deck. Fiberglass coaming shall be a corrugated or channel design with a minimum of ½ in. (12 mm) deep section or minimum ½ in. channel leg to develop added strength. It shall be securely fastened to the stanchion using nickel-copper rivets and with not more than ¼ in. (6.4 mm) clearance above floor level. The thickness shall be at least ⅜ in. (4.75 mm) with the overall depth not more than 1 in. (26 mm). See Fig. 1 for example.

6.2.6 Fiberglass square tube rail stanchions may be attached to the deck or structural supports as follows:

6.2.6.1 Attached to steel coaming (Fig. 2).

6.2.6.2 Inserted in pedestal/post mount (Fig. 3).

6.2.6.3 Attached to structural members (Fig. 4).

6.2.6.4 Attached to steel angle (Fig. 5).

7. Dimensions

7.1 *Dimensions for Type 1F*—Three course rails shall be in accordance with Fig. 6.

7.2 *Dimensions for Type 2F*—Two course rails shall be in accordance with Fig. 1.

8. Workmanship, Finish, and Appearance

8.1 All cut edges and holes shall be sealed with a compatible resin system containing a UV inhibitor.

8.2 All connections shall be made using a one piece solid internal connector (in accordance with 6.1.2) bonded to the interior of the square tube using an epoxy adhesive and riveted. The following types of connections are defined:

8.2.1 Corner connection (Fig. 7).

8.2.2 Splice (Fig. 8).

8.2.3 Midrail to stanchion (Fig. 9).

8.2.4 Top rail to stanchion (Fig. 10).

8.2.5 Stair handrail to stanchion (Fig. 11).

8.2.6 Stair rail to rail (Fig. 12).

8.3 All bolted connections shall have a one-piece solid internal connector (in accordance with 6.1.2) bonded to the interior of the square tube through which connector holes will be drilled. A minimum 1 in. (26 mm) length of the solid internal connector will be on each side of the drilled hole.

8.4 Additional solid internal connector pieces can be bonded with epoxy adhesive to the interior of the square tube as desired.

9. Test Methods

9.1 Test at least one end stanchion and one other stanchion of each platform or deck by application of a 300 lb (1334 N) load horizontally outboard at the top of the stanchion and perpendicular to the railings. Hold the load for 10 min. Test 20 % of all top railing sections on each platform or deck (minimum of one which shall be an end section if any) at the midpoint between stanchions by application of a 300 lb load horizontally outboard and perpendicular to the rail. Hold load for 10 min. After release of the loads, there shall be no permanent deformation or visible damage. Minor cracks in the adhesive at the joints are permissible. Seal any minor cracks in the adhesive following the procedure in 8.1.

10. Keywords

10.1 fiberglass rails; handrails; marine; open-weather deck; pultruded; ship; square rails; storm-and-guard

TABLE 1 Fiberglass Pultruded Material Properties

	Test Method	psi (MPa)
<i>Specifications for 2 × ¼ (51 × 6.4) Pultruded Fiberglass Square</i>		
<i>Tube and Coaming:</i>		
Ultimate tensile strength in longitudinal direction	D 638	30 000 (207), min
Ultimate compressive strength in longitudinal direction	D 695	30 000 (207), min
Ultimate flexural strength in longitudinal direction	D 790	30 000 (207), min
Ultimate shear strength in longitudinal direction	D 3846	5500 (38), min
Ultimate tensile strength in transverse direction	D 638	7000 (48), min
Ultimate compressive strength in transverse direction	D 695	15 000 (103), min
Ultimate flexural strength in transverse direction	D 790	10 000 (69), min
Ultimate shear strength in transverse direction	D 3846	5500 (38), min
Density (lb/in. ³ (kg/mm ³))	D 792	0.065 (0.00180), min
Water absorption (24-h immersion)	D 570	0.60 max, % by weight
<i>Specification for Pultruded Fiberglass Sheet:</i>		
Ultimate tensile strength in longitudinal direction	D 638	20 000 (138), min
Ultimate compressive strength in longitudinal direction	D 695	25 000 (172), min
Ultimate flexural strength in longitudinal direction	D 790	30 000 (207), min
Ultimate shear strength in longitudinal direction	D 3846	5500 (38), min
Ultimate tensile strength in transverse direction	D 638	10 000 (69), min
Ultimate compressive strength in transverse direction	D 695	15 000 (103), min
Ultimate flexural strength in transverse direction	D 790	13 000 (90), min
Ultimate shear strength in transverse direction	D 3846	5500 (38), min
Density (lb/in. ³ (kg/mm ³))	D 792	0.064 (0.00177), min
Water absorption (24-h immersion)	D 570	0.50 max, % by weight
<i>Specifications for Pultruded 1½ × 1½ in. (38.1 × 38.1 mm) Solid Fiberglass Bar:</i>		
Ultimate tensile strength in longitudinal direction	D 638	100 000 (689), min
Ultimate compressive strength in longitudinal direction	D 695	60 000 (414), min
Ultimate flexural strength in longitudinal direction	D 790	100 000 (689), min
Density (lb/in. ³ (kg/mm ³))	D 792	0.074 (0.00205), min
Water absorption (24-h immersion)	D 570	0.25 max, % by weight

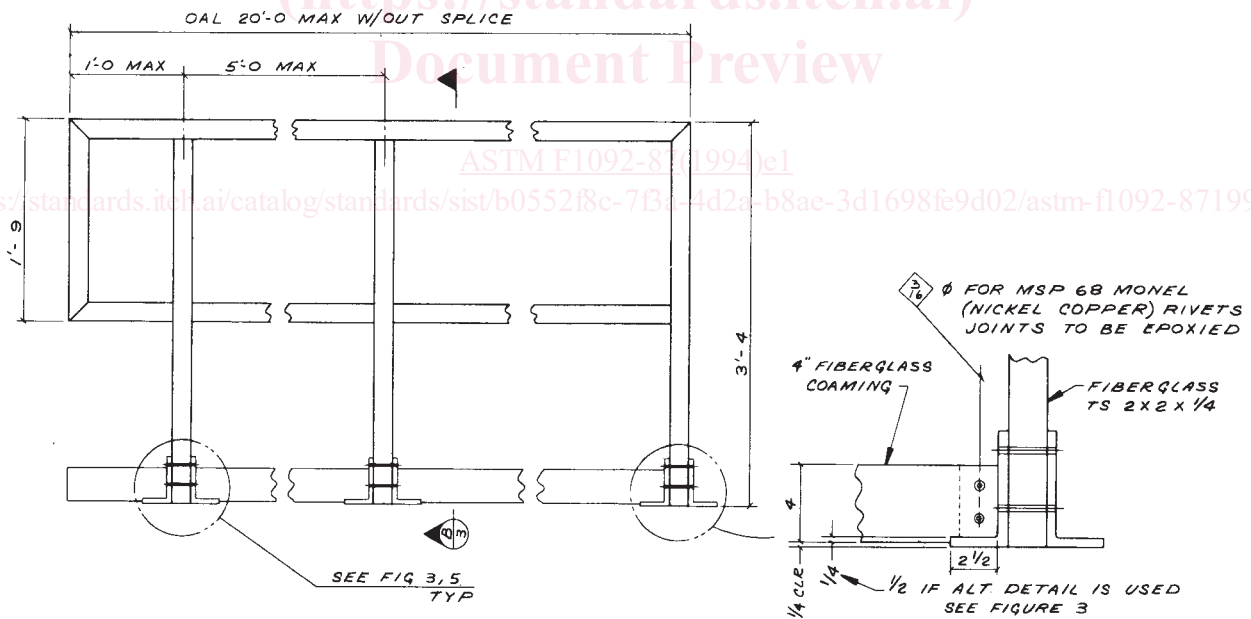

FIG. 1 Fiberglass Coaming

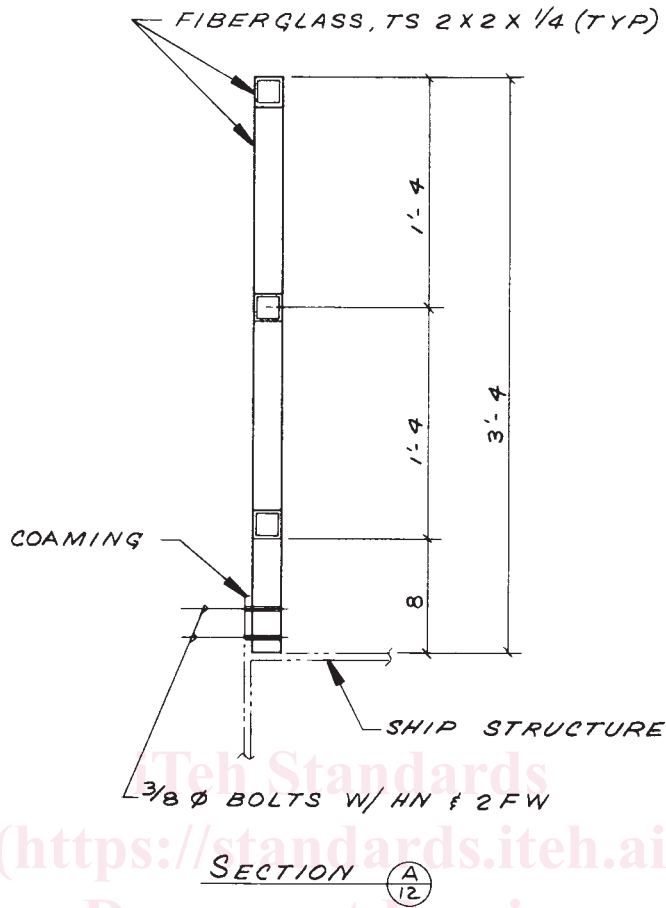
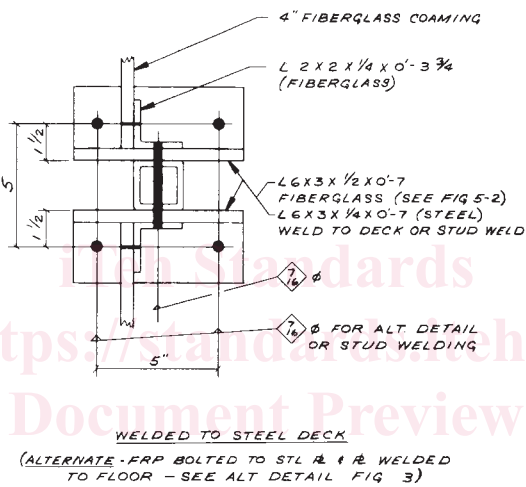
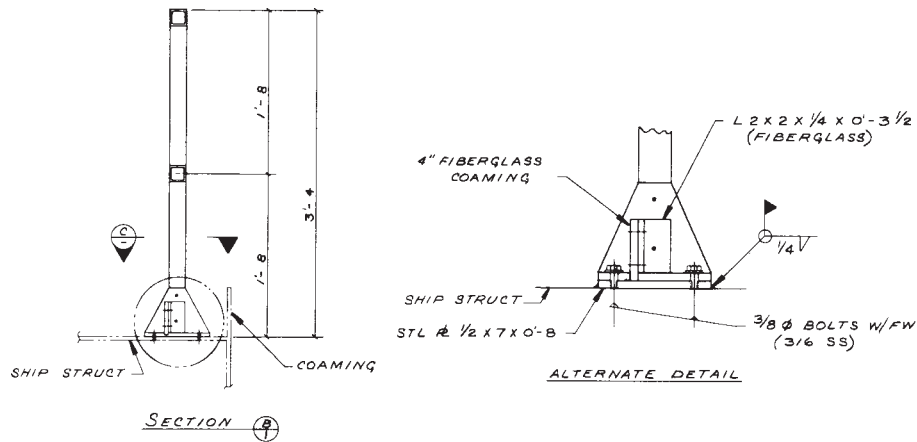

FIG. 2 Steel Coaming

ASTM F1092-87(1994)e1

<https://standards.iteh.ai/catalog/standards/sist/b0552f8c-7f3a-4d2a-b8ac-3d1698fe9d02/astm-f1092-871994e1>



NOTE 1—All joints to be epoxied and bolted or riveted.

FIG. 3 Pedestal/Post Mount

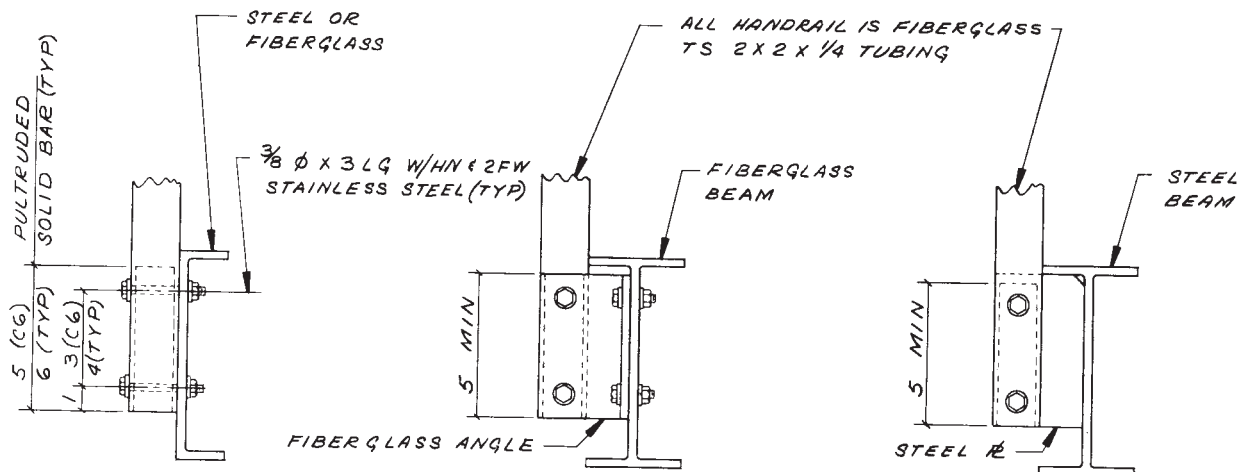

FIG. 4 Handrail Posts—Structural Members

L6X3X 1/4 X 0'-7 STEEL
ANGLE, WELDED OR
STUD WELDED TO
DECK

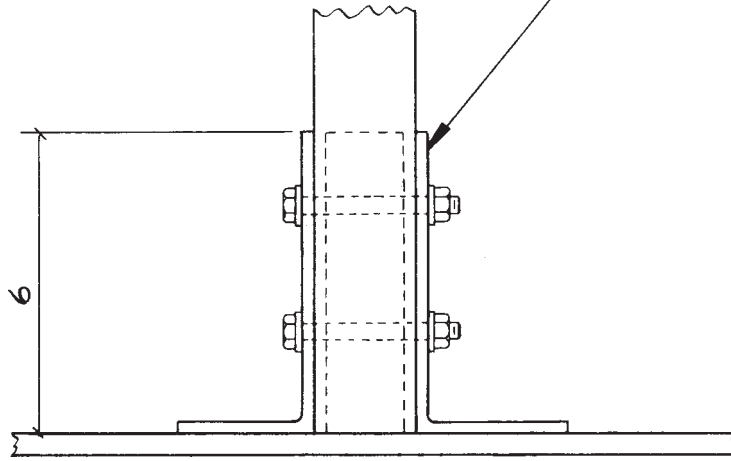

FIG. 5 Handrail Post Anchored to Steel Deck

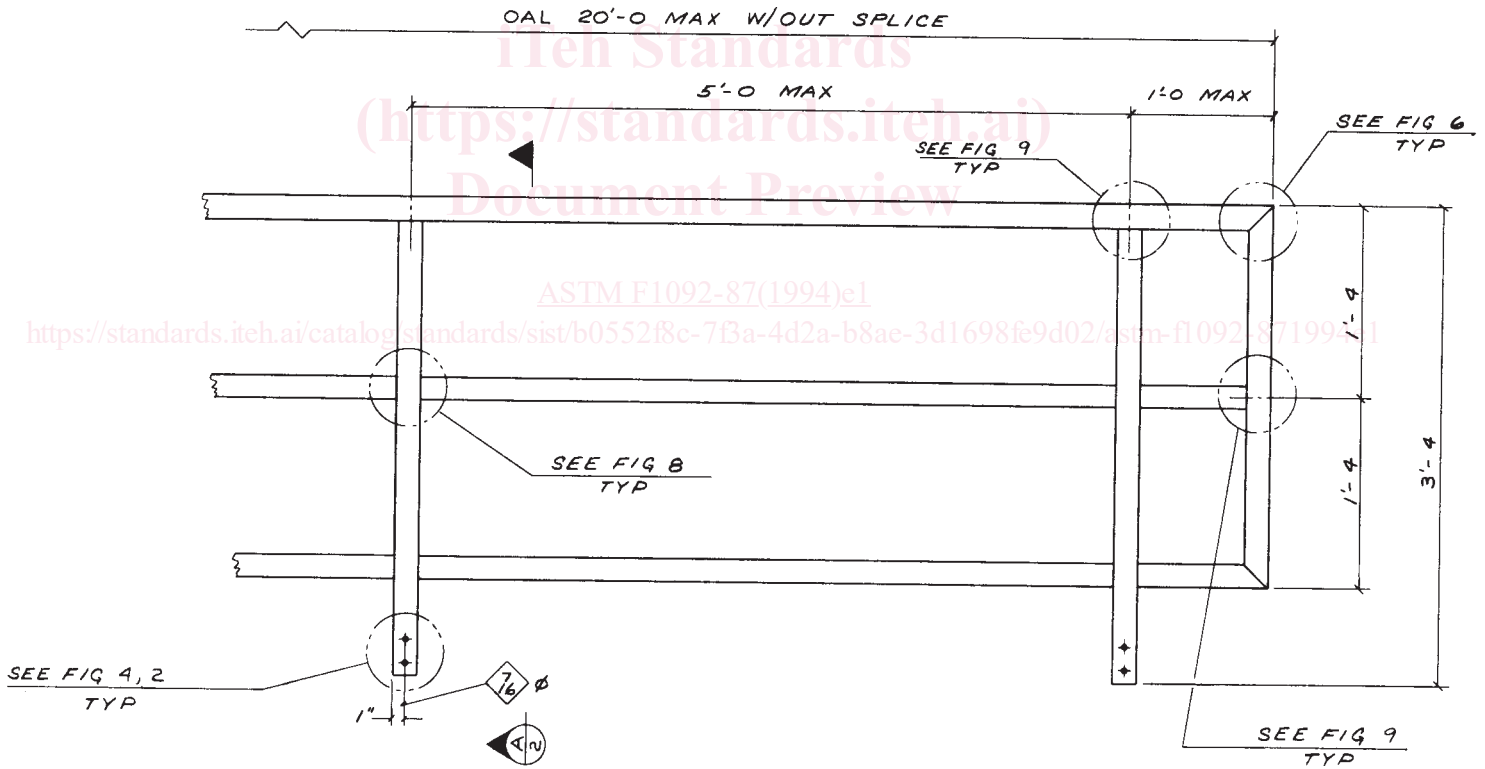

FIG. 6 Three Course Rail