



Designation: F 1094 – 87 (Reapproved 1999)

Standard Test Methods for Microbiological Monitoring of Water Used for Processing Electron and Microelectronic Devices by Direct Pressure Tap Sampling Valve and by the Presterilized Plastic Bag Method¹

This standard is issued under the fixed designation F 1094; the number immediately following the designation indicates the year of original adoption or, in the case of revision, the year of last revision. A number in parentheses indicates the year of last reapproval. A superscript epsilon (ϵ) indicates an editorial change since the last revision or reapproval.

1. Scope

1.1 These test methods cover sampling and analysis of high purity water from water purification systems and water transmission systems by the direct sampling tap and filtration of the sample collected in the bag. These test methods cover both the sampling of water lines and the subsequent microbiological analysis of the sample by the culture technique. The microorganisms recovered from the water samples and counted on the filters include both aerobes and facultative anaerobes.

1.2 Three methods are described as follows:

Test Method A—Sample Tap—Direct Filtration
Test Method B—Presterilized Plastic Bag Technique
Test Method B2 —Dip Strip Technique²/Presterilized Plastic Bag

Sections
6 to 8
9 to 12

1.3 *This standard does not purport to address all of the safety concerns, if any, associated with its use. It is the responsibility of the user of this standard to establish appropriate safety and health practices and determine the applicability of regulatory limitations prior to use².*

2. Referenced Documents

2.1 ASTM Standards:

- D 1129 Terminology Relating to Water³
- D 1193 Specification for Reagent Water³
- D 3370 Practices for Sampling Water³
- F 60 Test Methods for Detection and Estimation of Microbiological Contaminants in Water Used for Processing Electron and Microelectronic Devices⁴
- F 488 Test Method for On-Site Screening Heterotrophic Bacteria in Water⁵

¹ These test methods are under the jurisdiction of ASTM Committee F-1 on Electronics and are the direct responsibility of Subcommittee F01.10 on Processing Environments.

Current edition approved Oct. 30, 1987. Published December 1987.

² The dip strip (Total Count Tester or SPC Sampler) method is permissible for waters containing >10 microorganisms per millilitre.

³ *Annual Book of ASTM Standards*, Vol 11.01.

⁴ Discontinued; see *1991 Annual Book of ASTM Standards*, Vol 10.05.

⁵ *Annual Book of ASTM Standards*, Vol 11.02.

3. Terminology

3.1 Definitions:

3.1.1 *total bacteria count*—number of viable heterotrophic bacteria capable of growing under test conditions specified.

3.1.1.1 *Discussion*—Total bacteria count is the general term for heterotrophic plate count, now commonly used. Heterotrophic bacteria are those microorganisms that cannot use CO₂ for food. They require more complex organic compounds for use as growth nutrients. The majority of bacteria fall into this major grouping.

3.1.2 For definition of other terms used in this test method, refer to Terminology D 1129.

3.2 Definitions of Terms Specific to This Standard:

3.2.1 *presterilized plastic bag*—a commercial presterilized plastic bag of 200-mL capacity (or as appropriate to larger sample sizes) to hold sample water. The bag should have integral fold over tabs to allow for resealing.

3.2.2 *bacteriological monitor*—a commercial presterilized plastic filter holder containing a 0.45- μ m membrane filter. (No other filter pore size should be used.)

NOTE 1—If a larger pore size filter is used, organisms may pass through the filter; a smaller pore size filter does not wick up sufficient growth media, hence the level of recovery will be less than that of the 0.45- μ m filter.

3.2.3 *total count tester*—a paddle shaped plastic filter assembly containing a 0.45- μ m membrane filter and dehydrated nutrient pad.

4. Summary of Test Method

4.1 *Test Method A—Sample Tap—Direct Filtration*—A sampling valve as or similar to that shown in Fig. 1 is installed in a pressurized line. The valve illustrated has a self closure and a male luer outlet fitting. This valve design minimized the chance of extraneous contamination. Any valve used for sampling should be constructed in a manner to reduce or prevent the retention of bacteria within its internal surfaces, and should be easily sanitized. The bacterial monitor is connected to either the luer outlet of the illustrated sampling valve, or in a suitable manner to an equivalent valve. The water

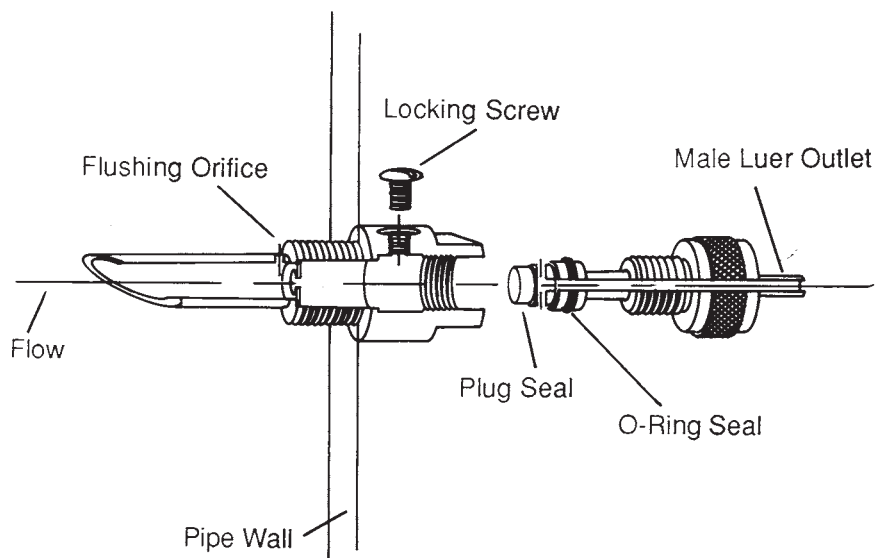

FIG. 1 Sampling Valve in Wall of Pressurized Line

sample is passed directly through the monitor, and the effluent volume is measured after this filtration. Test Methods F 60 are then employed for bacteriological examination of the sample.

4.2 *Test Method B—Presterilized Plastic Bag*—The sampling valve is installed as in Test Method A, then flushed clean prior to taking the samples. The water sample is directly flowed into a presterilized, precalibrated plastic disposable bag. After sampling, the plastic bag is sealed and stored briefly prior to bacteriological analysis of the sample. The sample may be stored at room temperature if analyzed within 2 h, otherwise, it should be stored from 4 to 10°C and analyzed within 6 h.

4.2.1 Sample analysis is conducted by either Test Methods F 60 or Test Method F 488 for bacterial content of the water.

5. Significance and Use

5.1 These test methods provide a field technique for the bacteriological analysis of electronic process waters. The sampling of these waters and subsequent bacteriological analysis may be critical to electronic product yields. Bacteria can be the prime source of harmful contamination which can significantly reduce the yield of satisfactory microelectronic device production.

5.2 The test methods described here may be used both to monitor the bacteriological quality of water used in microelectronic product processing, and to locate the source of bacterial contamination in a water purification system.

5.3 These test methods are simple field methods, combining sampling and bacteriological analysis techniques that do not require bacteriological laboratory facilities.

5.4 The test methods described employ culture techniques for bacteriological analysis. The user should be aware that such techniques cannot provide a complete count of the total viable bacteria present, since clumps and clusters of bacteria will appear as one single colony when cultured, and since some viable bacteria will not grow under the test conditions used. However, a meaningful comparative bacteria count will be achieved by this method if the culturing of the sample is always done at the same temperature, and for the same period of time.

The temperature of incubation should always be at $28 \pm 2^\circ\text{C}$, and the period of incubation should be 48 h (or 72 h if time permits). The period of incubation and temperature should be the same for all comparative studies.

TEST METHOD A—DIRECT SAMPLE TAP

6. Apparatus

6.1 *Sampling Tap*,⁶ see Fig. 1.

6.2 *Bacteriological Monitor*⁷ with 0.45- μm membrane filter.

6.3 *Sanitarians Kit*,⁷ consisting of metal syringe, special two way valve, and stainless steel graduated cup.

6.4 *Forceps*⁷ with blunt stainless, unserrated tips.

6.5 *Incubator*, capable of holding temperature within $\pm 1^\circ\text{C}$ in a range from 27 to 40°C .

6.6 *Illuminator*, 15 to 30-W incandescent or 8 to 10-W fluorescent are generally acceptable. If incandescent light is concentrated through or by a magnifying lens, a lower wattage may suffice.

6.7 *Magnifier*, 5 to 15 \times for counting colonies. An illuminator hand magnifier or a stereoscopic (dissection-type) microscope are satisfactory.

6.8 *Hypodermic Needle*, No. 18, 2-in. blunt nose with plastic syringe.

7. Reagents and Materials

7.1 *Isopropyl alcohol*, 70 to 90 %, or 3 to 6 % semi-standard or reagent grade, hydrogen peroxide solution.

⁶ The sole source of supply of valves, YY2004000, and YY20E4010 (catalogue number), known to the committee at this time is Millipore Corp., Bedford, MA. If you are aware of alternative suppliers, please provide this information to ASTM Headquarters. Your comments will receive careful consideration at a meeting of the responsible technical committee,¹ which you may attend.

⁷ The sole source of supply of these products known to the committee at this time is Millipore Corp., Bedford, MA. If you are aware of alternative suppliers, please provide this information to ASTM Headquarters. Your comments will receive careful consideration at a meeting of the responsible technical committee,¹ which you may attend.