



Designation: D6265 – 15

# Standard Practice for Separation of Contaminants in Polymers Using an Extruder Filter Test<sup>1</sup>

This standard is issued under the fixed designation D6265; the number immediately following the designation indicates the year of original adoption or, in the case of revision, the year of last revision. A number in parentheses indicates the year of last reapproval. A superscript epsilon ( $\epsilon$ ) indicates an editorial change since the last revision or reapproval.

## 1. Scope\*

1.1 This practice covers a means to separate the unmolten particles, gels, and impurities contaminating a polymer sample. The procedure may be used to remove gels and incompatible materials that may cause imperfections in the final extruded product. Under pressure, most gels will break up or deform and pass through a wire mesh filter, however high molecular weight gels may not break up or deform.

1.2 Materials isolated on a wire mesh filter can be identified by spectroscopic or other analytical means.

NOTE 1—Although not presented as a quantitative method, the procedure presented in this practice may be used to provide quantitative results at the discretion of the user. The user assumes the responsibility to verify the reproducibility of quantitative results. Detection limit depends on the mesh size of the filter screen, but the procedure is generally applicable to the separation of immiscible contaminants present at concentrations greater than 0.1 %.

1.3 The values stated in SI units are to be regarded as standard.

1.4 *This standard does not purport to address the safety concerns, if any, associated with its use. It is the responsibility of the user of this standard to establish appropriate safety and health practices and determine the applicability of regulatory limitations prior to use.* For specific hazards statements, see Section 8.

NOTE 2—There is no known ISO equivalent to this standard.

## 2. Referenced Documents

2.1 *ASTM Standards:*<sup>2</sup>

D1238 Test Method for Melt Flow Rates of Thermoplastics by Extrusion Plastometer

D1600 Terminology for Abbreviated Terms Relating to Plastics

<sup>1</sup> This test method is under the jurisdiction of ASTM Committee D20 on Plastics and is the direct responsibility of Subcommittee D20.95 on Recycled Plastics.

Current edition approved Oct. 1, 2015. Published October 2015. Originally approved in 1998. Last previous edition approved in 2009 as D6265 - 09. DOI: 10.1520/D6265-15.

<sup>2</sup> For referenced ASTM standards, visit the ASTM website, www.astm.org, or contact ASTM Customer Service at service@astm.org. For *Annual Book of ASTM Standards* volume information, refer to the standard's Document Summary page on the ASTM website.

D7209 Guide for Waste Reduction, Resource Recovery, and Use of Recycled Polymeric Materials and Products (Withdrawn 2015)<sup>3</sup>

IEEE/ASTM SI-10 Practice for Use of the International System of Units (SI) (the Modernized Metric System)

## 3. Terminology

3.1 The terminology used in this practice is in accordance with Terminology D1600 and Guide D7209. Units and symbols are in accordance with Practice IEEE/ASTM SI-10.

## 4. Summary of Practice

4.1 This practice determines the relative contamination level that can cause undesirable imperfections in the extruded product due to contaminants and gels. Although this practice is not designed to provide an absolute measurement of contamination level, using appropriate criteria, the rate of this pressure rise can be correlated to the relative contamination level.

## 5. Significance and Use

5.1 Problems with extrusion and subsequent processing of the material are caused, in part, by the presence of paper, metal, gels, incompatible polymers, or other extraneous contamination found in polymers.

## 6. Apparatus

6.1 *Extruder*, designed to deliver a continuous supply of molten resin to a filter at a uniform rate with good temperature control. Extruders with 18 to 64-mm diameters have been found to be satisfactory.

6.1.1 *Internal Rod Die*, to fix the filter area. Fig. 1 shows a typical 6.4 mm diameter die that gives a filter area of 12.45 mm<sup>2</sup>.

6.1.2 *Breaker Plate or Screen Holder*—A typical configuration is shown in Fig. 2.

6.1.3 *Pressure Transducer*, installed in-line before the screen pack and connected to digital readout.

6.1.4 *Melt Thermocouple*, installed before or after the screen pack.

<sup>3</sup> The last approved version of this historical standard is referenced on www.astm.org.

\*A Summary of Changes section appears at the end of this standard

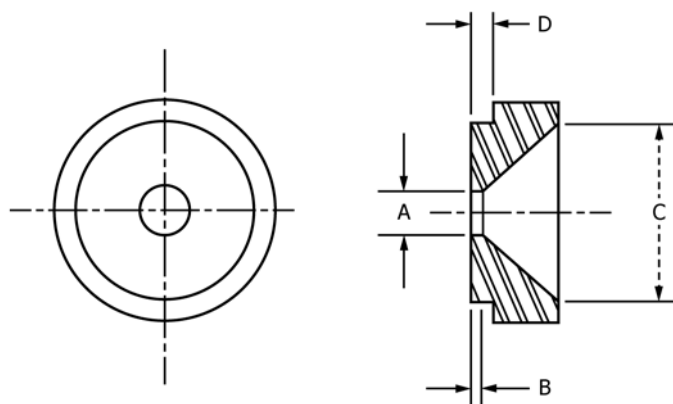

NOTE 1—A = 0.250 in.,  
 B = 0.0625 in.,  
 C = same diameter as extruder barrel, and  
 D = dimension that when added to the total thickness of the screen pack shall exceed the depth of the screen-retaining recess of the breaker plate to permit compression of the screens.

FIG. 1 Schematic Showing the Internal Sizing of the (Rod) Die

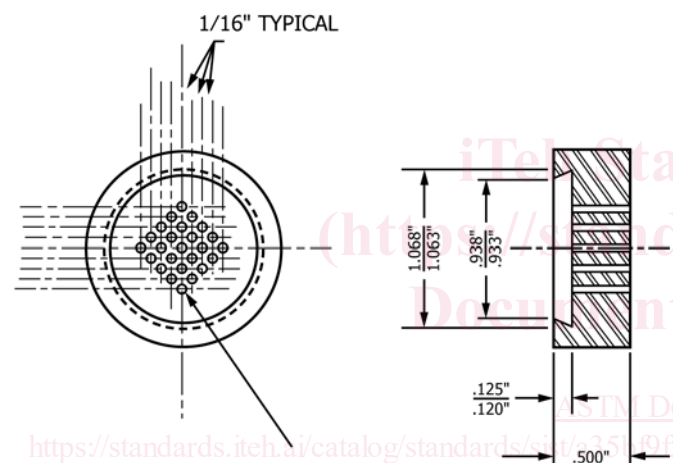

NOTE 1—Drill 25 holes; use #60 drill.

FIG. 2 Schematic of the Breaker Plate

6.1.5 High Pressure Alarm and Rupture Disk.

6.1.6 Split Clamp, to permit ready access to the screens, sizing die, and breaker plate.

6.1.7 Swing Gate, to support the split clamp (6.1.6) during screen changes.

NOTE 3—Although desirable, a swing gate is not always available on small extruders.

6.2 Screens, The screen diameter is equal to the barrel diameter. Screen sizes of 60 mesh (0.251-mm opening), 100 mesh (0.152-mm opening), 200 mesh (0.076-mm opening), or 325 mesh (0.045-mm opening) have been found to be satisfactory.

NOTE 4—If the rate of pressure increase is impractical due to extremes in the contaminant level or size, screens with alternative mesh sizes can be used.

6.3 Balance, capable of weighing with accuracy of  $\pm 0.1$  kg.

6.4 Torque Wrench, with ratchet drive attachment.

6.5 Thermally Insulated Gloves.

6.6 Spatulas and Scrapers, brass, assorted sizes for removing molten polymer from equipment.

7. Materials

7.1 Virgin Polymer, free of gels and contaminants, for purging the extruder equipment.

8. Hazards

8.1 Hot polymer can cause serious burns. Do not stand in front of the extruder because air bubbles, excessive temperature or pressure causes hot polymer to be expelled from the extruder die.

8.2 Wear thermally insulated gloves when handling hot polymer or working directly with the heated areas of the extruder.

9. Procedure

9.1 Turn on the power to the extruder and turn on the feed throat cooling water.

9.2 Set extruder temperature controllers to maintain the barrel at the appropriate temperature for the polymer (see Table 1).

9.3 Wait a minimum of 30 min after achieving extruder temperature before starting the extruder.

9.4 Insert a new screen pack using 60 (0.251 mm opening)-100 (0.152 mm opening) -60 mesh screens plus the backing screens for the extruder purge.

NOTE 5—The screen pack must have sufficient depth to prevent the breaker plate from fully contacting the rod die. This helps keep the screens firmly in place, insures the correct surface area of filter screw is actually used during the test, and simplifies disassembly.

9.5 Close the split clamp and tighten to 6.9 kg-m (50 ft-lb) using a torque wrench (this and other requirements may vary depending on the extruder model).

NOTE 6—Allow the breaker plate and rod die to heat up for an additional 5 min to melt any residual solidified polymer before starting the extruder.

9.6 Charge the hopper with 14 kg virgin polymer and start the extruder.

9.7 Adjust the screw speed to the desired setting and purge the system with virgin polymer.

9.7.1 For startup after more than 4 hours of non-use, purge 20 min at 10 to 20 rpm followed by 5 to 8 min at 100 rpm.

TABLE 1 Suggested Extruder Temperatures

Polymer	Extruder Temperature, °C
Acetals	190
Acrylics	230
Nylon	275
Polycarbonate	300
Polyethylene	200
Poly(ethylene terephthalate)	280
Polypropylene	230
Polystyrene	200
Poly(vinyl acetal)	150
Styrene-acrylonitrile	225