



Standard Test Method for Litter-Cleaning Effectiveness of Vacuum Cleaners¹

This standard is issued under the fixed designation F2609; the number immediately following the designation indicates the year of original adoption or, in the case of revision, the year of last revision. A number in parentheses indicates the year of last reapproval. A superscript epsilon (ϵ) indicates an editorial change since the last revision or reapproval.

1. Scope

1.1 This test method covers a laboratory test for determining the relative carpet litter-cleaning effectiveness of household vacuum cleaners when tested under standard conditions.

1.2 This test method is applicable to household types of upright, canister, combination, and stick vacuum cleaners intended for cleaning carpeted floors as a primary or secondary function.

1.3 This test method applies only to the cleaning of litter from carpet, not the removal of embedded dirt. Litter is defined as material that typically clings to the surface of the carpet, such as pet or human hair, thread, and so forth.

1.4 The values stated in inch-pound units are to be regarded as standard. The values given in parentheses are mathematical conversions to SI units that are provided for information only and are not considered standard.

1.5 *This standard does not purport to address all of the safety concerns, if any, associated with its use. It is the responsibility of the user of this standard to establish appropriate safety and health practices and determine the applicability of regulatory limitations prior to use.*

2. Referenced Documents

2.1 ASTM Standards:²

[E177 Practice for Use of the Terms Precision and Bias in ASTM Test Methods](#)

[F555 Test Method for Motor Life Evaluation of an Upright Vacuum Cleaner](#)

[F608 Test Method for Evaluation of Carpet Embedded Dirt Removal Effectiveness of Household/Commercial Vacuum Cleaners](#)

[F655 Specification for Test Carpets and Pads for Vacuum Cleaner Testing](#)

[F884 Test Method for Motor Life Evaluation of a Built-In \(Central Vacuum\) Vacuum Cleaner](#)

[F922 Test Method for Motor Life Evaluation of an Electric Motorized Nozzle](#)

[F1038 Test Method for Motor Life Evaluation of a Canister, Hand-held, Stick, and Utility Type Vacuum Cleaner Without a](#)

[Driven Agitator](#)

[F1334 Test Method for Determining A-Weighted Sound Power Level of Vacuum Cleaners](#)

[F1409 Test Method for Straight Line Movement of Vacuum Cleaners While Cleaning Carpets](#)

3. Significance and Use

3.1 This test method will provide an indication of the effectiveness of the vacuum cleaner in removing litter from carpet. No data exist to determine if the cleaning effectiveness in the laboratory will be the same as in home cleaning; however, in most cases, a vacuum cleaner that cleans well in the laboratory will clean well in a home.

3.2 To provide a uniform basis for measuring the performance described in 1.1, standardized test carpet and standardized test litter are used.

4. Apparatus

4.1 *LED Timer Bar*, or other type of equipment capable of establishing the specified rate of movement of the cleaner.

4.2 *Voltmeter*, to measure input voltage to the cleaner and provide measurements accurate to within $\pm 1\%$.

¹ This test method is under the jurisdiction of ASTM Committee F11 on Vacuum Cleaners and is the direct responsibility of Subcommittee F11.21 on Cleanability. Current edition approved Nov. 1, 2011; Nov. 1, 2015. Published January 2012; November 2015. Originally approved in 2007. Last previous edition approved in 2007 as F2609 – 07; F2609 – 11. DOI: 10.1520/F2609-11.10.1520/F2609-11R15.

² For referenced ASTM standards, visit the ASTM website, www.astm.org, or contact ASTM Customer Service at service@astm.org. For *Annual Book of ASTM Standards* volume information, refer to the standard's Document Summary page on the ASTM website.

4.3 *Voltage-Regulator System*, to control the input voltage to the cleaner. The regulator shall be capable of maintaining $120 \pm 1\%$ V root mean square (RMS), 60 Hz, with a waveform that is essentially sinusoidal with 3 % maximum harmonic distortion for the duration of the test.

4.4 *Test Carpets*, Wilton Wool; specification and source to be added.

4.5 *Test Padding*, Sponge rubber type of waffle construction as described in Specification F655.

4.6 *Psychrometer*, for measuring temperature and humidity.

4.7 *Rake*, for lightly embedding the litter into the test carpet. See Fig. 1 and Fig. 2.

4.8 *Supporting Surface*—A flat surface consisting of a piece of 3/4-in. (19-mm) thick exterior grade plywood with the “A” surface upward to support the test carpet and pad. The test carpet and pad may be fastened to the supporting surface, but only the four corners by any acceptable means.

4.9 *Test Area Template*—Cardboard or plastic sheet or equivalent with a 7- by 7-in. (178- by 178-mm) square opening. The opening defines the litter area and is to be centered within the 18-in. (457-mm) long cleaning stroke.

5. Reagents and Materials

5.1 *Test Litter*—Uncarded cut viscose rayon tow, 1.5 denier, 3/4-in. (19-mm) length, SN TN-79, unbleached, hard finish.

6. Sampling

6.1 A minimum of three units of the same model vacuum cleaner selected at random in accordance with good statistical practice shall constitute the population sample.

6.2 To determine the best estimate of cleaning ability for the population of the vacuum cleaner model being tested, the arithmetic mean of the cleaning ability rating of the sample from the population shall be established by testing it to a 90 % confidence level within $\pm 5\%$ of the mean value of the cleaning ability rating.

7. Conditioning

7.1 *Test Room*—Maintain the test room in which all conditioning and vacuum cleaner testing is done at $70 \pm 5^\circ\text{F}$ ($21 \pm 3^\circ\text{C}$) and 45 to 55 % relative humidity.

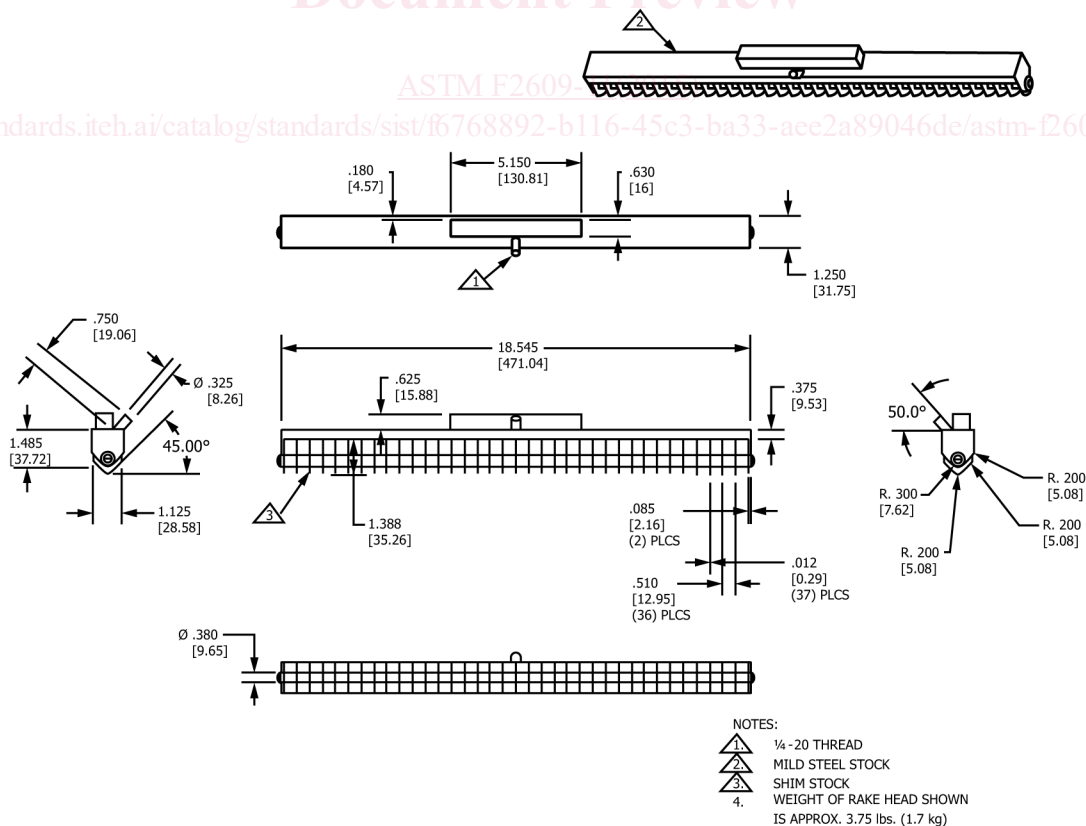
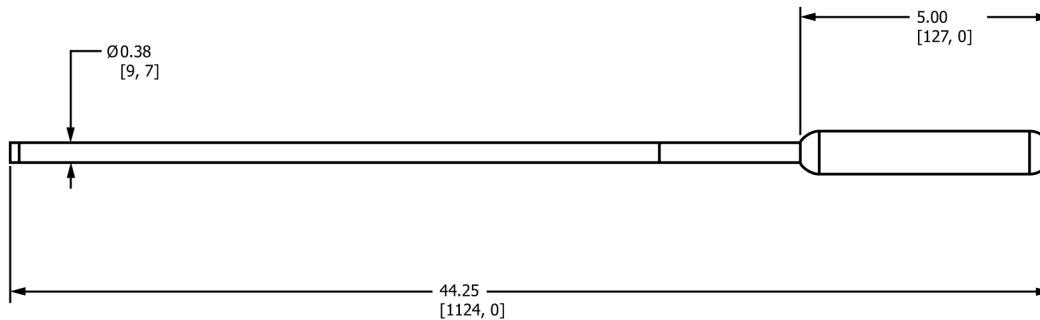

FIG. 1 Rake Head

NOTES:

1. HANDLE CAN BE SEGMENTED.
2. TOTAL HANDLE WEIGHT APPROX. 1.4 lbs> (.63 kg)

FIG. 2 Rake Handle

7.2 All components involved in the test shall remain and be exposed in the controlled environment for at least 16 h before the start of the test.

8. Procedure

8.1 Preparation of Test Vacuum Cleaners:

8.1.1 *New Test Vacuum Cleaners*—Run the vacuum cleaner in at rated voltage $\pm 1\%$ and rated frequency with filters in place.

8.1.1.1 *Preconditioning a Rotating Agitator-Type Vacuum Cleaner*—In a stationary position, operate the vacuum cleaner for 1 h with the agitator bristles not engaged on any surface.

8.1.1.2 *Preconditioning a Straight-Air-Type Vacuum Cleaner*—Operate the vacuum cleaner for 1 h with a wide-open inlet.

8.1.2 *Test Vacuum Cleaner Settings*—Tests shall be conducted using the same settings (nozzle, motor speed, suction regulator, and so forth) for the specific carpet as used for straight line movement (Test Method F1409), sound power (Test Method F1334), cleaning (Test Method F608), and motor life evaluation (Test Methods F555, F884, F922, and F1038).

8.1.3 Before each test run (cleaning of one square litter area), thoroughly remove excess rayon tow from the underside of the nozzle and brush area. For vacuum cleaners using disposable bags, use a clean bag for each test series (six test runs). For vacuum cleaners using nondisposable receptacles, empty after each test series (six test runs) and clean the receptacle until all traces of rayon tow are removed.

8.1.4 Mark the litter area on the test carpet or use the template.

8.1.5 To spread the rayon tow, start with a ball approximately 3 in. (8 cm) in diameter dabbing it lightly (do not rub in) and randomly over the prescribed area using a vertical motion of the hand. Any concentrated excess material shall be removed. All six test areas may be prepared at the same time, spaced evenly over the test carpet (see Figs. 3-6). Ensure the spacing between litter areas can accommodate the 18 in. (46 cm) stroke with the 7 in. (18 cm) litter area centered within it.

8.1.6 Embed the rayon tow into the test carpet by pulling the rake once over the litter area in the direction of carpet lay followed by pulling the rake once across the carpet perpendicular to the direction of carpet lay. Do not apply any downward force to the rake. The handle of the embedding tool is held approximately 31.5 in. (0.8 m) off the floor and the rake is pulled slowly to avoid bouncing.

8.1.7 If the vacuum cleaner has not been energized for more than 60 min, energize the cleaner for 2 min at nameplate-rated voltage ($\pm 1\%$) and frequency (± 1 Hz) immediately preceding the test sequence of 8.1.8. For vacuum cleaners with dual nameplate voltage ratings, conduct testing at the highest voltage.

8.1.7.1 For a rotating agitator-type vacuum cleaner, place it such that the bristles clear the supporting surface and no loose dirt is picked up.

8.1.7.2 For a straight-air canister vacuum cleaner, operate with the rug tool unrestricted, positioned such that no loose dirt is picked up from the supporting surface.

8.1.8 Immediately following the 2-min “run-in,” de-energize the vacuum cleaner and place the vacuum cleaner nozzle on the test carpet so that the front edge of the vacuum cleaner coincides with the line defining the beginning of the 18-in. (46-cm) stroke. The forward stroke of the nozzle shall be in the direction of the carpet lay.