



Designation: G48 – 11 (Reapproved 2015)

# Standard Test Methods for Pitting and Crevice Corrosion Resistance of Stainless Steels and Related Alloys by Use of Ferric Chloride Solution<sup>1</sup>

This standard is issued under the fixed designation G48; the number immediately following the designation indicates the year of original adoption or, in the case of revision, the year of last revision. A number in parentheses indicates the year of last reapproval. A superscript epsilon ( $\epsilon$ ) indicates an editorial change since the last revision or reapproval.

## 1. Scope

1.1 These test methods cover procedures for the determination of the resistance of stainless steels and related alloys to pitting and crevice corrosion (see Terminology **G15**) when exposed to oxidizing chloride environments. Six procedures are described and identified as Methods A, B, C, D, E, and F.

1.1.1 *Method A*—Ferric chloride pitting test.

1.1.2 *Method B*—Ferric chloride crevice test.

1.1.3 *Method C*—Critical pitting temperature test for nickel-base and chromium-bearing alloys.

1.1.4 *Method D*—Critical crevice temperature test for nickel-base and chromium-bearing alloys.

1.1.5 *Method E*—Critical pitting temperature test for stainless steels.

1.1.6 *Method F*—Critical crevice temperature test for stainless steels.

1.2 Method A is designed to determine the relative pitting resistance of stainless steels and nickel-base, chromium-bearing alloys, whereas Method B can be used for determining both the pitting and crevice corrosion resistance of these alloys. Methods C, D, E and F allow for a ranking of alloys by minimum (critical) temperature to cause initiation of pitting corrosion and crevice corrosion, respectively, of stainless steels, nickel-base and chromium-bearing alloys in a standard ferric chloride solution.

1.3 These tests may be used to determine the effects of alloying additives, heat treatment, and surface finishes on pitting and crevice corrosion resistance.

1.4 The values stated in SI units are to be regarded as the standard. Other units are given in parentheses for information only.

1.5 *This standard does not purport to address all of the safety concerns, if any, associated with its use. It is the*

*responsibility of the user of this standard to establish appropriate safety and health practices and determine the applicability of regulatory limitations prior to use.*

## 2. Referenced Documents

2.1 *ASTM Standards*:<sup>2</sup>

**A262** Practices for Detecting Susceptibility to Intergranular Attack in Austenitic Stainless Steels

**D1193** Specification for Reagent Water

**E691** Practice for Conducting an Interlaboratory Study to Determine the Precision of a Test Method

**E1338** Guide for Identification of Metals and Alloys in Computerized Material Property Databases

**G1** Practice for Preparing, Cleaning, and Evaluating Corrosion Test Specimens

**G15** Terminology Relating to Corrosion and Corrosion Testing (Withdrawn 2010)<sup>3</sup>

**G46** Guide for Examination and Evaluation of Pitting Corrosion

**G107** Guide for Formats for Collection and Compilation of Corrosion Data for Metals for Computerized Database Input

## 3. Terminology

3.1 *Definitions of Terms Specific to This Standard:*

3.1.1 *critical crevice temperature, n*—the minimum temperature ( $^{\circ}\text{C}$ ) to produce crevice attack at least 0.025-mm (0.001-in.) deep on the bold surface of the specimen beneath the crevice washer, edge attack ignored.

3.1.2 *critical pitting temperature, n*—the minimum temperature ( $^{\circ}\text{C}$ ) to produce pitting attack at least 0.025-mm (0.001-in.) deep on the bold surface of the specimen, edge attack ignored.

3.2 The terminology used herein, if not specifically defined otherwise, shall be in accordance with Terminology **G15**.

<sup>1</sup> These test methods are under the jurisdiction of ASTM Committee **G01** on Corrosion of Metals and are the direct responsibility of Subcommittee **G01.05** on Laboratory Corrosion Tests.

Current edition approved Nov. 1, 2015. Published November 2015. Originally approved in 1976. Last previous edition approved in 2011 as G48–11. DOI: 10.1520/G0048-11R15.

<sup>2</sup> For referenced ASTM standards, visit the ASTM website, [www.astm.org](http://www.astm.org), or contact ASTM Customer Service at [service@astm.org](mailto:service@astm.org). For *Annual Book of ASTM Standards* volume information, refer to the standard's Document Summary page on the ASTM website.

<sup>3</sup> The last approved version of this historical standard is referenced on [www.astm.org](http://www.astm.org).

Definitions provided herein and not given in Terminology **G15** are limited only to this standard.

#### 4. Significance and Use

4.1 These test methods describe laboratory tests for comparing the resistance of stainless steels and related alloys to the initiation of pitting and crevice corrosion. The results may be used for ranking alloys in order of increasing resistance to pitting and crevice corrosion initiation under the specific conditions of these methods. Methods A and B are designed to cause the breakdown of Type 304 at room temperature.

4.2 The use of ferric chloride solutions is justified because it is related to, but not the same as, that within a pit or crevice site on a ferrous alloy in chloride bearing environments (**1, 2**).<sup>4</sup> The presence of an inert crevice former of consistent dimension on a surface is regarded as sufficient specification of crevice geometry to assess relative crevice corrosion susceptibility.

4.3 The relative performance of alloys in ferric chloride solution tests has been correlated to performance in certain real environments, such as natural seawater at ambient temperature (**3**) and strongly oxidizing, low pH, chloride containing environments (**4**), but several exceptions have been reported (**4-7**).

4.4 Methods A, B, C, D, E, and F can be used to rank the relative resistance of stainless steels and nickel base alloys to pitting and crevice corrosion in chloride-containing environments. No statement can be made about resistance of alloys in environments that do not contain chlorides.

4.4.1 Methods A, B, C, D, E, and F were designed to accelerate the time to initiate localized corrosion relative to most natural environments. Consequently, the degree of corrosion damage that occurs during testing will generally be greater than that in natural environments in any similar time period.

4.4.2 No statement regarding localized corrosion propagation can be made based on the results of Methods A, B, C, D, E or F.

4.4.3 Surface preparation can significantly influence results. Therefore, grinding and pickling of the specimen will mean that the results may not be representative of the conditions of the actual piece from which the sample was taken.

NOTE 1—Grinding or pickling on stainless steel surfaces may destroy the passive layer. A 24-h air passivation after grinding or pickling is sufficient to minimize these differences (**8**).

4.4.4 The procedures in Methods C, D, E and F for measuring critical pitting corrosion temperature and critical crevice corrosion temperature have no bias because the values are defined only in terms of these test methods.

NOTE 2—When testing as-welded, cylindrical, or other non-flat samples, the standard crevice formers will not provide uniform contact. The use of contoured crevice formers may be considered in such situations, but the use of a pitting test (Practices A, C, or E) should be considered.

#### 5. Apparatus

5.1 *Glassware*—Methods A, B, C, D, E, and F provide an option to use either wide mouth flasks or suitable sized test

<sup>4</sup> The boldface numbers in parentheses refer to the list of references at the end of this standard.

tubes. Condensers are required for elevated temperature testing when solution evaporation may occur. Glass cradles or hooks also may be required.

5.1.1 *Flask Requirements*, 1000-mL wide mouth. Tall form or Erlenmeyer flasks can be used. The mouth of the flask shall have a diameter of about 40 mm (1.6 in.) to allow passage of the test specimen and the support.

5.1.2 *Test Tube Requirements*, the diameter of the test tube shall also be about 40 mm (1.6 in.) in diameter. If testing requires use of a condenser (described below), the test tube length shall be about 300 mm (about 12 in.); otherwise, the length can be about 150 to 200 mm (about 6 in. to 8 in.).

5.1.3 *Condensers, Vents and Covers*:

5.1.3.1 A variety of condensers may be used in conjunction with the flasks described in 5.1.1. These include the cold finger-type (see, for example, Practices **A262**, Practice C) or Allihn type condensers having straight tube ends or tapered ground joints. Straight end condensers can be inserted through a bored rubber stopper. Likewise, a simple U tube condenser can be fashioned.

NOTE 3—The use of ground joint condensers requires that the mouth of the flask have a corresponding joint.

5.1.3.2 *U Tube Condensers*, fitted through holes in an appropriate size rubber stopper can be used in conjunction with the 300-mm test tube described in 5.1.2.

5.1.3.3 When evaporation is not a significant problem, flasks can be covered with a watch glass. Also, flasks as well as test tubes can be covered with loosely fitted stoppers or plastic or paraffin type wraps.

NOTE 4—Venting must always be considered due to the possible build up of gas pressure that may result from the corrosion process.

5.1.4 *Specimen Supports*:

5.1.4.1 One advantage of using test tubes is that specimen supports are not required. However, placement of the specimen does create the possible opportunity for crevice corrosion to occur along the edge.

NOTE 5—See **14.2** concerning edge attack.

5.1.4.2 When using flasks, specimens can be supported on cradles or hooks. Cradles, such as those shown in **Fig. 1**, eliminate the necessity for drilling a support hole in the test specimen. While the use of hooks requires that a specimen support hole be provided, the hooks, as contrasted to the cradle, are easier to fashion. Moreover, they create only one potential crevice site whereas multiple sites are possible with the cradle.

NOTE 6—A TFE-fluorocarbon cradle may be substituted for glass.

5.1.4.3 The use of supports for Methods B, D, and F crevice corrosion specimens is optional.

5.2 *Water or Oil Bath*, constant temperature.

5.2.1 For Methods A and B, the recommended test temperatures are  $22 \pm 2^\circ\text{C}$  or  $50 \pm 2^\circ\text{C}$ , or both.

5.2.2 For Methods C, D, E, and F, the bath shall have the capability of providing constant temperature between  $0^\circ\text{C}$  and  $85^\circ\text{C} \pm 1^\circ\text{C}$ .

5.3 *Crevice Formers—Method B*:

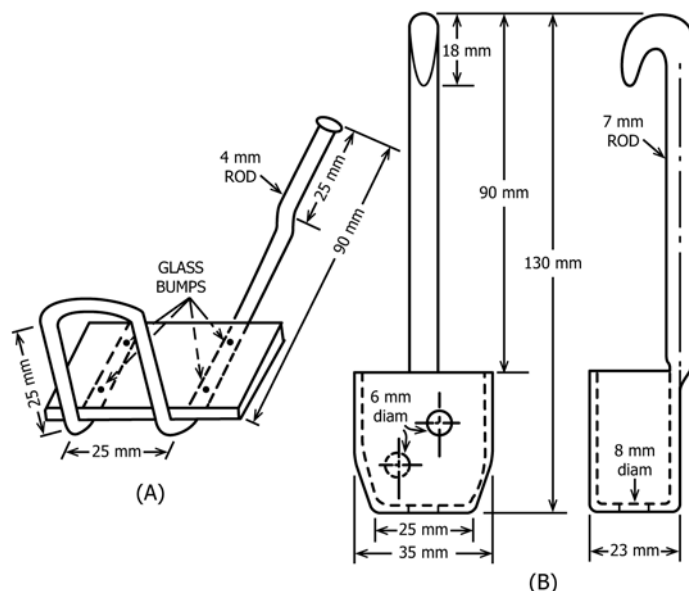

FIG. 1 Examples of Glass Cradles that Can Be Used to Support the Specimen

5.3.1 *Cylindrical TFE-fluorocarbon Blocks*, two for each test specimen. Each block shall be 12.7-mm (0.5 in.) in diameter and 12.7-mm high, with perpendicular grooves 1.6-mm (0.063 in.) wide and 1.6-mm deep cut in the top of each cylinder for retention of the O-ring or rubber bands. Blocks can be machined from bar or rod stock.

NOTE 7—When testing as-welded, cylindrical, or other non-flat samples, the standard crevice formers will not provide uniform contact. The use of contoured crevice formers may be considered in such situations, but the use of the pitting test (Practice A) should be considered. The problem of matching the crevice former to the sample surface becomes more difficult as the radius of the surface becomes smaller.

5.3.2 *Fluorinated Elastomers O-rings, or Rubber Bands*, (low sulfur (0.02 % max)), two for each test specimen.

NOTE 8—It is good practice to use all O-rings or all rubber bands in a given test program.

5.3.2.1 O-rings shall be 1.75 mm (0.070 in.) in cross section; one ring with an inside diameter of about 20 mm (0.8 in.) and one with an inside diameter of about 30 mm (1.1 in.). Rubber bands shall be one No. 12 (38-mm (1.5-in.) long) and one No. 14 (51-mm (2-in.) long).

NOTE 9—Rubber bands or O-rings can be boiled in water prior to use to ensure the removal of water-soluble ingredients that might affect corrosion.

5.4 *Crevice Formers—Methods D and F:*

5.4.1 A *Multiple Crevice Assembly (MCA)*, consisting of two TFE-fluorocarbon segmented washers, each having a number of grooves and plateaus, shall be used. The crevice

design shown in Fig. 2 is one of a number of variations of the multiple crevice assembly that is in use and commercially available.<sup>5</sup>

NOTE 10—When testing as-welded, cylindrical, or other non-flat samples, the standard crevice formers will not provide uniform contact. The use of contoured crevice formers may be considered in such situations, but the use of pitting tests (Practices C or E) should be considered. The problem of matching the crevice former to the sample surface becomes more difficult as the radius of the surface becomes smaller.

5.4.2 *Reuse of Multiple Crevice Assemblies*, when assembled to the specified torque, the TFE-fluorocarbon segmented washers should not deform during testing. Before reuse, each washer should be inspected for evidence of distortion and other damage. If so affected, they should be discarded. In some cases, the crevice formers may become stained with corrosion products from the tested alloy. Generally, this staining can be removed by immersion in dilute HCl (for example, 5-10% by volume) at room temperature, followed by brushing with mild detergent and through rinsing with water.

5.4.3 *Fasteners*, one alloy UNS N10276 (or similarly resistant alloy) fastener is required for each assembly. Each assembly comprises a threaded bolt and nut plus two washers. The bolt length shall be sized to allow passage through the mouth of the glassware described in 5.1.

5.5 *Tools and Instruments:*

5.5.1 A 6.35-mm (1/4-in.) torque limiting nut driver is required for assembly of the Methods D and F crevice test specimen.

<sup>5</sup> The sole source of supply of the apparatus known to the committee at this time is Metal Samples Co., Inc., P.O. Box 8, Route 1 Box 152, Munford, AL 36268. If you are aware of alternative suppliers, please provide this information to ASTM Headquarters. Your comments will receive careful consideration at a meeting of the responsible technical committee,<sup>1</sup> which you may attend.

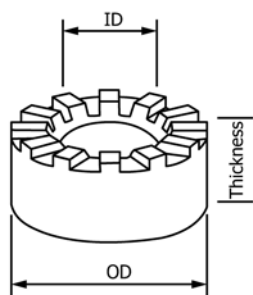

Type	Crevice Washer Dimensions						Number of Slots
	ID		OD		Thickness		
	mm	in	mm	in	mm	in	
A	6.73	0.265	15.9	0.625	2.54	0.100	12
B	6.73	0.265	15.9	0.625	6.34	0.250	12
C	9.92	0.391	15.9	0.625	6.34	0.250	12

FIG. 2 TFE-fluorocarbon Crevice Washers

5.5.2 *Low Power Microscope*, (for example, 20× magnification) for pit detection.

5.5.3 *Needle Point Dial Depth Indicator or Focusing Microscope*, to determine the depth of pitting or crevice corrosion, or both.

5.5.4 *Electronic Balance* (optional), to determine specimen mass to the nearest 0.0001 g.

5.5.5 *Camera* (optional), to photographically record the mode and extent of any localized corrosion.

## 6. Ferric Chloride Test Solution

6.1 For Methods A and B, dissolve 100 g of reagent grade ferric chloride,  $\text{FeCl}_3 \cdot 6\text{H}_2\text{O}$ , in 900 mL of Type IV reagent water (Specification D1193) (about 6 %  $\text{FeCl}_3$  by mass). Filter through glass wool or filter paper to remove insoluble particles if present.

6.2 For Methods C, D, E, and F, dissolve 68.72 g of reagent grade ferric chloride,  $\text{FeCl}_3 \cdot 6\text{H}_2\text{O}$  in 600 mL of reagent water and add 16 mL of reagent grade concentrated (36.5–38.0 %) hydrochloric acid (HCl). This will produce a solution containing about 6 %  $\text{FeCl}$  by mass and 1 % HCl resulting in a pH controlled environment over the test temperatures (9).

## 7. Test Specimens

7.1 A test specimen 25 by 50 mm (1 by 2 in.) is recommended as a standard size, although various shapes and sizes can be tested by this method. All specimens in a test series should have the same dimensions when comparisons are to be made. Unless end-grain pitting is an integral part of the evaluation, the proportion of end-grain surface to specimen surface should be kept as small as possible given the limitations of specimen sizes because of the susceptibility of end-grain surfaces to pitting.

NOTE 11—The thickness of the specimen in Method B can influence the tightness of the crevice and the test results.

NOTE 12—End-grain attack in Methods C, D, E, and F may not be as prevalent in a test in which low test temperatures are anticipated.

7.2 When specimens are cut by shearing, the deformed material should be removed by machining or grinding prior to testing unless the corrosion resistance of the sheared edges is being evaluated. It is good practice to remove deformed edges to the thickness of the material.

7.3 For Methods D and F, a sufficient hole should be drilled and chamfered in the center of the specimen to accommodate the bolt and insulating sleeve used to attach the crevice device.

7.4 All surfaces of the specimen should be polished to a uniform finish. A 120-grit abrasive paper has been found to provide a satisfactory standard finish. Wet polishing is preferred, but if dry polishing is used, it should be done slowly to avoid overheating. The sharp edges of a specimen should be rounded to avoid cutting rubber bands or O-rings.

NOTE 13—While a polished surface is preferred for uniformity, the test may be varied at the discretion of the investigator to evaluate other surface finishes, such as a mill finish.

7.5 Measure the dimensions of the specimen, and calculate the total exposed area of interest.

7.6 Clean specimen surfaces with magnesium oxide paste or equivalent, rinse well with water, dip in acetone or methanol, and air-dry.

7.7 Weigh each specimen to the nearest 0.001 g or better and store in a desiccator until ready for use (see Practice G1).

## 8. Method A—Ferric Chloride Pitting Test

### 8.1 Procedure:

8.1.1 Pour 600 mL of the ferric chloride test solution into the 1000-mL test beaker. If specimens larger than the standard are used, provide a solution volume of at least 5 mL/cm<sup>2</sup> (30 mL/in.<sup>2</sup>) of specimen surface area. Transfer the test beaker to a constant temperature bath and allow the test solution to come to the equilibrium temperature of interest. Recommended temperatures for evaluation are 22 ± 2°C and 50 ± 2°C.

8.1.2 Place the specimen in a glass cradle and immerse in the test solution after it has reached the desired temperature. Maintain test solution temperature throughout the test.

8.1.3 Cover the test vessel with a watch glass. A reasonable test period is 72 h, although variations may be used at the discretion of the investigator and depend on the materials being evaluated.

8.1.4 Remove the specimens, rinse with water and scrub with a nylon bristle brush under running water to remove corrosion products, dip in acetone or methanol, and air-dry. Ultrasonic cleaning may be used as a substitute method in cases in which it is difficult to remove corrosion products from deep pits.

8.1.5 Weigh each specimen to 0.001 g or better and reserve for examination (see Practice G1).

## 9. Method B—Ferric Chloride Crevice Corrosion Test (10)

### 9.1 Procedure:

9.1.1 Add 150 mL of ferric chloride solution to each test tube, insert a rubber stopper, and place the tube in a thermostated bath until it comes to the equilibrium temperature of interest. Recommended temperatures for evaluation are 22 ± 2°C and 50 ± 2°C.

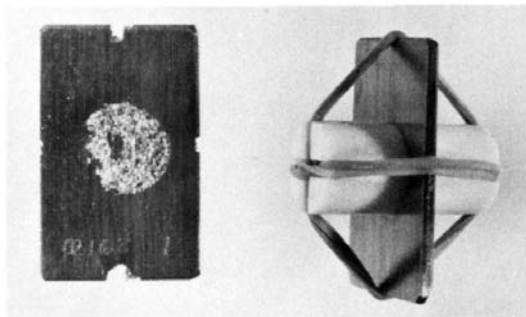

(a) Specimen After Test with Attack at Four Crevices Under Rubber Bands and Under One Block

(b) Assembled Crevice Test Specimen

FIG. 3 Ferric Chloride Crevice Test Specimen

9.1.2 Fasten two TFE-fluorocarbon blocks to the test specimen with O-rings or a double loop of each of two rubber bands as shown in Fig. 3. Use plastic gloves to avoid hand contact with metal surfaces during this operation. Use the small O-ring or the No. 12 rubber band for the 25-mm (1-in.) dimension and the large O-ring or the No. 14 rubber band for the 50-mm (2-in.) dimension.

9.1.3 After the test solution has reached the desired temperature, tilt the tube at a 45° angle and slide the test specimen to the bottom of the tube, replace the stopper, and return the tube to the bath.

9.1.4 A reasonable test period is 72 h, although variations may be used at the discretion of the investigator and depend on the materials being evaluated. Specimens may be inspected at intervals by decanting the test solution into a clean beaker and sliding the specimen from the test tube. Rinse the specimen in water and examine under the four points of contact for the O-rings or rubber bands and under both TFE-fluorocarbon blocks. If further exposure is required, the specimen and solution should be returned to the test tube before the specimen dries and the test tube should be immediately returned to the bath.

NOTE 14—The removal of specimens for inspection may affect the rate of corrosion, and caution should be observed when comparing these results with those obtained from constant immersion tests.

9.1.5 After the test has been completed, remove the test specimens, rinse with water, and scrub with a nylon bristle brush under running water to remove corrosion products, dip in acetone or methanol, and air-dry. Ultrasonic cleaning may be used in those cases in which it is difficult to remove corrosion products from deep pits or crevices.

9.1.6 Weigh each specimen to the nearest 0.001 g or better and reserve for examination.

## 10. Method C—Critical Pitting Temperature Test for Nickel-Base and Chromium-Bearing Alloys:

NOTE 15—See Table 1.

### 10.1 Procedure:

10.1.1 Pour 600 mL of acidified ferric chloride test solution into the test container. If specimens larger than the standard are used, provide a solution volume of at least 5 mL/cm<sup>2</sup>

(30 mL/in.<sup>2</sup>) of surface area. Cover the container with a watch glass, transfer to a constant temperature bath, and allow to come to the equilibrium temperature of interest. Verify the temperature before starting the test.

10.1.2 If test tubes are used instead of a 1000-mL test container, 150 mL of test solution shall be added.

10.1.3 Place the specimen in a glass cradle and immerse in the test solution after it has reached the desired temperature. The starting temperature may be estimated by the following equation (10, 11).

$$\text{CPT } (^{\circ}\text{C}) = (2.5 \times \% \text{Cr}) + (7.6 \times \% \text{Mo}) + (31.9 \times \% \text{N}) - 41.0 \quad (1)$$

Testing shall begin at the nearest increment of 5°C, estimated by the above equation. The minimum temperature of test is 0°C and the maximum temperature of test is 85°C. No more than one specimen shall be placed in a test container. Replace the watch glass on the container. Maintain the temperature ( $\pm 1^{\circ}\text{C}$  ( $\pm 1.8^{\circ}\text{F}$ )) throughout the test period. The standard test period is 72 h. This test period was evaluated by interlaboratory testing, 16.1.2, and is required to produce attack on some highly corrosion resistant nickel-based alloys. The test period must be reported as indicated in 15.1.

NOTE 16—Critical pitting or crevice testing is likely to require three to five replicate samples to determine the critical temperature for each alloy/condition.

NOTE 17—While testing may be done at a higher temperature, 85°C was the maximum temperature of the test in the round robin.

10.1.4 At the end of the test period, remove the specimen, rinse with water, scrub with a nylon bristle brush under running water to remove corrosion products, dip in acetone or methanol, and dry.

10.1.5 Inspection is done in accordance with Section 14. Pitting corrosion is considered to be present if the local attack is 0.025 mm (0.001 in.) or greater in depth.

10.1.5.1 If minimum or greater pitting attack is observed, lower the bath temperature 5°C, and using a new specimen and fresh solution, repeat steps 10.1.1 to 10.1.5, or

10.1.5.2 If less than minimum pitting attack is observed, raise the bath temperature 10°C, and using a new specimen and fresh solution, repeat steps 10.1.1 – 10.1.5.

## 11. Method D—Critical Crevice Temperature Test for Nickel-Based and Chromium-Bearing Alloys (12):

NOTE 18—See Table 1.

### 11.1 Procedure:

11.1.1 Apply the two crevice washers to the specimen. A TFE-fluorocarbon tubular sleeve (for electrical isolation), and a bolt, a nut, and flat washers of UNS N10276 may be used to fasten the crevice washers to the specimen, as illustrated in Fig. 4. Insulating sleeves shall be used around the bolt and the specimen shall be checked for electrical contact with the bolt. The torque on the bolt influences the tightness of the crevice and the test results. A torque of 0.28 Nm (40 in.-oz) shall be applied using a 6.35-mm (1/4-in.) drive torque limiting nut-driver. The torque must be reported as indicated in 15.1.

NOTE 19—The torque of 0.28 Nm (40 in.-oz) was evaluated by inter-laboratory testing, 16.1.2.

NOTE 20—(a) Titanium bolts, nuts, and flat washers may also be used

TABLE 1 Results of First Interlaboratory Test Program

NOTE 1—Minimum temperature (°C) to produce attack at least 0.025-mm (0.001-in.) deep on bold surface of specimen. Edge attack ignored.

Alloy/Laboratory	Method C—CPT Critical Pitting Corrosion Temperature (C)				Method D—CCT Critical Crevice Corrosion Temperature (C)			
	UNS S31603	UNS N08367	UNS S44735	UNS N06022	UNS S31603	UNS N08367	UNS S44735	UNS N06022
1	20/20/20	75/ <sup>A</sup> /75	85/85/85	>85/>85/>85	<0/<0/<0	30/30/30	42/35/42	50/ <sup>A</sup> /50
2	20/20/20	70/70/70	80/80/80	>85/>85/>85	<0/<0/<0	25/25/25	35/35/ <sup>A</sup>	50/55/55
3	20/20/20	85/85/85	75/85/85	>85/>85/>85	<0/<0/<0	25/30/30	35/40/40	55/60/60
4	19/19	75/80	81/81	>85/>85	<0/<0	34/34	40/40	67/67
5	20/20/20	75/75/75	70/70/75	>85/>85/>85	<0/<0/<0	20/20/20	45/45/45	
6	20/20	75/80	75/85	>85/>85	<0/<0	30/30	40/40	55/55

<sup>A</sup> Test run but no attack observed.

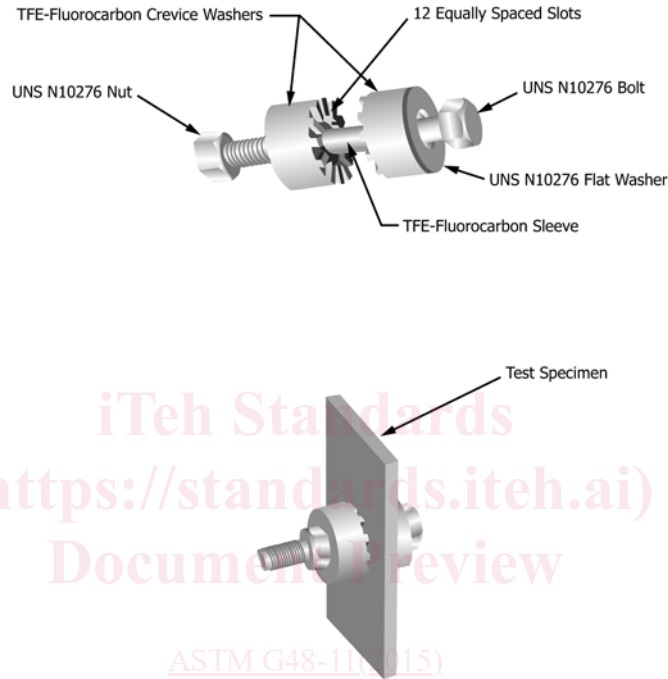

FIG. 4 Method D and F Crevice Assembly

to attach the crevice washers to the specimen. (b) Different crevice devices may give different results for the same torque.

11.1.2 Pour 600 mL of acidified ferric chloride test solution into the 1000-mL test container. Cover the container with a watch glass, transfer to a constant temperature bath, and allow to come to equilibrium temperature of interest. Verify the temperature before starting the test.

11.1.3 If test tubes are used instead of a 1000-mL test container, 150 mL of test solution shall be added.

11.1.4 Immerse the specimen in the test solution after it has reached the desired temperature. The starting temperature may be estimated for nickel base alloys by the following equation (13):

$$CCT (°C) = (1.5 \times \% Cr) + (1.9 \times \% Mo) + (4.9 \times \% Nb) + (8.6 \times \% W) - 36.2 \quad (2)$$

Testing shall begin at the nearest increment of 5°C, estimated by the above equations. The minimum temperature of test is 0°C and the maximum temperature of test is 85°C (see Note 15). No more than one specimen shall be placed in a test

container. Replace the watch glass on the container and maintain the temperature ( $\pm 1^\circ C$  ( $\pm 1.8^\circ F$ )) throughout the test period. The standard test period is 72 h. This test period was evaluated by interlaboratory testing, 16.1.2, and is required to produce attack on some highly corrosion resistant nickel-based alloys (12, 13). The test period must be reported as indicated in 15.1.

11.1.5 At the end of the test period, remove the specimen, rinse with water, and scrub with a nylon bristle brush under running water to remove corrosion products, dip in acetone or methanol, and dry.

11.1.6 Inspection is done in accordance with Section 14. Crevice corrosion is considered to be present if the local attack is 0.025 mm (0.001 in.) or greater in depth.

11.1.6.1 If minimum or greater crevice corrosion attack is observed, lower the bath temperature 5°C, and using a new specimen and fresh solution, repeat steps 11.1.1 – 11.1.6, or

11.1.6.2 If less than minimum crevice corrosion attack is observed, raise the bath temperature 10°C, and using a new specimen and fresh solution, repeat steps 11.1.1 – 11.1.6.