



Standard Specification for Fiber-Reinforced Polymer (FRP) Gratings Used in Marine Construction and Shipbuilding¹

This standard is issued under the fixed designation F3059; the number immediately following the designation indicates the year of original adoption or, in the case of revision, the year of last revision. A number in parentheses indicates the year of last reapproval. A superscript epsilon (ϵ) indicates an editorial change since the last revision or reapproval.

1. Scope

1.1 This specification provides the testing and performance requirements for fiber-reinforced polymer (FRP) gratings used in marine construction and shipbuilding as an equivalency to the specification of steel gratings rated for a maximum load of 94 lbf/ft² (4.5 kN/m²).

1.2 The purpose of this specification is to ensure that all FRP gratings are designed and tested appropriately to ensure personnel safety. It does not address the ability of the gratings to support either moving or stationary equipment during or after a fire exposure.

1.3 This specification addresses fire conditions based on Test Methods E119 fire exposure and does not address hydrocarbon pool or jet fire exposures.

1.4 This specification is intended for use by all persons designing, manufacturing, testing, inspecting, and maintaining FRP gratings.

1.5 *Units*—The values stated in inch-pound units are to be regarded as the standard. The values given in parentheses are mathematical conversions to SI units that are provided for information only and are not considered standard.

1.6 This specification does not constitute regulations or ship classification rules, which shall be consulted where applicable.

1.7 *This standard does not purport to address all of the safety concerns, if any, associated with its use. It is the responsibility of the user of this standard to establish appropriate safety and health practices and determine the applicability of regulatory limitations prior to use.*

2. Referenced Documents

2.1 *ASTM Standards*:²

- B117 Practice for Operating Salt Spray (Fog) Apparatus
- D2047 Test Method for Static Coefficient of Friction of Polish-Coated Flooring Surfaces as Measured by the James Machine
- D4060 Test Method for Abrasion Resistance of Organic Coatings by the Taber Abraser
- D4329 Practice for Fluorescent Ultraviolet (UV) Lamp Apparatus Exposure of Plastics
- E84 Test Method for Surface Burning Characteristics of Building Materials
- E119 Test Methods for Fire Tests of Building Construction and Materials
- E695 Test Method of Measuring Relative Resistance of Wall, Floor, and Roof Construction to Impact Loading

2.2 *Other Standards*:

- 46 CFR 159 Shipping—Approval of Equipment and Materials³
- NVIC 02-06 Follow-Up Programs for Fire-Safety Type-Approved Products⁴
- NVIC 9-97 Change 1—Guide to Structural Fire Protection⁵

¹ This specification is under the jurisdiction of ASTM Committee F25 on Ships and Marine Technology and is the direct responsibility of Subcommittee F25.03 on Outfitting and Deck Machinery.

Current edition approved July 1, 2014; Nov. 15, 2015. Published August 2014; December 2015. Originally approved in 2014. Last previous edition approved in 2014 as F3059–14. DOI: 10.1520/F3059-14; 10.1520/F3059-15.

² For referenced ASTM standards, visit the ASTM website, www.astm.org, or contact ASTM Customer Service at service@astm.org. For *Annual Book of ASTM Standards* volume information, refer to the standard's Document Summary page on the ASTM website.

³ Available from U.S. Government Printing Office Superintendent of Documents, 732 N. Capitol St., NW, Mail Stop: SDE, Washington, DC 20401, <http://www.access.gpo.gov>.

⁴ Available from United States Coast Guard (USCG), U.S. Coast Guard Headquarters, 2100 2nd ST SW Stop 7000, Washington, DC, 20593-7000; 2703 Martin Luther King Jr. Ave. SE Stop 7509, Washington, DC, 20593-7509, <http://www.uscg.mil/hq/cg5/cg5214/docs/NVIC02-06.pdf>.

⁵ Available from United States Coast Guard (USCG), U.S. Coast Guard Headquarters, 2100 2nd ST SW Stop 7000, Washington, DC, 20593-7000; 2703 Martin Luther King Jr. Ave. SE Stop 7509, Washington, DC, 20593-7509, <http://www.uscg.mil/hq/cg5/nvic/pdf/1997/n9-97ch1.pdf>.

3. Terminology

3.1 Definitions:

3.1.1 *compression molding, v*—manufacturing process involving match die molds that compress the fiber reinforced matrix, generally under pressure and heat, to produce the finished product.

3.1.2 *fiber-reinforced polymer, FRP, n*—composite material made of a resin matrix reinforced with fibers.

3.1.2.1 Discussion—

The fibers are usually made of glass or carbon fiber, while the polymer is usually an epoxy, vinyl ester, or polyester thermosetting plastic. The term “polymer” is sometimes replaced by “plastic.”

3.1.3 *fire integrity, n*—ability of a structure to retain functionality after a fire.

3.1.3.1 Discussion—

Fire integrity levels for FRP gratings are described as (from lowest to highest) Level 3, Level 2, and Level 1. Level 0 gratings are not qualified for fire integrity.

3.1.4 *glass-reinforced polymer, GRP, n*—fiber-reinforced polymer made of a resin matrix reinforced by glass fibers.

3.1.5 *molded grating, n*—FRP grating produced by the open mold process in which dry glass fiber and thermoset resin is placed in the mold in both directions.

3.1.5.1 Discussion—

After filling the mold with the designated amount of material, the resin is allowed to cure in the open mold. Square mesh molded grating has nearly equal strength and stiffness in longitudinal and transverse directions. Molded grating is usually manufactured in square mesh or rectangular mesh configurations. See Fig. 1 and Fig. 2.

3.1.6 *open molding, v*—manual process involving the combination of liquid resin and fiber reinforcements in an open mold to produce a finished part resembling the inverse of the mold.

3.1.6.1 Discussion—

Liquid resin and continuous fibers are systematically laid in a mold—layer upon layer manually to a desired thickness and panel dimension.

3.1.7 *pultruded grating, n*—grating produced from an assembly of pultruded structural shapes assembled into a grid pattern.

3.1.7.1 Discussion—

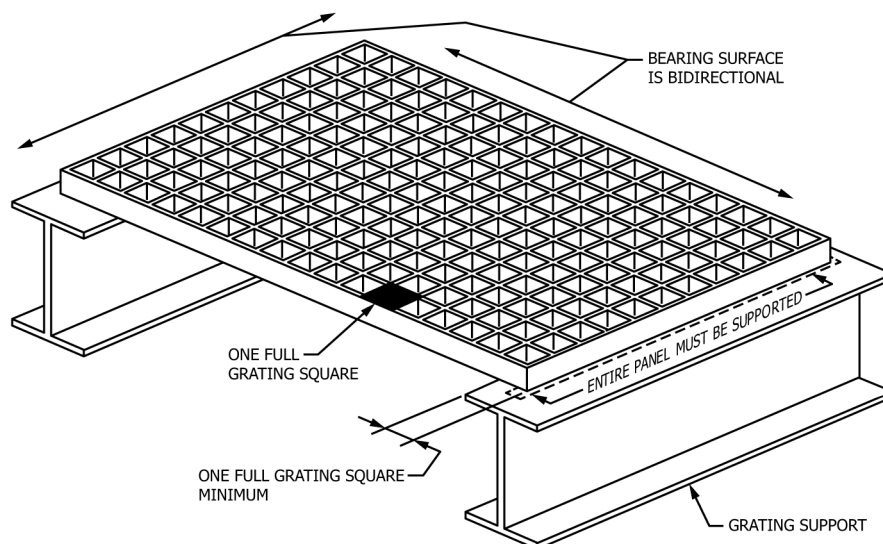

FIG. 1 Square Mesh Molded Grating

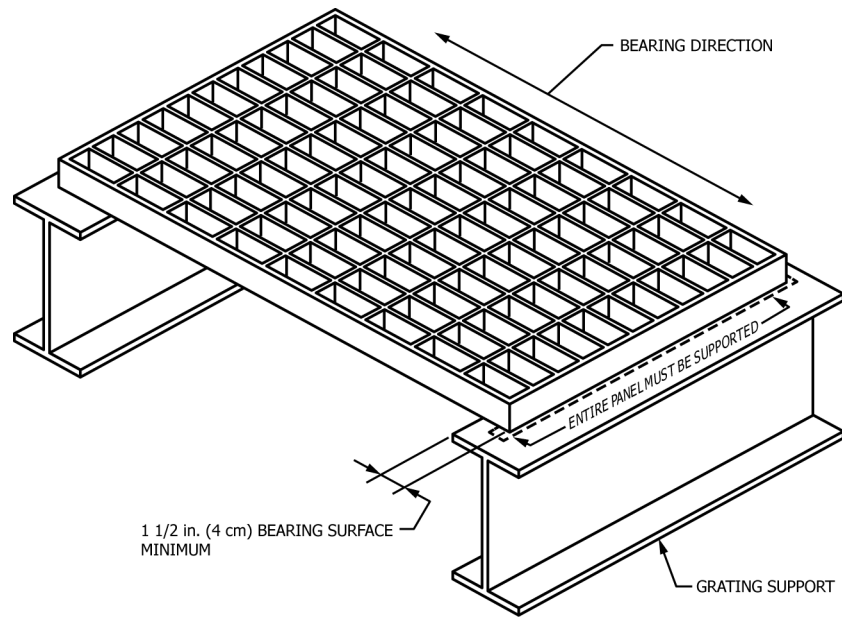

FIG. 2 Rectangular Mesh Molded Grating

Pultruded FRP grating products are assembled from bearing bars and cross rods manufactured from the pultrusion process as shown in Fig. 3. Pultruded grating has more strength and stiffness in the direction of the bearing bars.

3.1.8 *pultrusion, n*—manufacturing process to form continuous lengths of reinforced polymer structural shapes.

3.1.9 *qualified span, n*—FRP grating span used during preload and post load fire tests [minimum 44 in. (112 cm)].

3.1.10 *surface flame spread, n*—propagation of a flame away from the source of ignition across the surface of the specimen.

3.2 *Definitions of Terms Specific to This Standard:*

3.2.1 *shall, v*—in this specification, indicates a mandatory requirement.

3.2.2 *should, n*—in this specification, indicates a recommended requirement.

3.3 *Abbreviations:*

3.3.1 *AFFF*—Aqueous film-forming foam

3.3.2 *AHJ*—Authority having jurisdiction

3.3.3 *ASTM*—American Society for Testing and Materials

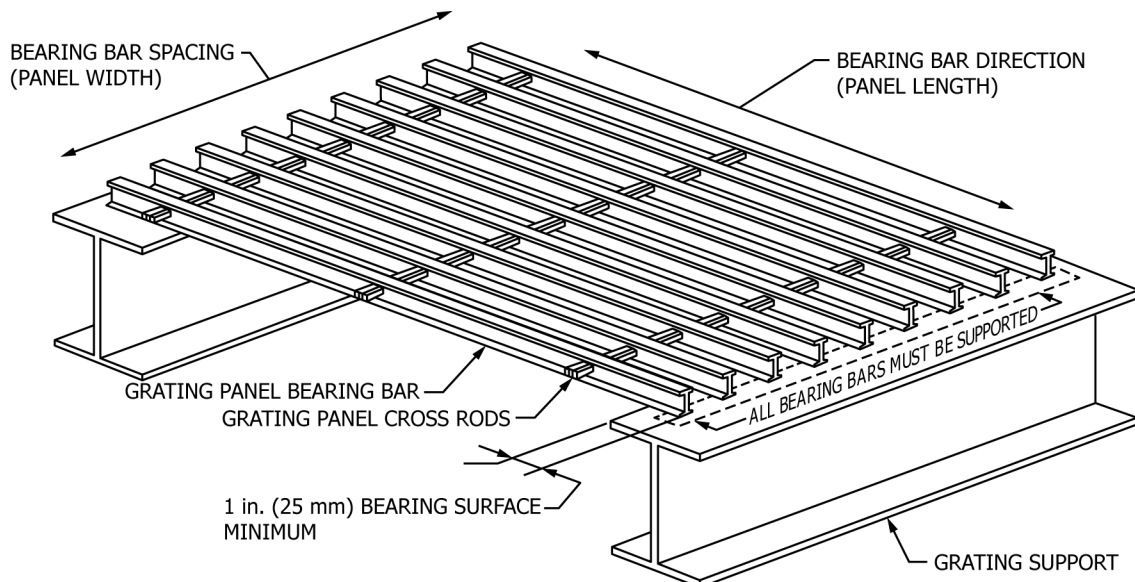

FIG. 3 Pultruded Grating

- 3.3.4 *L1*—Level 1 fire integrity grating
- 3.3.5 *L2*—Level 2 fire integrity grating
- 3.3.6 *L3*—Level 3 fire integrity grating
- 3.3.7 *L0*—Flame spread only
- 3.3.8 *MODU*—Mobile offshore drilling unit
- 3.3.9 *NVIC*—Navigation and Vessel Inspection Circular
- 3.3.10 *USCG*—U.S. Coast Guard
- 3.3.11 *UV*—Ultraviolet

4. Significance and Use

4.1 This specification is for FRP gratings used in machinery spaces, cargo areas, and on-deck areas but not within accommodation, service, control spaces, and areas where smoke and toxicity is a concern. The test requirements and criteria for FRP gratings have been developed based on the expected environmental conditions, intended use, and fire hazard the gratings could be exposed to in conjunction with requirements for means of escape and fire brigade access to the area where the FRP gratings will be located. The structural fire integrity test requirements have been developed based on comparative testing with steel gratings rated for maximum load of 94 lbf/ft² (4.5 kN/m²). The structural fire integrity requirements for the specific locations are summarized in **Table 1**. The fire test requirements include surface flammability testing and structural fire integrity testing with three levels of structural fire integrity that may be achieved as follows:

4.1.1 *Level 1 (L1)*—FRP gratings meeting the L1 performance criteria provide the highest degree of safety and are intended for use in escape routes or areas in which access for firefighting, emergency operation, or rescue is needed after a significant fire exposure that may weaken the gratings. Level 1 gratings may also be used in any areas requiring Levels 2 or 3 gratings.

4.1.2 *Level 2 (L2)*—FRP gratings meeting the L2 performance criteria are intended for use in areas in which personnel may need to assemble after the grating has been exposed to a fire and are tested to ensure that they will be able to sustain a post-fire structural loading. Areas in which L2 gratings are specified include temporary safe refuge or lifeboat embarkation stations. Level 2 gratings may also be used in any areas requiring Level 3 gratings.

4.1.3 *Level 3 (L3)*—FRP gratings meeting the L3 performance criteria are intended for use in areas used as egress routes or that may require access for firefighting, emergency operations, or rescue during or shortly after exposure to a very limited fire not likely involving flammable liquids.

4.1.4 *Level 0 (L0)*—FRP gratings tested to Test Method **E84** with a flame spread index ≤ 20 and a smoke developed index of ≤ 450 . L0 FRP gratings have no level of fire integrity. L0 gratings are used for personnel walkways, catwalks, ladders, platforms, or access areas in cargo holds and tanks.

4.2 These test methods in this specification do not provide the following:

4.2.1 Full information as to the performance of the FRP grating with materials, construction, dimensions, coatings, and so forth, other than tested.

4.3 In these test methods, the test specimens are subjected to one or more specific tests under laboratory conditions. When different test conditions are substituted or the end-use conditions are changed, it is not always possible by, or from, these test methods to predict changes to the characteristics measured. Therefore, the results of these laboratory tests are valid only for the test conditions described in these test methods.

4.4 The fire-resistance test methods specified herein require test specimens to be exposed to a standard fire that is controlled to achieve specified temperatures throughout a specified time period or heat exposure. These are followed by the application of specified loads. These test methods provide a relative measure of performance under the specified test conditions. The fire exposure is not representative of all fire conditions. Variation from the test conditions or test specimen construction, such as size, materials, method of assembly, and so forth, may affect the fire-test response. For these reasons, evaluation of such variations may be required for application to construction in the field. However, variations in the required test exposure conditions are considered outside the scope of this specification.

5. Sampling

5.1 Sampling methods shall be as required to provide reasonable assurance that the test samples are truly representative of the standard manufactured product. When required, test specimens of products shall be sampled at the manufacturing facility by personnel representing an accredited testing laboratory, accredited inspection agency, or accredited certification agency. Sampling at a warehouse or distribution center in lieu of sampling at the manufacturing facility is permitted provided the testing laboratory, inspection agency, or certification agency samples the materials and correlates the sampled materials with the finished product specification. The test specimens shall be representative of the FRP gratings to be qualified including materials, construction, profile, dimensions, coatings, and so forth.

TABLE 1 Structural Fire Integrity Requirements

Location	Service	Structural Fire Integrity
Machinery spaces	Walkways or areas which may be used for escape, or access for firefighting, emergency operation, or rescue	L1 ^A
	Personnel walkways, catwalks, ladders, platforms, or access areas other than those described above	L3
Cargo pump rooms	All personnel walkways, catwalks, ladders, platforms, or access areas	L1
Cargo holds	Walkways or areas which may be used for escape, or access for firefighting, emergency operation, or rescue	L1
	Personnel walkways, catwalks, ladders, platforms, or access areas other than those described above	L0
Cargo tanks	All personnel walkways, catwalks, ladders, platforms, or access areas	L0
Fuel oil tanks	All personnel walkways, catwalks, ladders, platforms, or access areas	L0
Ballast water tanks	All personnel walkways, catwalks, ladders, platforms, or access areas	L0
Cofferdams, void spaces, double bottoms, pipe tunnels, and so forth	All personnel walkways, catwalks, ladders, platforms, or access areas	L0
Accommodation, service, and control spaces	All personnel walkways, catwalks, ladders, platforms, or access areas	Not permitted
Lifeboat embarkation or temporary safe refuge stations in open deck areas	All personnel walkways, catwalks, ladders, platforms, or access areas	L2
Open decks or semi-enclosed areas	Operational areas and access routes for deck foam firefighting systems on tank vessels	L2
	Walkways or areas that may be used for escape, or access for firefighting systems and AFFF hose reels, emergency operation, or rescue on MODUs and production platforms including safe access to tanker bows	L2
	Walkways or areas that may be used for escape or access for firefighting systems, emergency operation, or rescue other than those described above	L3
	Personnel walkways, catwalks, ladders, platforms, or access areas other than those described above	L3

^A If the machinery space does not contain any internal combustion machinery, other oil burning, oil heating, or oil pumping units, fuel oil filling stations, or other potential hydrocarbon fire sources and has not more than 5.5 lb/ft² (2.5 kg/m²) of combustible storage, gratings of L3 structural fire integrity may be used in lieu of L1.

6. Number of Tests and Retests

6.1 *General*—The number of tests are as described in the test requirements portion of this specification. If significant changes occur to the manufacturing process or material specifications that may affect the physical properties or system qualification requirements, qualification tests related to the significant change shall be required.

TEST REQUIREMENTS

7. Summary

7.1 The following test requirements shall be met: deflection limits, assembled grating ultimate failure, wheel loading, assembled panel impact resistance, skid resistance, durability, ultraviolet (UV) resistance, salt spray, surface flammability, and structural fire integrity. Testing shall be conducted by a laboratory acceptable to the AHJ.

8. Deflection Limits (Application, Not Fire)

8.1 The grating panel shall meet the following load deflection limits:

8.1.1 The specified performance requirements for each platform area shall include the qualified span (L), the uniform load (U), or the concentrated load (C), or combination thereof.

8.1.2 The minimum uniform design load of the grating shall be 150-lb/ft² (7.2 kN/m²) (safety factor included).

8.1.3 The maximum mid-span deflection of the grating panel shall not exceed 0.25 in. (0.6 cm) when tested at the qualified span.

9. Assembled Grating Ultimate Failure

9.1 The grating panel shall have a flexural strength of 50 000 psi (344 738 kPa) or greater using the three-point bending test procedure in [Appendix X5](#). The flexural strength shall be determined from an average of five test specimens that shall be cut from three different panels. Each test specimen shall be 11⁷/₈ to 13⁷/₈ in. (302 to 352 mm) in width to allow for the differences in the spacing of longitudinal load-bearing members. The width shall be measured at the top surface from outside load-bearing member to outside load-bearing member. The unsupported span of each specimen shall be equal or greater than the qualified span. Test specimens shall be cut when required using representative methods and equipment as recommended by the manufacturer.

10. Wheel Loading

10.1 The manufacturer shall supply test data showing that the proposed grating product has passed the following wheel load test:

10.1.1 A 36-in. (91-cm) wide panel shall be supported on two steel beams at the qualified span.

10.1.2 A hard rubber wheel shall be cycled over the panel. One cycle is equal to two passes.

10.1.3 The wheel shall travel 24 in. (61 cm) per pass.

10.1.4 The wheel shall have a minimum durometer hardness of 75 (Shore A).

10.1.5 The wheel shall be 6 in. (15 cm) in diameter by 2 in. (5 cm) wide.

10.1.6 The wheel travel shall be perpendicular to the bearing bars.

10.1.7 The wheel shall be positioned at the midspan of the qualified span.

10.1.8 The wheel shall make a minimum of five cycles (ten passes) per minute.

10.1.9 The wheel shall be loaded to a minimum of 1000 lbs (454 kg).

10.1.10 The loaded wheel shall be cycled 500 times (1000 passes).

10.1.11 The grating panel shall be considered to have successfully passed the wheel loading test if:

10.1.11.1 The cyclic loading produces no visual cracks in the top/bottom flanges or the webs of the bearing bars, and

10.1.11.2 The grating panel height (of the wheel contact area) shall not be worn away/reduced by more than 0.03 in. (0.8 mm).

11. Assembled Panel Impact Resistance

11.1 The manufacturer shall supply test data showing that the proposed grating product has passed the following impact test:

11.2 One continuous 11⁷/₈- to 13⁷/₈-in. (302- to 352-mm) wide panel of sufficient length shall be cut in half along its length to allow for two panel lengths to be tested to full section failure on the qualified span. These two panels shall be the control panel and the impact test panel (see [Fig. 4](#)).

11.2.1 Pultruded panels shall have the grating bars in the long direction, such that the cutting in half is perpendicular to the grating bars as shown in [Fig. 4](#).

11.2.2 There is no bearing bar alignment for molded grating.

11.3 The control panel shall be tested to failure at the qualified span in a simply supported condition to determine the flexural strength and stiffness (see [Fig. 5](#)).

11.4 The impact test panel shall be tested as follows:

11.4.1 The grating shall be tested at the qualified span (see [Fig. 5](#)).

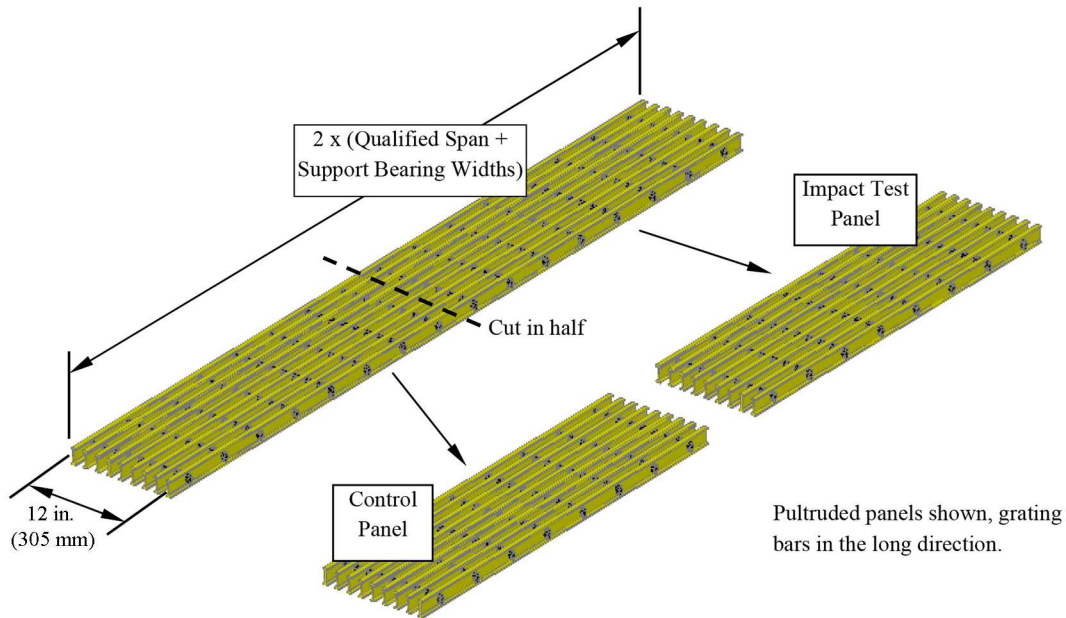

FIG. 4 How to Obtain Impact Test Panel and Control Panel

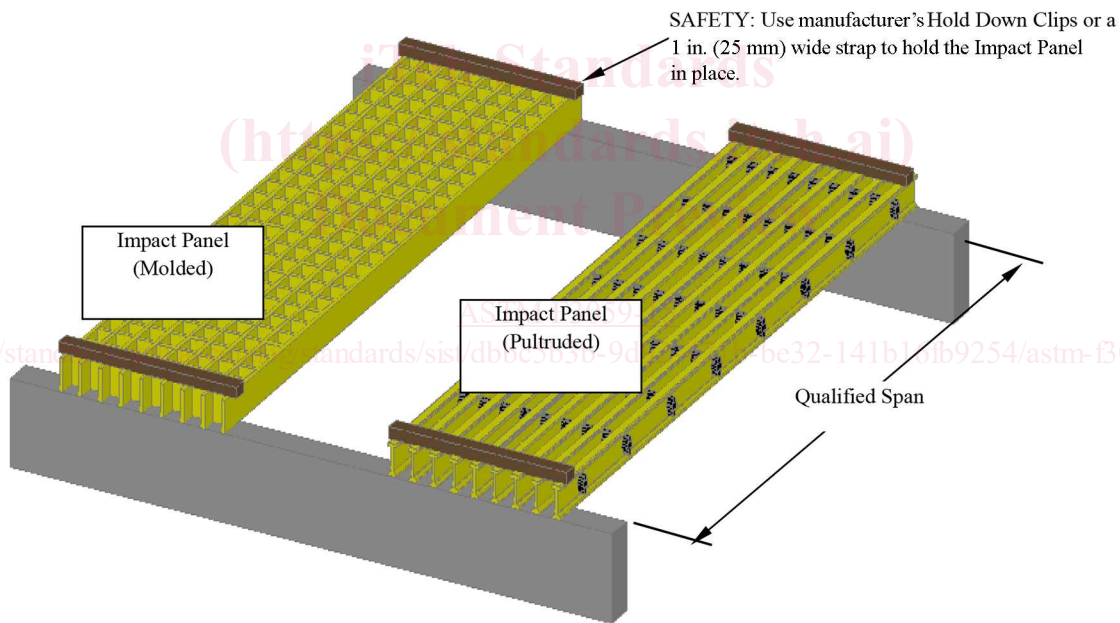

FIG. 5 Impact Panel Simply Supported at the Qualified Span

11.4.2 An impact load of 12 000 in.-lb (68 520 mm-N) of kinetic energy shall be dropped from a free fall height of no less than 36 in. (91 cm) above the grating (see Fig. 6).

11.4.2.1 The impact energy is the product of the applied load and the clear drop distance.

11.4.3 The surface that impacts the grating shall be steel, it shall directly impact the grating (that is, the grating shall not be buffered with sand bags), and it shall be allowed to bounce uninterrupted until it comes to rest by itself. The allowable impact area of 120 in.² (775 cm²) is shown in Fig. 6.

11.5 After the grating is subjected to the impact load, the impacted panel shall be tested to failure at the qualified span in a simply supported condition to determine the flexural strength and stiffness. The flexural strength and stiffness (EI at L/50) of the impact panel shall be at least 90 % of the control panel.

12. Skid Resistance (Test Method D2047)

12.1 FRP grating shall be evaluated for skid resistance in accordance with Test Method D2047 and shall have an average coefficient of friction greater than 0.75 for dry leather conditions in accordance with the referenced standard.

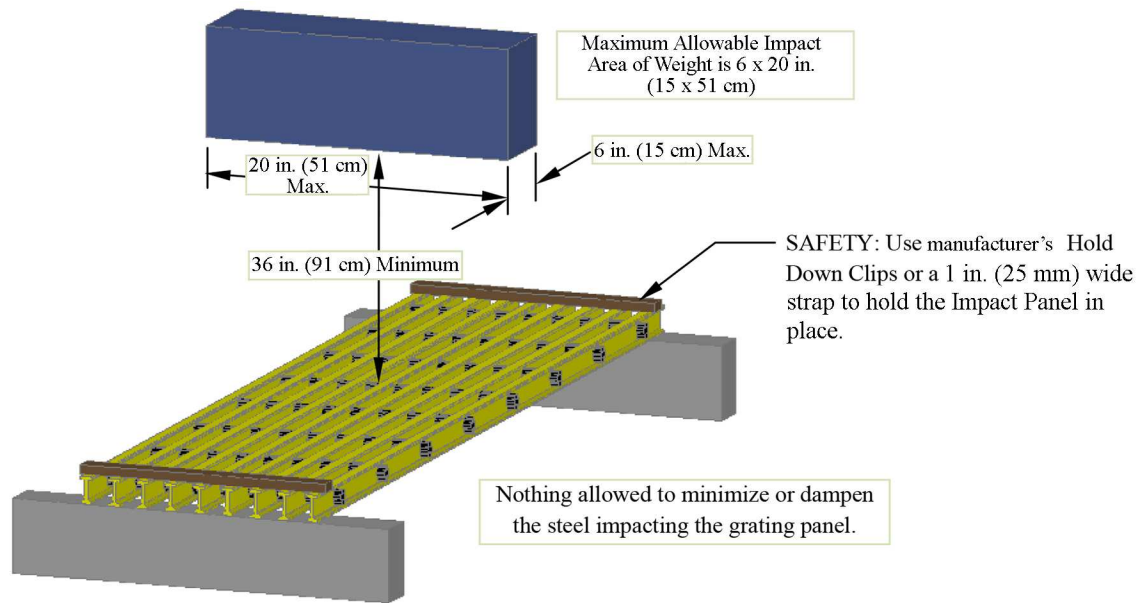

FIG. 6 Impact Load Schematic

13. Durability (Test Method D4060)

13.1 FRP gratings shall be tested for durability in accordance with Test Method D4060.

13.2 The test requires a 4-in. (10-cm) square or 4-in. (10-cm) diameter round, flat plate.

13.3 For the flat plate, the manufacturer shall use the same composite laminate as would be used in the FRP grating.

13.4 The manufacturer shall prepare two sets of samples using the same nonskid surface (grit and adhesive combination) that is intended to be applied to the FRP grating.

13.4.1 One set of samples shall be considered the “standard sample.”

13.4.2 One set of samples shall be considered the “UV sample” and shall be tested to Practice D4329 Cycle A for a minimum of 720 h.

13.5 Both the standard sample and the UV sample shall be tested to Test Method D4060 using H-22 type wheels. The number of cycles to wear through the grit to the substrate shall be at least 1200.

13.6 The manufacturer shall report the following for both the standard sample and the UV sample:

13.6.1 If tested to failure, report the number of cycles to wear through the grit to the substrate; and

13.6.2 The wear index in accordance with Test Method D4060.

14. UV Resistance (Practice D4329)

14.1 FRP gratings shall be evaluated for resistance to UV exposure when such exposure exists in service.

14.2 Subject FRP grating specimens to accelerated weathering in accordance with Test Method D4329 for a minimum period of 720 h.

14.3 After the specimens have undergone accelerated weathering, visually examine the specimens for damage.

14.4 After accelerated weathering of the FRP grating specimens, no evidence of damage including breaks, cracks, blistering, delaminating, or exposure of fibers, or combination thereof, shall be present.

15. Saltwater Spray Test

15.1 The saltwater spray test shall be conducted in accordance with Practice B117.

15.2 The specimen for the saltwater spray test shall be an assembled FRP grating panel of the dimensions of 9.1.

15.3 The salt water spray test shall be conducted for a period of seven days.

15.4 The specimen shall be load tested after salt spray exposure and shall meet the criteria for assembled grating ultimate failure in 9.1.

16. Surface Flammability

16.1 All FRP gratings shall have low flame spread characteristics determined through testing in accordance with 16.2. Test specimens shall be tested with and without any coatings (for example, UV coating, skid-resistant coating, and so forth).

16.2 *Surface Flammability in Accordance with Test Method E84:*

16.2.1 The test specimen shall be tested in accordance with Test Method E84 and as follows:

16.2.1.1 The test specimens shall be arranged with load-bearing members running the length of the Test Method E84 tunnel.

16.2.1.2 The test specimens shall be tested from both sides.

16.2.2 Acceptance criterion is a flame spread index ≤ 20 . The smoke developed index limit is ≤ 450 .

17. Structural Fire Integrity

17.1 *Test Specimens:*

17.1.1 A set of two test specimens (one preload and one postload are required for Levels 2 and 3 testing; a set of four test specimens (one preload and three postload) are required for Level 1 testing).

17.1.2 The test specimens shall be tested without any coatings (for example, UV coating, skid-resistant coating, and so forth).

17.1.3 Each test specimen shall be $11\frac{7}{8}$ to $13\frac{7}{8}$ in. (302 to 352 mm) in width to allow for the differences in the spacing of longitudinal load-bearing members. The width shall be measured at the top surface from outside load-bearing member to outside load-bearing member. The length of each test specimen shall be the maximum length to be qualified for service plus 8 in. (203 mm) but a minimum of 52 in. (1321 mm) long. Test specimens shall be cut when required using representative methods and equipment as recommended by the manufacturer.

~~17.1.4 Each test specimen shall be $11\frac{7}{8}$ to $13\frac{7}{8}$ in. (302 to 352 mm) in width to allow for the differences in the spacing of longitudinal load-bearing members. The width shall be measured at the top surface from outside load-bearing member to outside load-bearing member. The length of each test specimen shall be the maximum length to be qualified for service plus 8 in. (203 mm) but a minimum of 52 in. (1321 mm) long. Test specimens shall be cut when required using representative methods and equipment as recommended by the manufacturer.~~

17.2 *Conditioning*—Test specimens shall be conditioned for a minimum of 24 h at a temperature of $73.4 \pm 5^\circ\text{F}$ ($23 \pm 2.8^\circ\text{C}$) and at a relative humidity of $50 \pm 5\%$.

17.3 *Furnace Control:*

17.3.1 Furnace and controls shall be in accordance with Test Methods E119 unless otherwise specified in the following.

17.3.2 A minimum of eight furnace thermocouples shall be located at an elevation within 6 in. (152 mm) of the test specimen elevation. Furnace thermocouples shall be symmetrically disposed and distributed to show the temperature near all parts of the sets of test specimens without being within any flames from the test specimens.

17.4 *Support for Test Specimens*—Steel or concrete supports shall be used with a minimum support surface width of 4 in. (102 mm). The supports shall be positioned as required to establish the qualified span to be seen in service. The supports shall be perpendicular to the plane of the FRP gratings. The top bearing surface of the supports shall be as required to allow adequate FRP grating deflection for evaluation without interference of the furnace floor.

17.5 *Static Load System*—The system shall be capable of imposing a ~~4-in. (102-mm) wide~~, centrally located static load of a minimum 88 lbf (391 N) at the mid span of the test specimen and distributed evenly across the load-bearing members. This 88 lbf (391 N) load shall consist of a steel container filled with sand, the base of which shall be square with an area of 1 ft^2 (0.09 m^2).

17.6 *Deflection Monitoring System*—The system shall be capable of monitoring deflection of the preloaded test specimens continuously throughout the duration of the fire test as required to determine the time, within 6 s, at which the maximum deflection criteria is exceeded.

17.7 *Distributed Load System*—The load system shall be such that a distributed load in increments not exceeding 44 lbf (196 N) can be applied until a uniform load of 94 lbf/ft^2 (4.5 kN/m^2) is reached.

17.8 *Furnace Test Procedure:*

17.8.1 *Placement of Test Specimens:*

17.8.1.1 Place a complete set of test specimens in the furnace. More than one set may be placed in the furnace if each whole additional set can be accommodated. Individual specimens of a set shall not be tested in separate runs of the furnace.

17.8.1.2 The specimens shall have a minimum 12-in. (305-mm) clearance to the furnace walls and a minimum 24-in. (610-mm) clearance to the furnace floor or more as required ensuring maximum deflection limits can be properly evaluated.

17.8.1.3 Each specimen shall be simply supported on minimum 4-in. (102-mm) wide steel or concrete supports without any other restraint to simulate the maximum unsupported span. Place the test specimen with 4 in. (100 mm) of each end resting on the supports.

17.8.1.4 For the preload test specimen of each set, apply the 88-lbf (391-N) static load at the center of the unsupported span of the test specimen. The load shall be applied over 4 in. (102 mm) of the longitudinal span and distributed evenly across the load-bearing members.

17.8.2 *Duration of Test*—Conduct test for a furnace exposure duration of 60 min.

17.8.3 *Data Recording:*

17.8.3.1 Record the furnace temperature measurements at a maximum of 1-min intervals.

17.8.3.2 Record the time at which the vertical deflection of the preload test specimen exceeds a distance equal to the length of the unsupported span divided by 10 ($L/10$). The recorded time shall be within 6 s of the occurrence.

17.8.3.3 Record the time when each of the unloaded test specimens collapse. If the specimen does not collapse, record this information.

17.9 *Calculations*—Calculate the value $L/10$, which corresponds to the length of the unsupported span divided by 10.

17.10 *Postload Test:*

17.10.1 The specimens shall be allowed to cool to ambient conditions before the postload test.

17.10.2 Postload tests shall be conducted on the test specimens not used for the preload test in 17.8.1.4. For Levels 2 and 3 qualifications, only one test specimen of each set is required to be tested. For Level 1 qualification, each test specimen of the set shall be tested other than the preload specimen.

17.10.3 For Level 3, conduct the center load test in 17.10.4. For Level 2, consecutively conduct the center load test in 17.10.4 and the uniform load test in 17.10.5. For Level 1, consecutively conduct for each test specimen the center load test in 17.10.4, the uniform load test in 17.10.5, the impact test in 17.10.6, and again the uniform load test in 17.10.5.

17.10.4 *Center Load Test:*

17.10.4.1 Each postload test specimen shall be supported as in 17.8.1.3 and shall be subject to the 88-lbf (392-N) static load at center of the unsupported span as required in 17.8.1.4 (the preloaded test). The static load shall be applied for 15 min after the specimen appears motionless.

17.10.4.2 Record whether each test specimen sustained the load without collapse. The specimen touching the ground or falling off the supports shall be considered as a collapse.

17.10.5 *Uniform Load Test:*

17.10.5.1 Each postload test specimen shall be supported as in 17.8.1.3.

17.10.5.2 To each, apply a uniform distributed load gradually in increments not exceeding 44 lbf (196 N) until a load of 94 lbf/ft² (4.5 kN/m²) is reached or until collapse, whichever occurs first. ~~Each incremental load shall be applied for at least 5 min.~~ The final load shall be applied for 15 min after the specimen appears motionless.

17.10.5.3 Record the load resulting in collapse for each specimen. Record whether each test specimen sustained the final load without collapse. The specimen touching the ground or falling off the supports shall be considered as a collapse.

17.10.6 *Impact Test:*

17.10.6.1 Subject the test specimens to impact testing in accordance with Test Method E695.

17.10.6.2 The test specimens shall be secured as required in Test Method E695 except that the span between supports should be 8 in. (203 mm) less than the pretest specimen length.

17.10.6.3 A lead shot bag with a minimum mass of 88 lbs (40 kg) shall be dropped one time on each test specimen from a minimum height of 78¾ in. (200 cm), such that the point of impact is the midpoint of the span.

17.11 *Acceptance Criteria for Structural Fire Integrity:*

17.11.1 *Level 3 (L3)*—The FRP gratings are considered to comply with Level 3 structural fire integrity requirements if they meet the following requirements:

17.11.1.1 The time for the heat exposure for the preload test specimen exceeds 18 min,

17.11.1.2 The unloaded test specimens did not collapse during the furnace test in 17.8, and

17.11.1.3 The test specimen in 17.10.4 supported the load for the specified duration without collapse.

17.11.2 *Level 2 (L2)*—The FRP gratings are considered to comply with Level 2 structural fire integrity requirements if they meet the requirements of Level 3 structural fire integrity and the test specimen in 17.10.5 supported the load for the specified duration without collapse.

17.11.3 *Level 1 (L1)*—The FRP gratings are considered to comply with Level 1 structural fire integrity requirements if all three postload specimens meet the requirements of Level 2 structural fire integrity and withstand the impact test in accordance with 17.10.6 and subsequent uniform load test in accordance with 17.10.5 without collapse.

17.11.4 *Level 0 (L0)*—There are no structural fire integrity requirements.

18. Inspection

18.1 Inspection requirements shall be as required by the approving or certifying body.

19. Certification

19.1 Certification requirements shall be as required by the approving or certifying body.

20. Product Marking

20.1 Each FRP grating shall be marked as a minimum with the brand and the appropriate fire rating (that is, L1, L2, L3, or L0). The label shall be molded into the grating or included on a permanently attached label. If applicable, the FRP grating shall be permanently marked with the USCG approval number.