



Designation: ~~D4310~~—~~10~~ D4310 – 10 (Reapproved 2015)

## Standard Test Method for Determination of Sludging and Corrosion Tendencies of Inhibited Mineral Oils<sup>1</sup>

This standard is issued under the fixed designation D4310; the number immediately following the designation indicates the year of original adoption or, in the case of revision, the year of last revision. A number in parentheses indicates the year of last reapproval. A superscript epsilon ( $\epsilon$ ) indicates an editorial change since the last revision or reapproval.

### 1. Scope\*~~Scope~~

1.1 This test method covers and is used to evaluate the tendency of inhibited mineral oil based steam turbine lubricants and mineral oil based anti-wear hydraulic oils to corrode copper catalyst metal and to form sludge during oxidation in the presence of oxygen, water, and copper and iron metals at an elevated temperature. The test method is also used for testing circulating oils having a specific gravity less than that of water and containing rust and oxidation inhibitors.

NOTE 1—During round robin testing copper and iron in the oil, water and sludge phases were measured. However, the values for the total iron were found to be so low (that is, below ~~0.8 mg~~), 0.8 mg), that statistical analysis was inappropriate. The results of the cooperative test program are available (see Section 16).

1.2 This test method is a modification of Test Method ~~D943~~ where the oxidation stability of the same kinds of oils is determined by following the acid number of oil. The number of test hours required for the oil to reach an acid number of ~~2.0 mg~~ 2.0 mg KOH/g is the *oxidation lifetime*.

1.3 Procedure A of this test method requires the determination and report of the weight of the sludge and the total amount of copper in the oil, water, and sludge phases. Procedure B requires the sludge determination only. The acid number determination is optional for both procedures.

1.4 The values stated in SI units are to be regarded as standard. No other units of measurement are included in this standard.

1.5 **WARNING**—Mercury has been designated by many regulatory agencies as a hazardous material that can cause central nervous system, kidney and liver damage. Mercury, or its vapor, may be hazardous to health and corrosive to materials. Caution should be taken when handling mercury and mercury containing products. See the applicable product Material Safety Data Sheet (MSDS) for details and EPA's website—<http://www.epa.gov/mercury/faq.htm>—for additional information. Users should be aware that selling mercury and/or mercury containing products into your state or country may be prohibited by law.

1.6 *This standard does not purport to address all of the safety concerns, if any, associated with its use. It is the responsibility of the user of this standard to establish appropriate safety and health practices and determine the applicability of regulatory limitations prior to use.* For specific warning statements, see Section 7 and ~~X1.1.5~~.

### 2. Referenced Documents

#### 2.1 ASTM Standards:<sup>2</sup>

[A510 Specification for General Requirements for Wire Rods and Coarse Round Wire, Carbon Steel](#)

[B1 Specification for Hard-Drawn Copper Wire](#)

[D664 Test Method for Acid Number of Petroleum Products by Potentiometric Titration](#)

[D874 Test Method for Sulfated Ash from Lubricating Oils and Additives](#)

[D943 Test Method for Oxidation Characteristics of Inhibited Mineral Oils](#)

[D1193 Specification for Reagent Water](#)

[D3339 Test Method for Acid Number of Petroleum Products by Semi-Micro Color Indicator Titration](#)

[D4057 Practice for Manual Sampling of Petroleum and Petroleum Products](#)

[E1 Specification for ASTM Liquid-in-Glass Thermometers](#)

<sup>1</sup> This test method is under the jurisdiction of ASTM Committee [D02](#) on Petroleum Products, Liquid Fuels, and Lubricants and is the direct responsibility of Subcommittee [D02.09.0C](#) on Oxidation of Turbine Oils.

Current edition approved ~~July 1, 2010~~ Oct. 1, 2015. Published ~~July 2010~~ December 2015. Originally approved in 1983. Last previous edition approved in ~~2009~~ 2010 as ~~D4310~~ [D4310 – 10](#), ~~09~~; DOI: ~~10.1520/D4310-10~~ [10.1520/D4310-10R15](#).

<sup>2</sup> For referenced ASTM standards, visit the ASTM website, [www.astm.org](http://www.astm.org), or contact ASTM Customer Service at [service@astm.org](mailto:service@astm.org). For *Annual Book of ASTM Standards* volume information, refer to the standard's Document Summary page on the ASTM website.

\*A Summary of Changes section appears at the end of this standard

2.2 *Energy Institute Standard*:<sup>3</sup>

Specification for IP Standard Thermometers

2.3 *British Standard*:<sup>4</sup>

BS 1829 Reference Tables for Iron v. Constantan Thermocouples

### 3. Terminology

3.1 *Definitions*:

3.1.1 *sludge*—a precipitate or sediment from oxidized mineral oil and water.

### 4. Summary of Test Method

4.1 An oil sample is contacted with oxygen in the presence of water and an iron-copper catalyst at ~~95°C~~95 °C for ~~1000 h~~1000 h. The weight of insoluble material is determined gravimetrically by filtration of the oxidation tube contents through ~~5-µm~~5 µm pore size filter disks. The total amount of copper in the oil, water, and sludge phases is also determined for Procedure A. Procedure B requires the sludge determination. The copper determination is not required. The acid number determination is optional for both procedures.

NOTE 2—Optionally, some operators may choose to: (1) assess the change in weight of the catalyst coil, or (2) determine the acid number at ~~1000 h~~1000 h, or both. The acid number may serve as a criterion to determine if measurement of insoluble material is warranted. Normally, further testing is not recommended on a highly oxidized oil (that is an oil which has attained an acid number ~~>2.0 mg~~>2.0 mg KOH/g). Instructions for these optional tests are not included in this test method.

### 5. Significance and Use

5.1 Insoluble material may form in oils that are subjected to oxidizing conditions.

5.2 Significant formation of oil insolubles or metal corrosion products, or both, during this test may indicate that the oil will form insolubles or corrode metals, or both, during field service. However, no correlation with field service has been established.

### 6. Apparatus

6.1 *Oxidation Cell*, of borosilicate glass, as shown in Fig. 1, consisting of a test tube, condenser, and oxygen delivery tube. The test tube has a calibration line at ~~300 mL~~300 mL (maximum error ~~1 mL~~1 mL). This calibration applies to the test tube without inserts at ~~20°C~~20 °C.

6.2 *Heating Bath: Liquid Bath or Metal Block*, thermostatically controlled, capable of maintaining the oil sample in the oxidation cell at a temperature of ~~95~~95 °C ± 0.2°C, fitted with a suitable stirring device to provide a uniform temperature throughout the bath, and large enough to hold the desired number of oxidation cells immersed in the heating bath to a depth of ~~390~~390 mm ± 10 mm and in the heating liquid itself to a depth of ~~355~~355 mm ± 10 mm.

6.2.1 Studies have suggested that direct sunlight or artificial light may adversely influence the results of this test.<sup>5</sup> To minimize effects of light exposure on the lubricant being tested, light shall be excluded from the lubricant by one or more of the following ways:

6.2.1.1 Use of heated liquid baths that are designed and constructed of metal, or combinations of metals and other suitable opaque materials, that prevent light from entering the test cell from the sides is preferred. If a *viewing window* is included in the design, this *viewing window* shall be fitted with a suitable opaque cover and be kept closed when no observation is being made.

6.2.1.2 If glass heating baths are used, the bath shall be wrapped with aluminum foil or other opaque material.

6.2.1.3 Bright light entering the test cell from directly overhead can be eliminated by use of an opaque shield.

6.3 *Flowmeter*, with a flow capacity of at least ~~3 L~~3 L of oxygen/hour, and an accuracy of ~~±0.1 L/h~~±0.1 L/h.

6.4 *Heating Bath Thermometer*—ASTM Solvents Distillation Thermometer having a range from ~~72~~72 °C to 126°C and conforming to the requirements for Thermometer 40C as prescribed in Specification E1, or for Thermometer 70C as prescribed in Specifications for IP Standard Thermometers. Alternatively, temperature-measuring devices of equal or better accuracy may be used.

6.5 *Oxidation Cell Thermometer*, having a range from ~~80~~80 °C to ~~100°C~~100 °C, graduated in ~~0.1°C~~0.1 °C, total length—~~250 mm~~length—250 mm, stem diameter—~~6.0~~diameter—6.0 mm to ~~7.0 mm~~7.0 mm, calibrated for ~~76 mm~~76 mm immersion. Temperature measuring devices such as liquid-in-glass thermometers, thermocouples, or platinum resistance thermometers that provide equivalent or better accuracy and precision that cover the temperature range, may be used.

6.6 *Wire Coiling Mandrel*, as shown in Fig. 2.

<sup>3</sup> Available from Energy Institute, 61 New Cavendish St., London W1M 8AR, England-London, W1G 7AR, U.K., <http://www.energyinst.org>.

<sup>4</sup> Available from British Standards Institution (BSI), 389 Chiswick High Rd., London W4 4AL, U.K.-U.K., <http://www.bsigroup.com>.

<sup>5</sup> Supporting data (summary of the results of these studies) have been filed at ASTM International Headquarters and may be obtained by requesting Research Report RR:D02-1365.

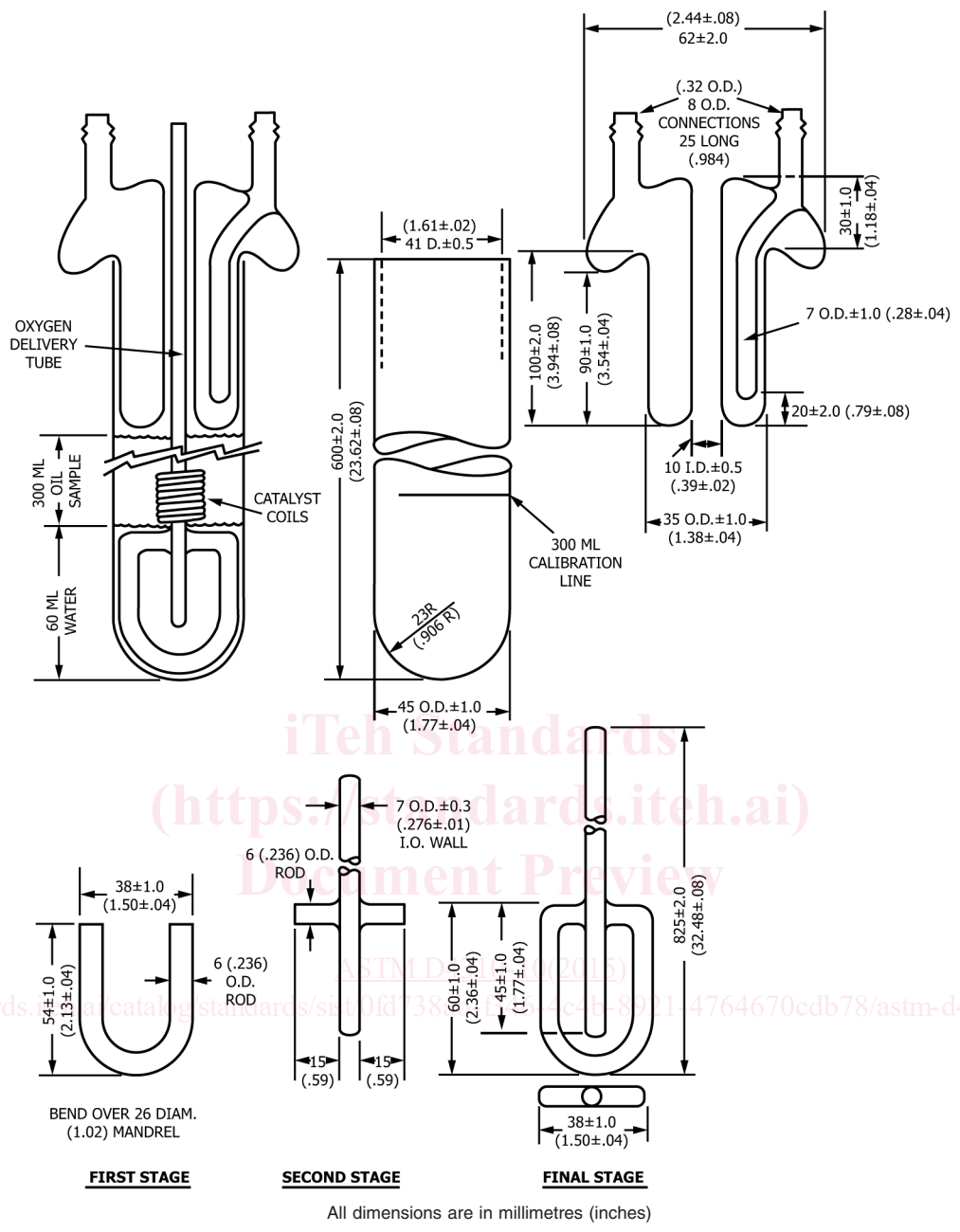

NOTE 1—The oxidation test tube has a calibration line at 300 mL. This calibration applies to the test tube alone at 20°C ± 20 °C.  
 NOTE 2—Open tube ends to be ground and fire-polished.

FIG. 1 Oxidation Cell

6.7 *Thermometer Bracket*, for holding the oxidation cell thermometer, of 18-8 stainless steel, having the dimensions shown in Fig. 3. The thermometer is held in the bracket by two fluoro-elastomer O-rings of approximately 5-mm (5 mm) inside diameter. Alternatively, thin stainless steel wire may be used.

6.8 *Abrasive Cloth*, silicon carbide, 100-grit with cloth backing.

6.9 *Flexible Tubing*, poly vinyl chloride approximately 6.4-mm (6.4 mm (1/4-in.)) inside diameter with a 3/32-in. wall for delivery of oxygen to the oxidation cell.

6.10 *Membrane Filters*,<sup>6,7</sup> white, plain, 4747 mm or 90-mm (90 mm) in diameter, pore size 5-µm (5 µm).

<sup>6</sup> If you are aware of alternative suppliers, please provide this information to ASTM International Headquarters. Your comments will receive careful consideration at a meeting of the responsible technical committee,<sup>1</sup> which you may attend.

<sup>7</sup> The sole source of cellulose esters) known Bedford, MA.

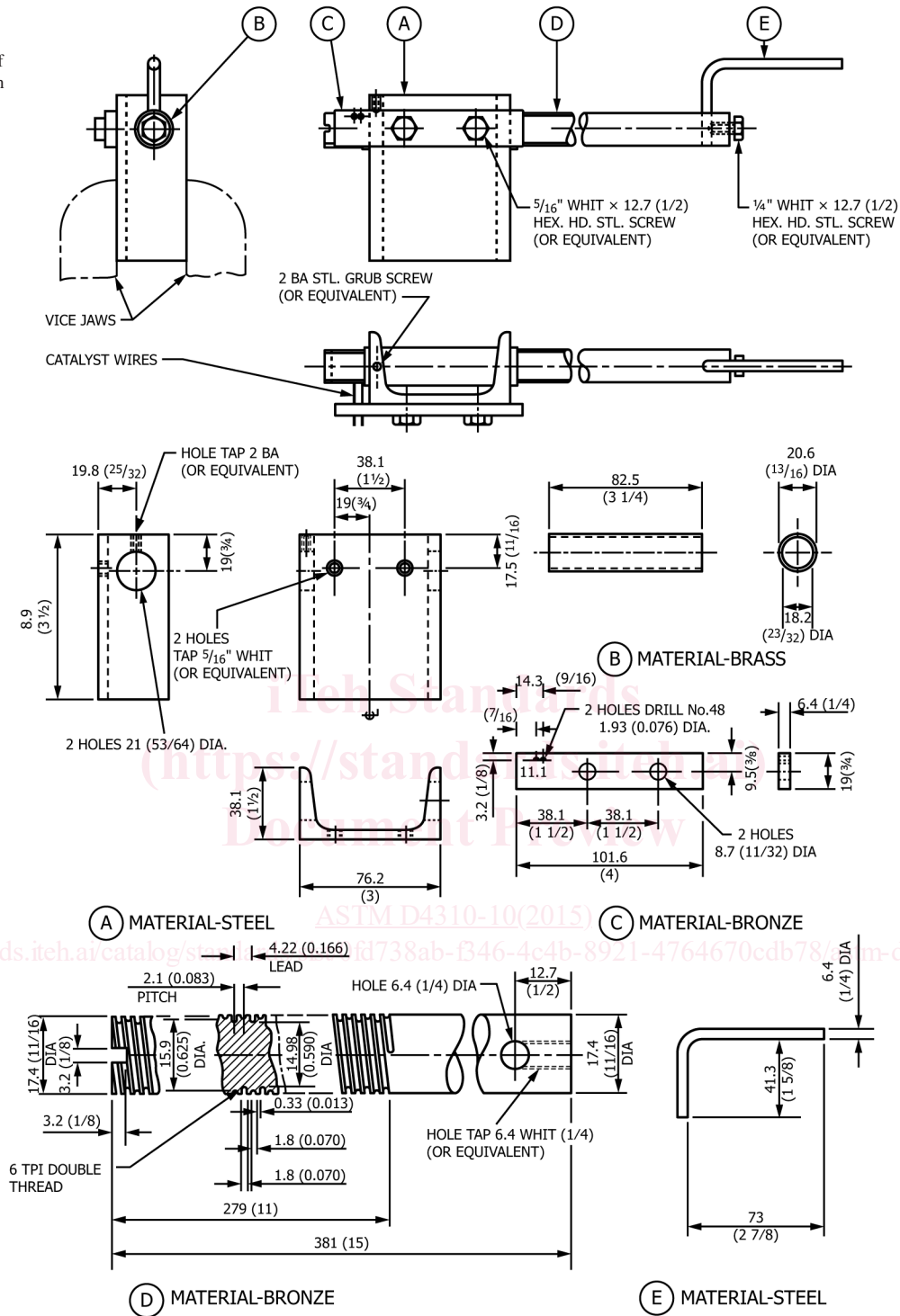

Dimensions are in millimetres (inches).  
**FIG. 2 Mandrel for Winding Catalyst Coils**

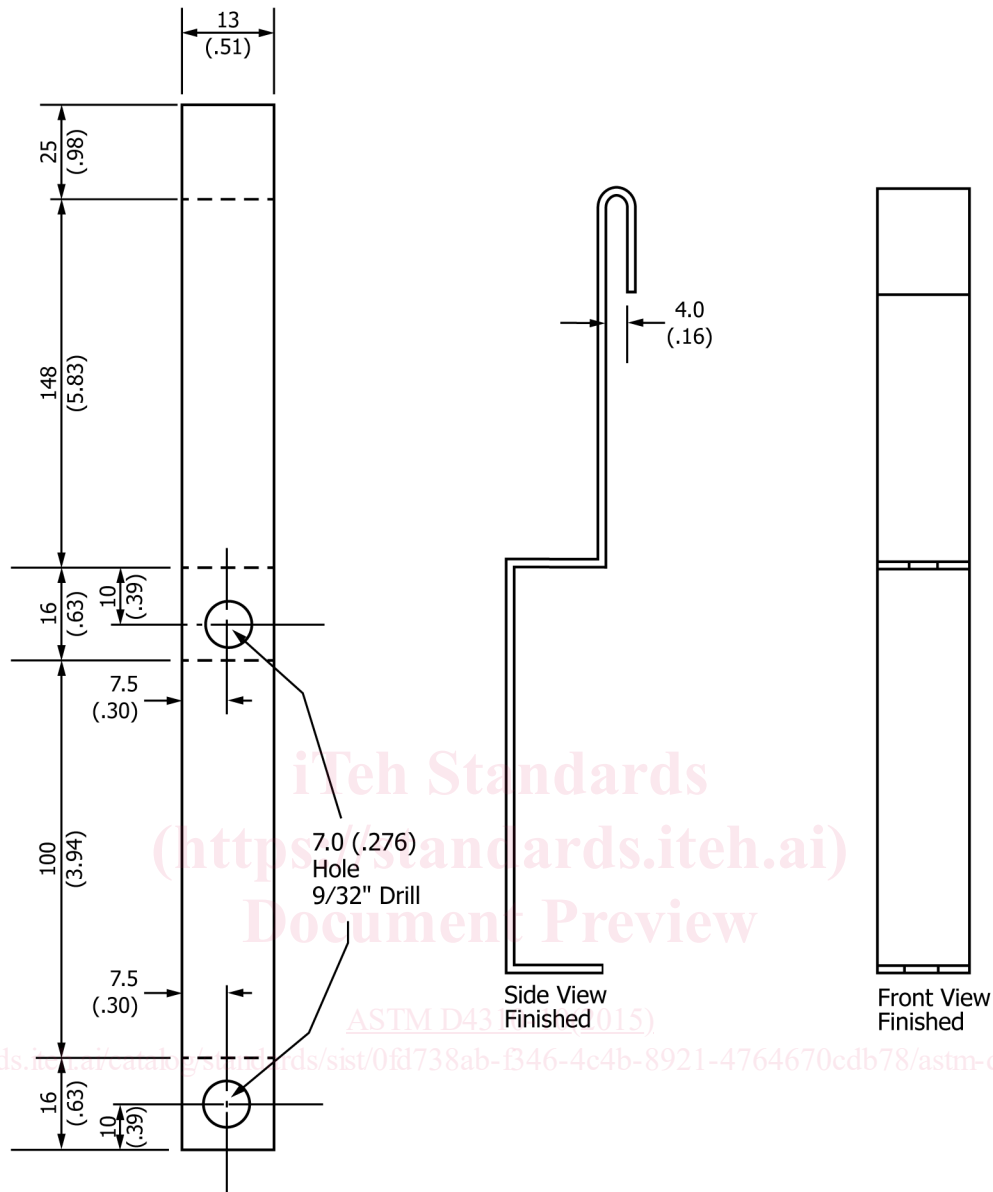

All dimensions are in millimetres (inches).  
 Material: 18-8 Stainless Steel. 22 Gauge (0.792 mm) (0.792 mm).

FIG. 3 Thermometer Bracket

6.11 *Filter Holder*, <sup>6,8</sup> 47.47 mm or 90 mm, 90 mm, consisting of a borosilicate glass funnel and a funnel base with a coarse grade (40 (40 μm) to 60 μm) (60 μm) fritted-glass filter support or stainless steel screen support such that the filter can be clamped between the ground-glass sealing surfaces of the funnel and its base by means of a metal clamp.

6.12 *Weighing Bottle*, <sup>6,9</sup> cylindrical body with ground-glass stopper; approximate inside diameter 45 mm, 45 mm, height of body 65 mm, capacity 60 mL, 65 mm, capacity 60 mL.

6.13 *Vacuum Source*, to provide pressure reduction to  $13.3 \pm 0.7$  kPa (100 ± 5 mm Hg)  $13.3 \text{ kPa} \pm 0.7 \text{ kPa}$  (100 mm ± 5 mm Hg) absolute pressure.

6.14 *Cooling Vessel*—A desiccator or other type of tightly covered vessel for cooling the weighing vessels before weighing. The use of a drying agent is not recommended.

<sup>8</sup> The sole source of supply of the Millipore Pyrex XX-10-047-00 or XX-10-047-30 filter holder known to the committee at this time is Millipore Filter Corp., Bedford, MA.

<sup>9</sup> The sole source of supply of the Fisher 3-415 weighing bottle, size G, known to the committee at this time is Fisher Scientific Co., Pittsburgh, PA.

6.15 *Drying Oven*, capable of maintaining a temperature of ~~±05~~105 °C ± ~~2~~2 °C.

6.16 *Forceps*, having unserrated tips.

6.17 *Syringe*, ~~50-mL~~50 mL Luer-Lok with ~~42-in.~~12 in. needle.

6.18 *Separatory Funnels*, with a capacity of ~~1000 mL~~1000 mL.

6.19 *Rubber Policeman*.

6.20 *Pipette Bulb*.

6.21 *Syringe*, glass or plastic, with Luer-Lok locking connector, ~~10-mL~~10 mL capacity for sampling.

6.22 *Syringe Sampling Tube*, Grade 304 stainless steel tubing, ~~2.11 mm (0.083 in.)~~ outside diameter, ~~1.60 mm (0.063 in.)~~ inside diameter, ~~559 ± 2 mm (24.0 ± 0.08 in.)~~ 2.11 mm (0.083 in.) outside diameter, 1.60 mm (0.063 in.) inside diameter, 559 mm ± 2 mm (24.0 in. ± 0.08 in.) long, with one end finished at 90° and the other end fitted with a Luer-Lok female connector.

**iTeh Standards**  
**(<https://standards.iteh.ai>)**  
**Document Preview**

[ASTM D4310-10\(2015\)](#)

<https://standards.iteh.ai/catalog/standards/sist/0fd738ab-f346-4c4b-8921-4764670cdb78/astm-d4310-102015>