



Designation: ~~D7667 – 10~~^{e2} D7667 – 10 (Reapproved 2015)

Standard Test Method for Determination of Corrosiveness to Silver by Automotive Spark-Ignition Engine Fuel—Thin Silver Strip Method¹

This standard is issued under the fixed designation D7667; the number immediately following the designation indicates the year of original adoption or, in the case of revision, the year of last revision. A number in parentheses indicates the year of last reapproval. A superscript epsilon (ϵ) indicates an editorial change since the last revision or reapproval.

^{e1} NOTE—Added legend to Fig. 1 editorially in July 2012.

^{e2} NOTE—Subsection 7.4 was revised editorially in March 2014.

1. Scope

1.1 This test method covers the determination of the corrosiveness to silver by automotive spark-ignition engine fuel (for example, gasoline), as defined by Specification **D4814** or similar specifications in other jurisdictions, having a vapor pressure no greater than 124 kPa (18 psi) at 37.8°C (100°F) ~~124 kPa (18 psi) at 37.8 °C (100 °F)~~ by one of two procedures.

1.1.1 *Procedure A*—Involves the use of a pressure vessel.

1.1.2 *Procedure B*—Involves the use of a vented test tube.

1.2 The values stated in SI units are to be regarded as the standard. The values in parentheses are for information only.

1.3 **WARNING**—Mercury has been designated by many regulatory agencies as a hazardous material that can cause central nervous system, kidney and liver damage. Mercury, or its vapor, may be hazardous to health and corrosive to materials. Caution should be taken when handling mercury and mercury containing products. See the applicable product Material Safety Data Sheet (MSDS) for details and EPA's website—<http://www.epa.gov/mercury/faq.htm>—for additional information. Users should be aware that selling mercury and/or mercury containing products into your state or country may be prohibited by law.

1.4 *This standard does not purport to address all of the safety concerns, if any, associated with its use. It is the responsibility of the user of this standard to establish appropriate safety and health practices and determine the applicability of regulatory limitations prior to use.*

2. Referenced Documents

2.1 *ASTM Standards:*²

D130 Test Method for Corrosiveness to Copper from Petroleum Products by Copper Strip Test

D3241 Test Method for Thermal Oxidation Stability of Aviation Turbine Fuels

D4057 Practice for Manual Sampling of Petroleum and Petroleum Products

D4177 Practice for Automatic Sampling of Petroleum and Petroleum Products

D4814 Specification for Automotive Spark-Ignition Engine Fuel

E1 Specification for ASTM Liquid-in-Glass Thermometers

2.2 *Energy Institute Standards:*³

IP 227 Determination of Corrosiveness to Silver of Aviation Turbine Fuels - Silver Strip Method

2.3 *ASTM Adjuncts:*⁴

Color standard for tube deposit rating (5 aluminum strips)

3. Terminology

3.1 *Abbreviations:*

¹ This test method is under the jurisdiction of ASTM Committee **D02** on Petroleum Products, Liquid Fuels, and Lubricants and is the direct responsibility of Subcommittee **D02.05.0C** on Color and Reactivity.

Current edition approved Oct. 1, 2010. Published December 2010. Originally approved in 2010. Last previous edition approved in 2010 as **D7667 – 10**². DOI: 10.1520/D7667-10E02:10.1520/D7667-10R15.

² For referenced ASTM standards, visit the ASTM website, www.astm.org, or contact ASTM Customer Service at service@astm.org. For *Annual Book of ASTM Standards* volume information, refer to the standard's Document Summary page on the ASTM website.

³ Available from Energy Institute, 61 New Cavendish St., London, WIG 7AR, U.K., <http://www.energyinst.org.uk>.

⁴ Available from ASTM International Headquarters. Order Adjunct No. **ADJD3241**. Original adjunct produced in 1986.

- PTFE = polytetrafluoroethylene
- PV = pressure vessel
- PVP = pressure vessel procedure
- SSCD = silver strip centering device
- TSMD = temperature sensing and monitoring device
- VTPP = vented test tube procedure

4. Summary of Test Method

4.1 A polished, thin silver strip is immersed in ~~30 mL~~ 30 mL of the sample being tested, and heated at ~~50°C (122°F) for 2 h.~~ 50 °C (122 °F) for 2 h. At the end of the heating period, the silver strip is removed, washed, and the color and tarnish level assessed against the Silver Strip Classifications in [Table 1](#).

5. Significance and Use

5.1 Crude petroleum contains sulfur compounds, most of which are removed during refining. However, of the sulfur compounds remaining in the petroleum product or introduced into the fuel during storage and distribution, some can have a corroding action on various metals and this corrosivity is not necessarily related directly to the total sulfur content. The effect can vary according to the chemical types of sulfur compounds present. The silver strip corrosion test is designed to assess the relative degree of corrosivity of a petroleum product towards silver and silver alloys.

5.2 Under some circumstances, reactive sulfur compounds present in automotive spark-ignition engine fuels can tarnish or even corrode silver alloy fuel gauge in-tank sender units or silver-plated bearings (in 2-stroke cycle engines). To minimize or prevent the failure of silver alloy in-tank sender units by tarnish or corrosion, Specification [D4814](#) requires that fuels shall pass a silver strip corrosion test.

6. Apparatus

6.1 *Silver Strip Corrosion Pressure Vessel (Procedure A)*, constructed from stainless steel according to dimensions given in [Fig. 1](#), as described in Test Method [D130](#). The vessel shall be capable of withstanding a test pressure of ~~700 kPa (100 psi)~~ 700 kPa (100 psi). Alternative designs for the vessel’s cap and synthetic rubber gasket may be used provided that the internal dimensions of the vessel are the same as shown in [Fig. 1](#), which allow a nominal ~~25 by 150 mm (1 by 6 in.)~~ 25 mm by 150 mm (1 in. by 6 in.) test tube (see [6.2](#)) and the SSCD (see [6.4](#)) to be placed inside the pressure vessel.

6.2 *Test Tubes*, of borosilicate glass of nominal ~~2525 mm~~ 2525 mm by 150 mm (~~±(1 in. by 6 in.)~~ ±6 in.) dimensions, preferably graduated at ~~30 mL~~ 30 mL volume.^{5,6} The internal dimensions shall be checked as acceptable by use of a silver strip (see [7.4](#)). When ~~30 mL~~ 30 mL of sample is added to the test tube with the silver strip in it, a minimum of 5 mm of liquid shall be above the top surface of the strip.

6.3 *Test Bath, General*, whether liquid or solid, the test bath shall be able to maintain the test temperature to within $\pm 1^{\circ}\text{C}$ ($\pm 2^{\circ}\text{F}$) $\pm 1^{\circ}\text{C}$ ($\pm 2^{\circ}\text{F}$) of the required test temperature. It is recommended that baths be placed inside a fume-hood.

6.3.1 *Bath*, shall be fitted with suitable supports to hold each test tube (see [6.2](#)) in a vertical position to a depth of about 100 mm (~~4 in.~~ 4 in.) as measured from the bottom of the test tube to the bath surface.

6.3.2 *Bath Medium*, as a liquid bath medium, both water and oil have been found to be satisfactory and controllable at the specified test temperature and duration required by the test procedure.

6.3.3 *Solid Block Bath*, made of aluminum, shall meet the test temperature control, test duration, and immersion conditions required by the test procedure, and shall be verified, at least annually, for temperature measurement (heat transfer) by running tests on tubes filled with ~~30 mL~~ 30 mL of product plus a thin silver strip of the given nominal dimensions, plus a temperature sensor.

⁵ The sole source of supply of the apparatus known to the committee at this time is Quark Enterprises, Inc., 320 Morton Ave., Rosenhayn, NJ 08352.

⁶ If you are aware of alternative suppliers, please provide this information to ASTM International Headquarters. Your comments will receive careful consideration at a meeting of the responsible technical committee,¹ which you may attend.

TABLE 1 Silver Strip Classifications

NOTE 1—Acknowledgement—This table has been reproduced from Standard IP 227.

Classification	Designation	Description
0	No Tarnish	Identical to a freshly-polished strip but may have some very slight loss of luster
1	Slight Tarnish	Faint brown or white discoloration of strip (see 12.2)
2	Moderate Tarnish	Peacock colors such as blue or mauve or medium/dark straw or brown coloration (see 12.2)
3	Slight blackening	Spots and patches of black or gray on surface or uniform thin film of black deposit
4	Blackening	Uniform heavy blackening with or without scaling

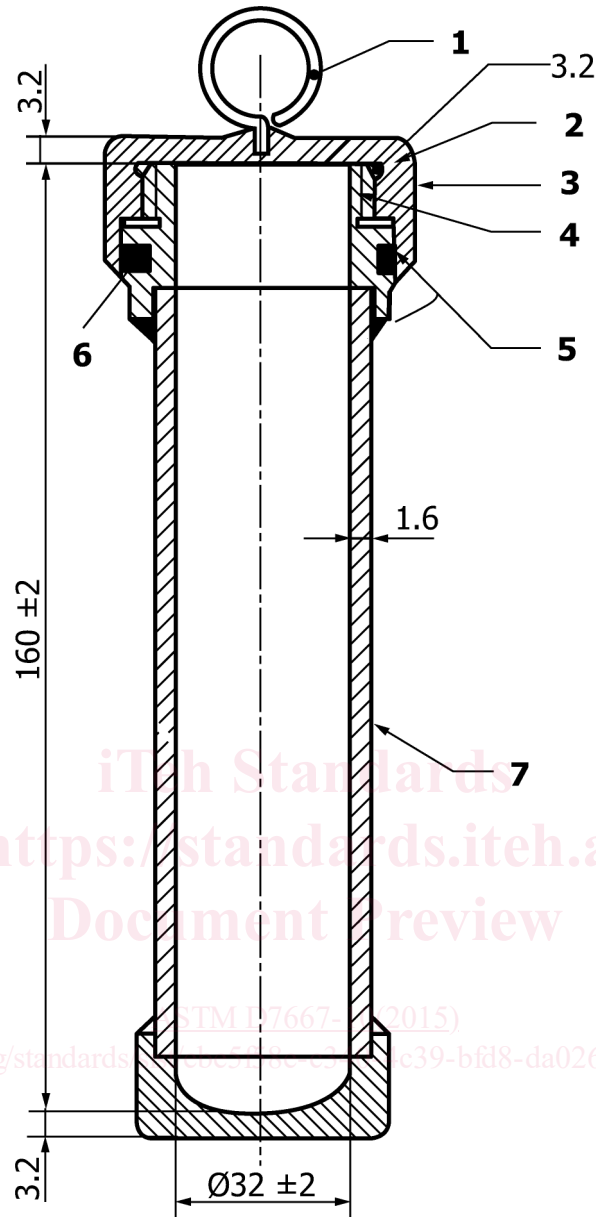

Key:

1. Lifting eye
2. Wide groove for pressure relief
3. Knurled cap
4. Twelve threads per inch NF thread or equivalent
5. Camber inside cap to protect "O" ring when closing pressure vessel
6. Synthetic rubber "O" ring without free sulfur
7. Seamless tube

Material: stainless steel

Welded construction

Maximum test gauge pressure: 700 kPa

NOTE 1—Dimensions in millimetres.

NOTE 2—All dimensions without tolerance limits are nominal values.

FIG. 1 Pressure Vessel for Silver Strip Corrosion Test – Procedure A

6.3.3.1 Wells provided in the solid block bath to accommodate pressure vessels (see Fig. 1) shall be of the following dimensions: ~54 mm~54 mm (2 1/8 in.) diameter from top, up to a depth of ~70 mm~70 mm (2 3/4 in.) continuing with an opening of ~38 mm~38 mm (1 1/2 in.) diameter up to a depth of ~140 mm~140 mm (5 1/2 in.). An opening of ~8 mm~8 mm (5/16

~~in.)~~ diameter by ~~210 mm~~ 210 mm (8¼ in.) depth shall be provided in the center of the block for immersion of a metal temperature sensor (connected to a suitable ~~50~~ 50 °C ± 1 °C (~~122~~ 122 °F ± 2 °F) temperature controller), or thermometer (see 6.5).

6.3.3.2 Wells provided in the solid block bath to accommodate test tubes shall be of the following dimensions: ~~20 mm~~ 20 mm (1⅙ in.) diameter by ~~140 mm~~ 140 mm (5½ in.) deep. An opening of ~~8 mm~~ 8 mm (5/16 in.) diameter by ~~210 mm~~ 210 mm (8¼ in.) depth shall be provided in the center of the block for immersion of a metal temperature sensor (connected to a suitable ~~50~~ 50 °C ± 1 °C (~~122~~ 122 °F ± 2 °F) temperature controller), or thermometer (see 6.5).

6.3.3.3 Provide insulation made of ~~25.4 mm~~ 25.4 mm (1.0 in.) thick fiberglass with aluminum backing (or, similar insulation) to cover all the four sides of the solid block bath.

6.4 *Silver Strip Centering Device (SSCD)*,^{7,6} made of material which is gasoline-compatible at ~~50°C~~ 50 °C (122 °F) for the duration of the test, such as Acetal Resin, White Nylon 6/6, or PTFE. See details in **A1.1** (Assembly View) and **A1.2** (Individual Parts View). Length of SSCD inside the test tube is such that the lower edge of the assembled silver strip is about ~~22 mm~~ 22 mm (7/8 in.) from the bottom of the test tube.

6.5 *Temperature Sensing and Monitoring Device (TSMD)*, capable of sensing and monitoring the desired test temperature in the bath to within an accuracy of ~~±1°C~~ ±1 °C (2 °F). The ASTM 12C (12F) (see Specification **E1**) or IP 64C (64F) total immersion thermometer has been found suitable for use in the test. If used, no more than ~~10 mm~~ 10 mm (0.4 in.) of the mercury shall extend above the surface of the bath at the test temperature.

6.6 *Timing Device*, electronic or manual, capable of accurately measuring the test duration within the allowable tolerance.

6.7 *Forceps*, with inert tips, stainless steel or polytetrafluoroethylene (PTFE) tips, have been found suitable for use in handling the silver strips.

6.8 *Polishing Board*, ~~150 mm~~ 150 mm by ~~100 by 3 mm~~ 100 mm by 3 mm (6 in. by 4 in. by 1/8 in.) solid plastic piece having a smooth surface, for placement of silver strip during polishing.

6.9 *Optional Equipment:*

6.9.1 *Refrigerator*, for cooling samples below ~~5°C~~ 5 °C (41 °F) during storage.

7. Reagents and Materials

7.1 *Wash Solvent*, 2,2,4-trimethylpentane (iso-octane) of minimum 99.75 % purity. (**Warning**—Extremely flammable, see 8.1.)

7.2 *Surface Preparation/Polishing Material*, Scouring-pad, approximately ~~400-grit~~ 400 grit, made of polyester material that is free of detergents or spongy material, containing aluminum oxide as a scouring-aid.^{8,6}

NOTE 1—Some 400-grit pads are commercially available in the form of ~~229 mm~~ 229 mm by ~~152 by 9.5 mm~~ 152 mm by 9.5 mm (9 in. by 6 in. by 3/8 in.) thick pads. For ease of handling and polishing, it is recommended that the pads be cut so that the dimensions of the scouring-pads are about ~~114 mm~~ 114 mm by ~~38 mm~~ 38 mm by ~~9.5 mm~~ 9.5 mm (4½ in. by 1½ in. by 3/8 in.).

7.3 *Waterproof Aluminum Oxide Cloth Sanding Sheets or Rolls*,^{9,6} 150-grit.

7.4 *Silver Strips*, Use strips ~~36.0 mm~~ 36.0 mm to 40.0 mm (1⅙ in. to 1⅙ in.) long, ~~6.25 mm~~ 6.25 mm to 6.35 mm (1/4 in. to 1/4 in.) wide and ~~0.526 mm~~ 0.526 mm to ~~0.541 mm~~ 0.541 mm (~1.35/64 in.) thick, assaying at 99.9 % (m/m) Ag minimum.^{10,6} When necessary, cut, straight and smooth, using a sharp tin-snip or any other metal-cutting device, (such as a heavy-duty ~~152 mm~~ 152 mm (6 in.) shear^{11,6}) approximately ~~38.0 mm~~ 38.0 mm (1½ in.) long strips from the longer strips supplied. Strips may be used repeatedly, but should be discarded when the original shape becomes deformed, or surface shows pitting, scratches or tarnish that cannot be removed by the specified polishing procedure.

7.5 *Ashless Filter Paper or Disposable Gloves or Finger-Tip Protectors*, for use in protecting the silver strip from coming in contact with the individual during polishing.

8. Hazards

8.1 *Wash Solvent*. (**Warning**— iso-octane: Harmful if inhaled. Vapors may cause flash fire. Keep away from heat, sparks and open flames, and container closed. Use with adequate ventilation. Avoid build-up of vapors and eliminate all sources of ignition, especially non-explosion-proof electrical apparatus and heaters. Avoid prolonged breathing of vapor or spray mist.)

8.2 *Gasoline, (Unleaded or Leaded)*. (**Warning**—Keep away from heat, sparks and open flames, and container closed. Use with adequate ventilation. Avoid build-up of vapors and eliminate all sources of ignition, especially non-explosion-proof electrical apparatus and heaters. Avoid prolonged breathing of vapor or spray mist. Avoid prolonged or repeated skin contact.)

⁷ The sole source of supply of the apparatus known to the committee at this time is K & C Manufacturing, 210 S. Main, Newkirk, OK 74647.

⁸ The sole source of supply of the apparatus known to the committee at this time is 3M's "Scotch Brite 86" scouring pads (~~114 mm~~ 114 mm by ~~38 mm~~ 38 mm by ~~9.5 mm~~ 9.5 mm thick cut pieces) were used in the ruggedness study.

⁹ The sole source of supply of the apparatus known to the committee at this time is Part No. 8225A22 (1½ width roll), McMaster Carr Supply Co.

¹⁰ The sole source of supply of the apparatus known to the committee at this time is pre-cut silver strips, C&P Catalyst, PO Box 520984, Tulsa, OK 74152.

¹¹ The sole source of supply of the apparatus known to the committee at this time is Part No. 82818, Micro-mark, 340 Snyder Ave., Berkeley Heights, NJ 07922.