



Designation: **D5708 – 12^{ε1}** **D5708 – 15**

Standard Test Methods for Determination of Nickel, Vanadium, and Iron in Crude Oils and Residual Fuels by Inductively Coupled Plasma (ICP) Atomic Emission Spectrometry¹

This standard is issued under the fixed designation D5708; the number immediately following the designation indicates the year of original adoption or, in the case of revision, the year of last revision. A number in parentheses indicates the year of last reappraisal. A superscript epsilon (ϵ) indicates an editorial change since the last revision or reappraisal.

^{ε1} NOTE—Subsection ~~X1.5~~ was corrected editorially in May 2015.

1. Scope*

1.1 These test methods cover the determination of nickel, vanadium, and iron in crude oils and residual fuels by inductively coupled plasma (ICP) atomic emission spectrometry. Two different test methods are presented.

1.2 *Test Method A (Sections 7 – 11 and 18 – 22)*—ICP is used to analyze a sample dissolved in an organic solvent. This test method uses oil-soluble metals for calibration and does not purport to quantitatively determine or detect insoluble particulates.

1.3 *Test Method B (Sections 12 – 22)*—ICP is used to analyze a sample that is decomposed with acid.

1.4 The concentration ranges covered by these test methods are determined by the sensitivity of the instruments, the amount of sample taken for analysis, and the dilution volume. A specific statement is given in 15.2. Typically, the low concentration limits are a few tenths of a ~~mg/kg~~ milligram per kilogram. Precision data are provided for the concentration ranges specified in Section 21.

1.5 The values stated in SI units are to be regarded as standard. ~~The values given in parentheses are for information only.~~

1.5.1 *Exception*—~~The values given in parentheses are for information only.~~

1.6 *This standard does not purport to address all of the safety concerns, if any, associated with its use. It is the responsibility of the user of this standard to establish appropriate safety and health practices and determine the applicability of regulatory limitations prior to use.*

2. Referenced Documents

2.1 *ASTM Standards:*²

[D1193 Specification for Reagent Water](#)

[D1548 Test Method for Vanadium in Heavy Fuel Oil¹ \(Withdrawn 1997\)³](#)

[D4057 Practice for Manual Sampling of Petroleum and Petroleum Products](#)

[D4177 Practice for Automatic Sampling of Petroleum and Petroleum Products](#)

[D5185 Test Method for Multielement Determination of Used and Unused Lubricating Oils and Base Oils by Inductively Coupled Plasma Atomic Emission Spectrometry \(ICP-AES\)](#)

[D6299 Practice for Applying Statistical Quality Assurance and Control Charting Techniques to Evaluate Analytical Measurement System Performance](#)

[D7260 Practice for Optimization, Calibration, and Validation of Inductively Coupled Plasma-Atomic Emission Spectrometry \(ICP-AES\) for Elemental Analysis of Petroleum Products and Lubricants](#)

3. Summary of Test Method

3.1 *Test Method A*—Approximately ~~10 g~~ 10 g of the sample are dissolved in an organic solvent (**Warning**—Combustible. Vapor is harmful.) to give a specimen solution containing 10 % (m/m) of sample. The solution is nebulized into the plasma, and the

¹ These test methods are under the jurisdiction of ASTM Committee D02 on Petroleum Products, Liquid Fuels, and Lubricants and is the direct responsibility of Subcommittee D02.03 on Elemental Analysis.

Current edition approved Dec. 1, 2012/Dec. 1, 2015. Published January 2013/December 2015. Originally approved in 1995. Last previous edition approved in 2011/2012 as ~~D5708D5708 – 12^{ε1}~~ D5708 – 15. DOI: ~~10.1520/D5708-12E01~~ 10.1520/D5708-15.

² For referenced ASTM standards, visit the ASTM website, www.astm.org, or contact ASTM Customer Service at service@astm.org. For *Annual Book of ASTM Standards* volume information, refer to the standard's Document Summary page on the ASTM website.

³ The last approved version of this historical standard is referenced on www.astm.org.

*A Summary of Changes section appears at the end of this standard

intensities of the emitted light at wavelengths characteristic of the analytes are measured sequentially or simultaneously. The intensities are related to concentrations by the appropriate use of calibration data.

3.2 *Test Method B*—One to ~~20 g~~ 20 g of sample are weighed into a beaker and decomposed with concentrated sulfuric acid (**Warning**—Poison. Causes severe burns. Harmful or fatal if swallowed or inhaled.) by heating to dryness. Great care must be used in this decomposition because the acid fumes are corrosive and the mixture is potentially flammable. The residual carbon is burned off by heating at ~~525°C~~ 525 °C in a muffle furnace. The inorganic residue is digested with nitric acid (**Warning**—Poison. Causes severe burns. Harmful or fatal if swallowed or inhaled.), evaporated to incipient dryness, dissolved in dilute nitric acid, and made up to volume. The solution is nebulized into the plasma of an atomic emission spectrometer. The intensities of light emitted at characteristic wavelengths of the metals are measured sequentially or simultaneously. These intensities are related to concentrations by the appropriate use of calibration data.

4. Significance and Use

4.1 These test methods cover, in single procedures, the determination of Ni, V, and Fe in crude oils and residual oils. These test methods complement Test Method **D1548**, which covers only the determination of vanadium.

4.2 When fuels are combusted, vanadium present in the fuel can form corrosive compounds. The value of crude oils can be determined, in part, by the concentrations of nickel, vanadium, and iron. Nickel and vanadium, present at trace levels in petroleum fractions, can deactivate catalysts during processing. These test methods provide a means of determining the concentrations of nickel, vanadium, and iron.

5. Purity of Reagents

5.1 Reagent grade chemicals shall be used in all tests. Unless otherwise indicated, it is intended that all reagents conform to the specifications of the Committee on Analytical Reagents of the American Chemical Society where such specifications are available.⁴ Other grades may be used, provided it is first ascertained that the reagent is of sufficiently high purity to permit its use without lessening the accuracy of the determination.

5.2 When determining metals at concentrations less than 1 mg/kg, use ultra-pure reagents.

5.3 *Purity of Water*—Unless otherwise indicated, reference to water shall be understood to mean reagent water conforming to Type II of Specification **D1193**.

6. Sampling and Sample Handling

6.1 The objective of sampling is to obtain a sample for testing purposes that is representative of the entire quantity. Thus, take samples in accordance with the instructions in Practice **D4057** or **D4177**. Do not fill the sample container more than two-thirds full.

6.2 Prior to weighing, stir the sample and manually shake the sample container. If the sample does not readily flow at room temperature, heat the sample in a drying oven at 80°C or at another safe temperature.

TEST METHOD A— ICP WITH AN ORGANIC SOLVENT SPECIMEN SOLUTION

7. Apparatus

7.1 *Inductively Coupled Plasma Atomic Emission Spectrometer*—Either a sequential or simultaneous spectrometer, equipped with a quartz torch and radio-frequency generator to form and sustain the plasma, is suitable.

7.2 *Nebulizer*—The use of a *high-solids* nebulizer is optional but strongly recommended. This type of nebulizer minimizes the probability of clogging. A concentric glass nebulizer can also be used.

7.3 *Peristaltic Pump*—This pump is required for non-aspirating nebulizers and optional for aspirating nebulizers. The pump must achieve a flow rate in the range of ~~0.50.5 mL/min~~ to ~~33 mL/min~~ 0.50 mL/min to 33 mL/min. The pump tubing must be able to withstand at least a ~~6 h~~ 6 h exposure to the solvent. Fluoroelastomer copolymer tubing is recommended.⁵

7.4 *Specimen Solution Containers*, glass or plastic vials or bottles with screw caps having a capacity of appropriate size. One hundred millilitre glass bottles are satisfactory.

⁴ *Reagent Chemicals, American Chemical Society Specifications*, American Chemical Society, Washington, DC. For Suggestions on the testing of reagents not listed by the American Chemical Society, see *Annual Standards for Laboratory Chemicals*, BDH Ltd., Poole, Dorset, U.K., and the *United States Pharmacopeia and National Formulary*, U.S. Pharmacopeial Convention, Inc. (USPC), Rockville, MD.

⁵ Fluoroelastomer copolymer is manufactured as Viton, a trademark owned by E. I. duPont de Nemours.

8. Reagents

8.1 *Dilution Solvent*—Mixed xylenes, *o*-xylene, tetralin and mixed paraffin-aromatic solvents are satisfactory. Solvent purity can affect analytical accuracy when the sample contains low concentrations (typically, a few ~~mg/kg~~ milligrams per kilogram) of the analytes.

8.2 *Mineral Oil*—A high-purity oil such as U.S.P. white oil.

8.3 *Organometallic Standards*—Pre-prepared multielement concentrates containing ~~100 mg/kg~~ 100 mg/kg concentrations of each element are satisfactory.

8.4 *Quality Control (QC) Samples*, preferably are portions of one or more liquid petroleum materials that are stable and representative of the samples of interest. These QC samples can be used to check the validity of the testing process as described in Section 19.

9. Preparation of Standards and Specimens

9.1 *Blank*—Prepare a blank by diluting mineral oil with dilution solvent. The concentration of mineral oil must be 10 % (m/m). Mix well.

9.2 *Check Standard*—Using organometallic standards, mineral oil, and dilution solvent, prepare a check standard to contain analyte concentrations approximately the same as expected in the specimens. The concentration of oil in the check standard must be 10 % (m/m).

9.3 *Test Specimen*—Weigh a portion of well-mixed sample into a container and add sufficient solvent to achieve a sample concentration of 10 % (m/m). Mix well.

9.4 *Working Standard*—Prepare an instrument calibration standard that contains ~~10 mg/kg~~ 10 mg/kg each of vanadium, nickel, and iron. Combine the organometallic standard, dilution solvent and, if necessary, mineral oil so that the oil content of the calibration standard is 10 % (m/m).

9.5 *Quality Control (QC) Samples*—Weigh a portion of the well-mixed QC sample into a container and add sufficient solvent to achieve a sample concentration of 10 % (m/m).

10. Preparation of Apparatus

10.1 Consult Practice **D7260** regarding the optimum operation of any ICP-AES system.

10.2 Consult the manufacturer's instructions for the operation of the ICP instrument. This test method assumes that good operating procedures are followed. Design differences between instruments make it impractical to specify required parameters.

10.3 Assign the appropriate operating parameters to the instrument taskfile so that the desired analytes can be determined. Parameters include: (1) element, (2) analytical wavelength, (3) background correction wavelengths (optional), (4) interelement correction factors (refer to 10.4), (5) integration time of 1 to 10 s, (6) two to five consecutive repeat integrations. Suggested wavelengths are listed in **Table 1**.

10.4 *Spectral Interferences*—Check all spectral interferences expected for the analytes. If interference corrections are necessary, follow the manufacturer's operating guide to develop and apply correction factors.

10.4.1 Spectral interferences can usually be avoided by judicious choice of analytical wavelengths. If spectral interferences cannot be avoided, the necessary corrections should be made using the computer software supplied by the instrument manufacturer or by using the empirical method described in Test Method **D5185**.

10.5 Consult the instrument manufacturer's instructions for operating the instrument with organic solvents.

10.6 During instrument warm-up, nebulize the blank solution. Inspect the torch for carbon build-up. When carbon build-up occurs, replace the torch and adjust the operating conditions to correct the problem.

TABLE 1 Elements Determined and Suggested Wavelengths

NOTE 1—These wavelengths are suggestions and do not represent all possible choices.^A

Element	Wavelength, nm
Iron	259.94, 238.20
Nickel	231.60, 216.56
Vanadium	292.40, 310.22

^A Winge, R. K., Fassel, V. A., Peterson, V. J., and Floyd, M. A., *Inductively Coupled Plasma Atomic Emission Spectroscopy: An Atlas of Spectral Information*, Elsevier, NY, 1985.

10.6.1 Carbon build-up within the torch can be caused by improperly adjusted argon flow rates, improper solution flow rates, and positioning the torch injector tube too close to the load coil. Carbon deposits can invalidate a calibration and extinguish the plasma.

11. Calibration and Analysis

11.1 Using the blank and working standard, perform a two-point calibration at the beginning of the analysis of each batch of specimens. Additional working standards can be used, if desired.

11.2 Use the check standard to determine if the calibration for each analyte is accurate. When the result obtained on the check standard is not within $\pm 5\%$ of the expected concentration for each analyte, take corrective action and repeat the calibration.

11.3 Analyze the specimens in the same manner as the calibration standards (that is, same integration time, plasma conditions, and so forth). Calculate concentrations by multiplying the concentration determined for the test specimen solution by the dilution factor. Calculation of concentrations can be performed manually or by computer when such a feature is available.

11.4 When the measured intensities for the test specimen solution exceed the corresponding intensities for the working standard, either ensure that the calibration curve is linear to the concentration of the element in the test specimen solution or dilute the test specimen solution with the blank solution and reanalyze.

11.5 Analyze the check standard after every fifth specimen. If any result is not within 5% of the expected concentration, take corrective action, repeat the calibration, and reanalyze the specimen solutions back to the previous acceptable check standard analysis.

11.6 The use of spectral background correction is highly recommended, particularly when the test specimen solutions contain low concentrations of the analytes (typically less than 1 mg/kg). When concentrations are low, background changes, which can result from variability in the compositions of test specimen solutions, can affect the accuracy of the analysis. Background correction minimizes errors due to variable background intensities.

TEST METHOD B— ICP AFTER ACID DECOMPOSITION OF SAMPLE

12. Apparatus

12.1 Refer to 7.1 – 7.4.

12.2 *Sample Decomposition Apparatus (optional)*—This apparatus is shown in Fig. 1. It consists of a high-silica or borosilicate ~~400-mL~~400 mL beaker for the specimen, an air bath (Fig. 2) that rests on a hot plate, and a ~~250-watt~~250 watt infrared lamp supported ~~1-in.~~1 in. above the air bath. A variable transformer controls the voltage applied to the lamp.

12.3 *Glassware*, high-silica or borosilicate ~~400-mL~~400 mL beakers, volumetric flasks of various capacities, and pipettes of various capacities. ~~When determining concentrations below 1 mg/kg, all glassware~~ All glassware used in this test method must be thoroughly cleaned and rinsed with water.

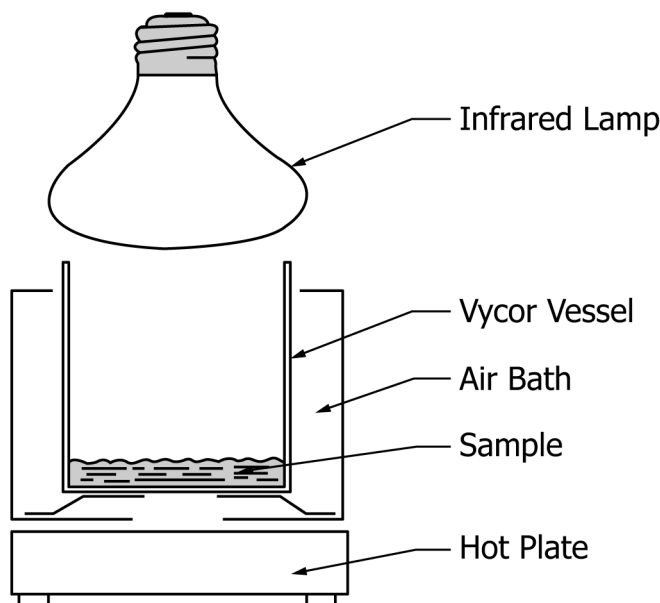
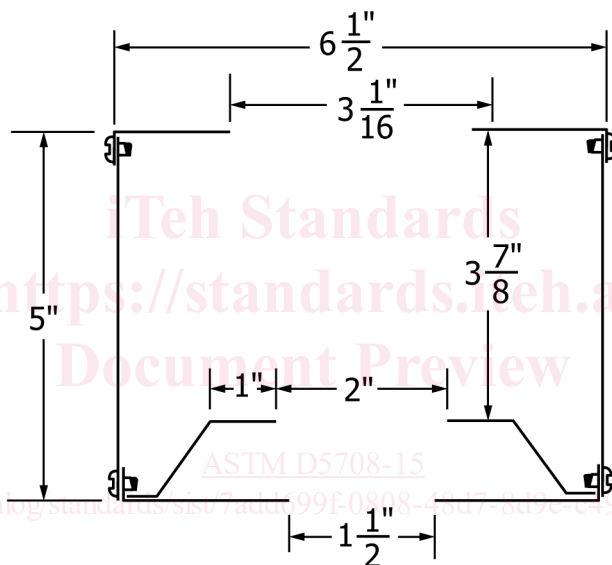
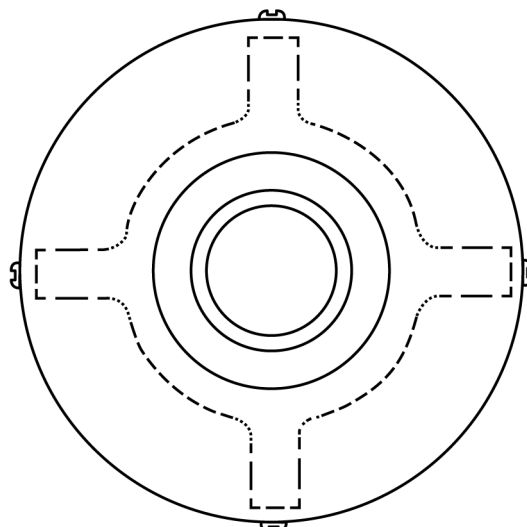

FIG. 1 Decomposition Apparatus



NOTE 1—All parts are 16-gauge (0.060 in., 1.5 mm) (0.060 in., 1.5 mm) aluminum. All dimensions are in inches.

		Metric Equivalents	
in.		mm	
1		25.4	3 ⁷ / ₈
1 ¹ / ₂		38.1	5
2		50.8	6 ¹ / ₂
3 ¹ / ₁₆		77.8	

FIG. 2 Air Bath

12.4 *Electric Muffle Furnace*, capable of maintaining 525 ± 25 °C and sufficiently large to accommodate 400-mL beakers. The capability of an oxygen bleed is advantageous and optional.

12.5 *Steam Bath (optional)*.

12.6 *Temperature Controlled Hot Plate (optional)*.

13. Reagents

13.1 *Aqueous Standard Solutions*, individual aqueous standards with 1000 mg/L concentrations of vanadium, nickel, and iron.

13.2 *Nitric Acid*, concentrated nitric acid, HNO₃.

13.3 *Nitric Acid (1 + 1)*—Carefully add, with stirring, one volume of concentrated nitric acid to one volume of water.

13.4 *Dilute Nitric Acid (19 + 1)*—Carefully add, with stirring, one volume of concentrated nitric acid to 19 volumes of water.

13.5 *Sulfuric Acid*, concentrated sulfuric acid, H₂SO₄.

14. Preparation of Standards and Quality Control (QC) Samples

14.1 *Blank Standard*—Dilute (19 + 1) nitric acid.

14.2 *Multi-element Standard*—Using the aqueous standard solutions, prepare a multi-element standard containing ~~100~~100 mg/~~1 L~~ each of vanadium, nickel, and iron.

14.3 *Working Standard*—Dilute the multi-element standard ten-fold with dilute nitric acid.

14.4 *Check Standards*—Prepare calibration check standards in the same way as the working standard and at analyte concentrations that are typical of the samples being analyzed.

14.5 *Quality Control (QC) Samples*—Follow Section 15 using the QC samples as test specimens.

15. Preparation of Test Specimens

15.1 Into a beaker, weigh an amount of sample estimated to contain between ~~0.0025~~0.0025 mg and ~~0.12 mg~~0.12 mg of each metal to be determined. A typical mass is ~~10 g~~. Add ~~0.5 mL~~10 g. Add 0.5 mL of H₂SO₄ for each gram of sample.

NOTE 1—If it is desirable to extend the lower concentration limits of the method, it is recommended that the decompositions be done in ~~10 g~~10 g increments up to a maximum of ~~100 g~~100 g. It is not necessary to destroy all the organic matter each time before adding additional amounts of sample and acid. When it is desirable to determine higher concentrations, reduce the sample size accordingly.

15.2 At the same time, prepare reagent blanks using the same amount of sulfuric acid as used for sample decomposition. Perform all steps specified in this section. (**Warning**—Reagent blanks are critical when determining concentrations below ~~1 mg/kg~~1 mg/kg. To simplify the analysis, use the same volume of acid and the same dilutions as used for the samples. For example, if ~~20 g~~20 g of sample is being decomposed, use ~~10 mL~~10 mL of sulfuric acid for the reagent blank.)

15.3 The use of the air bath apparatus (Fig. 2) to minimize sample spattering and foaming is optional. Place the beaker in the air bath, which is located in a hood. The hot plate is off at this time. Heat gently from the top with the infrared lamp (Fig. 1) while stirring the specimen with a glass rod. As decomposition proceeds (indicated by a frothing and foaming), control the heat of the infrared lamp to maintain steady evolution of fumes. Give constant attention to each sample mixture until all risk of spattering and foaming is past. Then, gradually increase the temperatures of both the hot plate and lamp until the sample is reduced to a carbonaceous ash.

15.4 If the air bath apparatus is not used, heat the sample and acid on a temperature controlled hot plate. As described in 15.3, monitor the decomposition reaction and adjust the temperature of the hot plate accordingly. (**Warning**—Hot, fuming, concentrated sulfuric acid is a very strong oxidizing acid. The analyst should work in a well-ventilated hood and wear rubber gloves and a suitable face shield to protect against spattering acid.)

15.5 Place the sample in a muffle furnace maintained at ~~525~~525 °C ± 25°C:25 °C. Optionally, introduce a gentle stream of oxygen into the furnace to expedite oxidation. Continue to heat until the carbon is completely removed.

15.6 Dissolve the inorganic residue by washing down the wall of the beaker with about ~~10 mL~~10 mL of 1 + 1 HNO₃. Digest on a steam bath for 15 to 30 min. Transfer to a hot plate and gently evaporate to incipient dryness.

15.7 Wash down the wall of the beaker with about ~~10 mL~~10 mL of dilute nitric acid. Digest on the steam bath until all salts are dissolved. Allow to cool. Transfer quantitatively to a volumetric flask of suitable volume and make up to volume with dilute nitric acid. This is the specimen solution.

16. Preparation of Apparatus

16.1 Refer to 10.2 – 10.4.

17. Calibration and Analysis

17.1 Refer to Section 11.

TABLE 2 Repeatability

NOTE 1—X = mean concentration, mg/kg.

Element	Concentration Range, mg/kg	Test Method	Repeatability, mg/kg
Vanadium	50–500	A	0.07X ^{0.88}
		B	0.02X ^{1.1}
Nickel	10–100	A	0.01X ^{1.3}
		B	0.02X ^{1.2}
Iron	1–10	A	0.22X ^{0.30}
		B	0.23X ^{0.67}