



Designation: ~~C1710~~—~~11~~ C1710 – 15

Standard Guide for Installation of Flexible Closed Cell Preformed Insulation in Tube and Sheet Form¹

This standard is issued under the fixed designation C1710; the number immediately following the designation indicates the year of original adoption or, in the case of revision, the year of last revision. A number in parentheses indicates the year of last reapproval. A superscript epsilon (ϵ) indicates an editorial change since the last revision or reapproval.

1. Scope

1.1 This guide covers recommended installation techniques for flexible closed cell pre-formed insulation in tube or sheet form. This guide is applicable to materials manufactured in accordance with Specification **C534** (Elastomeric based insulation) or Specification **C1427** (polyolefin based insulation). The materials covered in this guide encompass a service temperature of -297°F to 300°F (-183°C to 150 °C) as indicated in the material specifications referenced above. Many of the recommendations made are specific to below ambient applications only.

1.2 The purpose of this guide is to optimize the thermal performance and longevity of installed closed cell flexible insulation systems. By following this guide, the owner, and designer can expect to achieve the energy savings expected and prevention of condensation under the specified design conditions. This document is limited to installation procedures and does not encompass system design.

1.3 The values stated in inch-pound units are to be regarded as standard. The values given in parentheses are mathematical conversions to SI units that are provided for information only and are not considered standard.

1.4 *This standard does not purport to address all of the safety concerns, if any, associated with its use. It is the responsibility of the user of this standard to establish appropriate safety and health practices and determine the applicability of regulatory limitations prior to use.*

2. Referenced Documents

2.1 ASTM Standards:²

C168 Terminology Relating to Thermal Insulation

C534 Specification for Preformed Flexible Elastomeric Cellular Thermal Insulation in Sheet and Tubular Form

C585 Practice for Inner and Outer Diameters of Thermal Insulation for Nominal Sizes of Pipe and Tubing

C1427 Specification for Extruded Preformed Flexible Cellular Polyolefin Thermal Insulation in Sheet and Tubular Form

2.2 Other Standards:

National Commercial, Industrial Insulation Standards (MICA Manual)³

ASHRAE Handbook (Fundamentals – Chapter 26)⁴

ASHRAE Handbook (Refrigeration – Chapter 33)⁴

3. Terminology

3.1 *Definitions*—**C168** shall be considered as applying to the terms in this specification.

3.2 *Definitions of Terms Specific to This Standard:*

3.2.1 *seams*—Longitudinal or horizontal cross-sections where insulation meets and must be adhered to itself or other system components.

3.2.2 *butt joints*—Cross-sections where two pieces of tubular or sheet insulation must be adhered to itself or other system components.

¹ This guide is under the jurisdiction of ASTM Committee **C16** on Thermal Insulation and is the direct responsibility of Subcommittee **C16.40** on Insulation Systems. Current edition approved Sept. 1, 2011; Sept. 15, 2015. Published October 2011; December 2015. Originally approved in 2009. Last previous edition approved in 2009 as C1710-09. DOI:10.1520/C1710-11. DOI:10.1520/C1710-15.

² For referenced ASTM standards, visit the ASTM website, www.astm.org, or contact ASTM Customer Service at service@astm.org. For *Annual Book of ASTM Standards* volume information, refer to the standard's Document Summary page on the ASTM website.

³ Available from MICA (Midwest Insulation Contractors Association) 16712 Elm Circle, Omaha, NE 68130. <http://www.micainsulation.org>.

⁴ Available from American Society of Heating, Refrigerating, and Air-Conditioning Engineers, Inc. (ASHRAE), 1791 Tullie Circle, NE, Atlanta, GA 30329, <http://www.ashrae.org>.

3.2.3 *vapor (water) stops*—Locations / methods to prevent water or water vapor from traveling ~~into or down a tubular pipe section from one pipe insulation section to an adjacent insulation and prevent water traveling down the annular space between the pipe insulation and the tubular pipe.~~

3.2.4 *sleeving/multi layering*—Applying another layer of insulation over the first layer. This process is used when the insulation thickness required is greater than that which is commercially available. This technique is also employed when proper installation practice requires multiple layers and or staggered joint application, even if a single layer thickness is available.

4. Summary of Guide

4.1 Proper insulation thickness shall be installed as specified and not compromised. The integrity of the insulation system shall be maintained throughout the application. Never pull or stretch insulation, always push or over-size insulation.

4.2 All seams, butt joints, cutouts and termination points shall be sealed with a manufacturer's approved adhesive to prevent air/moisture intrusion. For below ambient applications, install vapor stops at all insulation terminations or interruptions, such as at supports, valves and flanges ~~by This can be accomplished by several methods; by adhering the insulation directly to the pipe using a 2 in. (50 mm) strip of contact adhesive or sealant to maintain closure. Insulation closure, insulation tape can also be used for this purpose by wrapping it around the pipe.~~ A vapor barrier mastic or tape can also be used for this purpose. On straight runs, install vapor stops every 18 ft (5.4 m) to minimize moisture problems if they occur.

4.3 Specific product Manufacturer's recommended installation practices shall be used in all cases.

4.4 Product should be applied to clean, dry surfaces. If the system is operating, additional steps may be needed to insure a proper installation.

4.5 A coating, jacket, cladding or appropriate protection shall be used where mechanical abuse or damage is expected. Outdoor applications may require special consideration – refer to the manufacturer's recommendations.

4.6 For satisfactory performance, properly installed protective vapor retarders/barriers and vapor stops must be used on high relative humidity and below ambient temperature applications to reduce movement of moisture through or around the insulation to the colder interior surface.

5. Significance and Use

5.1 This guide applies to flexible closed cell insulation tubing and sheet materials manufactured according to Specification **C534** and Specification **C1427**. This standard is intended to provide a basic guide for installing these types of materials.

5.2 Confirm application use temperature is consistent with specified use temperature for material as defined in ASTM Specifications unless otherwise agreed upon with the manufacturer. There are different grades for each of the insulation types referred to in this guide, material and grade installed should be that specified.

5.3 This guide is not intended to cover all aspects associated with installation for all applications, consult the National, Commercial Industrial Insulation Standards (MICA Manual) or the specific product manufacturer for recommendations, or both. (See ASHRAE Handbook (Fundamentals – Chapter 26) and ASHRAE Handbook (Refrigeration – Chapter 33)

6. Workmanship, Finish and Appearance

6.1 The insulation shall have no visible defects that will adversely affect its performance or appearance. Materials shall be kept clean and dry until used. Use good quality tools at all times. Ensure cleanliness of insulation products, pipe work, vessels, fittings and tools. Avoid dust, dirt, oil or water on surfaces and equipment. It is recommended to apply insulation to a system which is not in operation. If insulation must be applied to a system that is operating, special precautions must be taken to prevent condensation from being trapped in the insulation envelope. Never stretch insulation to fit. Specified dimensions for the inner diameter (ID) and wall thickness shall be adhered to.

7. Dimensional Tolerances

7.1 Dimensions for the ID, wall and length shall conform to tolerances published by the manufacturer and or applicable ASTM standards, for example Specifications **C534**, **C1427** and Practice **C585**. can be used to determine the outer diameter of the insulation for sizing jacketing and fitting dimensions.

8. General Installation Recommendations

8.1 All seams, butt joints, cut outs and termination points should be sealed with a manufacturer's approved system. External taping of seams is not recommended as an exclusive method of sealing joints or seams for below ambient systems. Approved adhesives can be: contact adhesives, spray adhesives or pressure sensitive adhesives. Water based adhesives are not recommended because of their slow drying time which causes them to pull apart. Adhesives should be applied according to manufacturer's recommendations. A thinner layer of adhesive is best, with 100% coverage on both surfaces. Always keep adhesives stirred thoroughly. Allow solvents to dissipate before combining two surfaces. This will be determined by time, temperature and adhesive type. Ensure all seams are aligned, tight, and are completely sealed.

8.2 The specified insulation thickness should be maintained throughout the installation. When using unslit tubular insulation on pipe work being installed, the insulation should be slid/pushed on the pipe, never pulled as this will stretch and thin the insulation. The insulation is not to be stretched to fit. All insulation should be installed under slight compression to ensure a snug fit. Accommodations need to be made to prevent the insulation from being compressed by weight; that is, pipe hangers. For applications where the pipe work is already installed, the insulation must be slit and adhesive applied or pre-slit/pre-glued insulation used.

8.3 Install insulation on systems that are dry, at room temperature and already pressure tested.

8.4 Use miter boxes or templates for making accurate cuts. See Fig. 1. Keep to correct dimensions. Do not cut the insulation short and stretch it to fit the space.

8.5 Slide insulation on straight piping runs whenever possible to reduce seams. If insulation must be slit to apply to piping, slit in a straight line. On large ID insulation where the material may be oval shaped, slit along the flat side (top or bottom) not along the edge for a better fitting seam. Refer to 8.2.

9. Hazards

9.1 Use good quality tools and keep working area and materials clean. Keep cutting tools sharp. Recommend non-serrated edged steel knife which can be sharpened.

9.2 Use appropriate protective equipment, that is. Safety glasses and safe practices when installing the material.

9.3 Provide suitable ventilation when working with solvent based adhesives.

10. Recommendations for Specific Installation Situations

10.1 *Straight Pipe Section – unjoined*—Slide insulation along the pipe work for straight runs. Seal all butt joints, cut outs and termination points. See Fig. 2.

10.1.1 Slit tube in a straight line (Fig. 3). Apply a thin brush coat of contact adhesive to each seam. Slip the insulation over the pipe. Allow adhesive to properly set and press seams together at each end – working toward the center. Seal all butt joints, cut outs and termination points with adhesive.

10.1.2 Use pre-slit/pre-glued insulation. (Insulation pre-slit with factory applied pressure sensitive adhesive (PSA)). See Fig. 4. Be sure application temperature and manufacturer’s installation temperature recommendations are in accordance adhered to.

10.2 *90° elbows–Fittings:* There are many types of fittings; pipe fittings, screwed fittings etc. See Fig. 5.

NOTE 1—As an alternative to field fabricated fittings, factory manufactured fittings are available for many configurations.

10.2.1 Fabricate 90° elbows from straight tubing. Cut the insulation at 45° angle. Reverse the pieces by 180° to each other. See Fig. 56. Apply contact adhesive to both faces and press firmly together when properly set. Slit open the formed bend by cutting through the throat or heel of fitting. Apply brush coat of contact adhesive to both longitudinal seams of the fabricated fitting. Place over bend and press seams firmly together. See Fig. 67. Fabricate 45s in a similar manner.

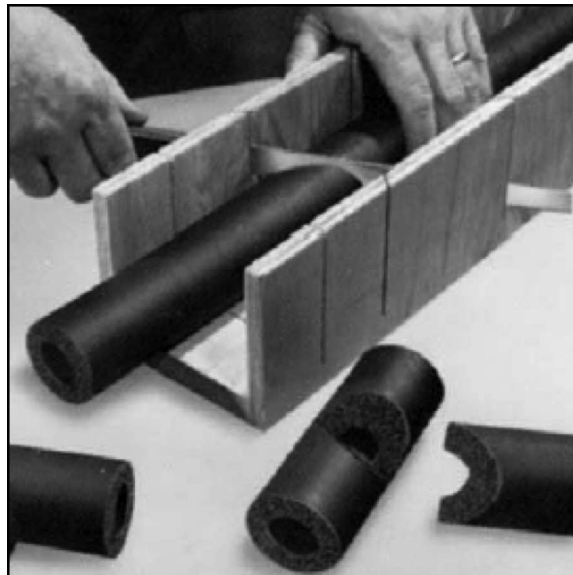

FIG. 1 USE Miter Box For Making Cuts

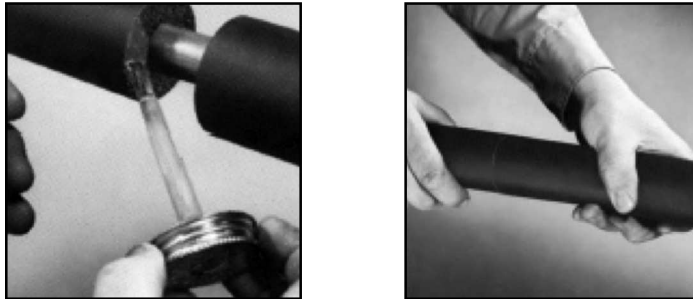
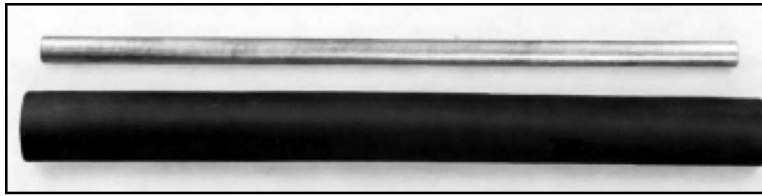

FIG. 2 Apply Adhesive to all Butt Joints Installed/Existing Pipe Work

10.2.2 *Optional (but not optimal) Method*—Slide insulation around 90. The product should be pushed, not pulled around the 90. Although sliding the insulation around a 90 is a technique that is used in the field, it is not recommended as the insulation thickness will be compromised (thinned) and condensation may occur on the outside edge as a result.

10.2.3 *Tee*—Fabricate tee by cutting a V notch (45°; cut) from straight section. Cut end of adjoining piece at 45° angle to fit into notch of section above. Apply contact adhesive to all cut faces, when properly dried, press fit insulation sections firmly together. Slit open the completed fitting section, apply contact adhesive to all exposed insulation wall faces, place cover over tee when adhesive is properly set and apply pressure to bond the fitting insulation. See Fig. 8.

10.2.4 *Valves*—In all cases, insulate as close to the fitting or valve as possible with straight tubing. Then insulate over or around the fitting or valve by sleeving appropriately sized insulation or flat sheet over the straight sections to create the correct build up of insulation. Seal all cutouts by adhering the insulation (with contact adhesive) to the pipe or body being insulated to prevent air (with moisture) or condensation intrusion into the system. See Figures Fig. 8 and Fig. 9.

10.3 *Tee and Valve*—Fabricate tee by cutting a V notch (45°; cut) from straight section. Cut end of adjoining piece at 45° angle to fit into notch of section above. Apply contact adhesive to all cut faces, when properly dried, press fit insulation sections firmly together. Slit open the completed fitting section, apply contact adhesive to all exposed insulation wall faces, place cover over tee when adhesive is properly set and apply pressure to bond the fitting insulation. See Fig. 7.

10.4 *Fittings*—There are several types of fittings: pipe fittings, screwed tee piece fittings (see Fig. 8)

10.4.1 *Valves*—In all cases, insulate as close to the fitting or valve as possible with straight tubing. Then insulate over or around the fitting or valve by sleeving appropriately sized insulation or flat sheet over the straight sections to create the correct build up of insulation. Seal all cutouts by adhering the insulation (with contact adhesive) to the pipe or body being insulated to prevent air (with moisture) or condensation intrusion into the system. See Figures Fig. 8 and Fig. 9.

10.3 *Large Diameter Pipe*—Large diameter pipe can be insulated with flat sheet. Refer to Fig. 10. Determine circumference of pipe (circumference = π x diameter + 1 in. (25mm)). Cut sheet to fit the circumference of pipe. Apply brush coat of contact adhesive to all insulation edges to be joined and sealed. Place insulation around pipe and firmly press seams together starting from the ends and working toward the center. Apply adhesive to butt ends and press adjoining straight insulation sections to fitting cover. On large pipe 12 in. (30 cm)) or greater apply adhesive to the bottom 1/3 of pipe to adhere insulation to pipe to prevent any sagging of insulation. Sheet can also be used to fabricate large diameter elbows and other fittings.

10.4 *Brazed Fittings*—When brazing pipe joints or fittings, ease insulation back along the pipe by 12 in. (30 cm) on each side of joint and restrain with clamps. When the brazed joint has fully cooled, apply a brush coat of adhesive to butt ends, when properly set press joints together. See Fig. 11.

10.5 *Pipe Hangers and Other Pressure Points*—Pipe Hangers or pressure points create a situation where the insulation can be compressed. Various techniques can be used to alleviate the insulation from being compressed; Wooden dowels can be used to form a tripod (load bearing) to bearing) to lift the pipe off the insulation. See Fig. 12. Hanger insulation supports also known as Saddles can be used to spread the weight of the pipe over a large area and to compensate for movement in the piping system but does not totally alleviate the issue of compressing the insulation (reducing the wall thickness) which may result in the formation of condensation.

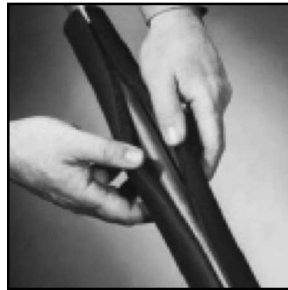

FIG. 3 Apply Unslit Insulation to Straight Pipe

10.6 *Tanks and Vessels*—Sheet or roll insulation can be used to insulate tanks and vessels. See Fig-13. Draw up a work schedule of the sizes needed to complete the job. Calculate the most efficient lay out available from standard sheets or rolls of insulation. Always cut material oversize, allowing ¼ in. (6.0 mm) extra to both length and width dimensions for press/compression fit. Contact adhesive or factory applied pressure sensitive adhesives (PSA) can be used to adhere the insulation to the surface. Follow manufacturer’s recommendations for adhesives, especially in confined spaces and for determining any flammability concerns. Refer to Material Safety Data Sheet (MSDS) on products. In all cases the metal surface should be clean, dry and free of dirt or any loose particles. Press the insulation firmly to the surface to be adhered to so the adhesive is thoroughly wetted out. Be careful to avoid trapping air under the insulation as it is applied. If contact adhesives are used (either brush or spray) apply to both surfaces (insulation and metal surface). Allow to set and apply by pressing firmly. When ambient temperatures are below 40°F, special precautions may be necessary because it takes a longer time for contact adhesives to tack up and PSAs lose their tack in colder temperatures.

10.7 Duct Covering:

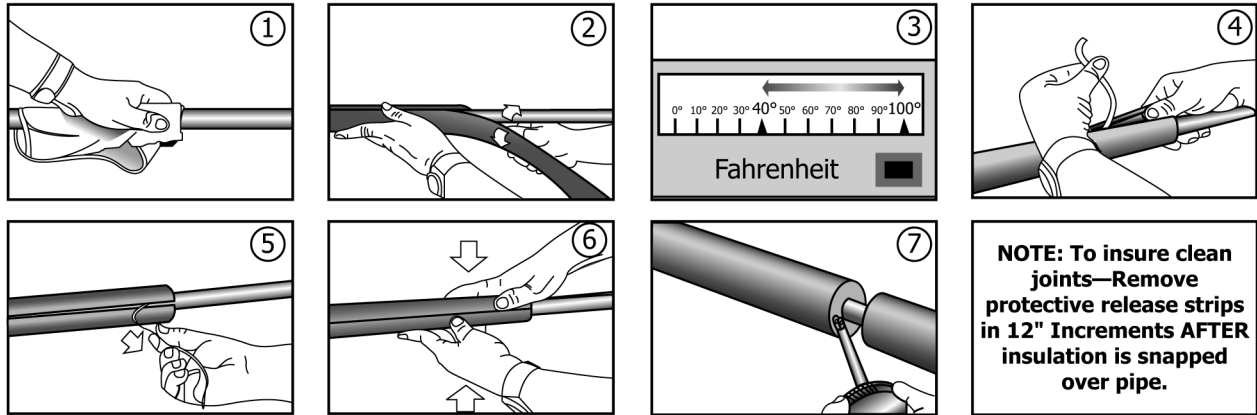

FIG. 4 Apply Pre-Slit/Pre-Glued Insulation to Straight Pipe

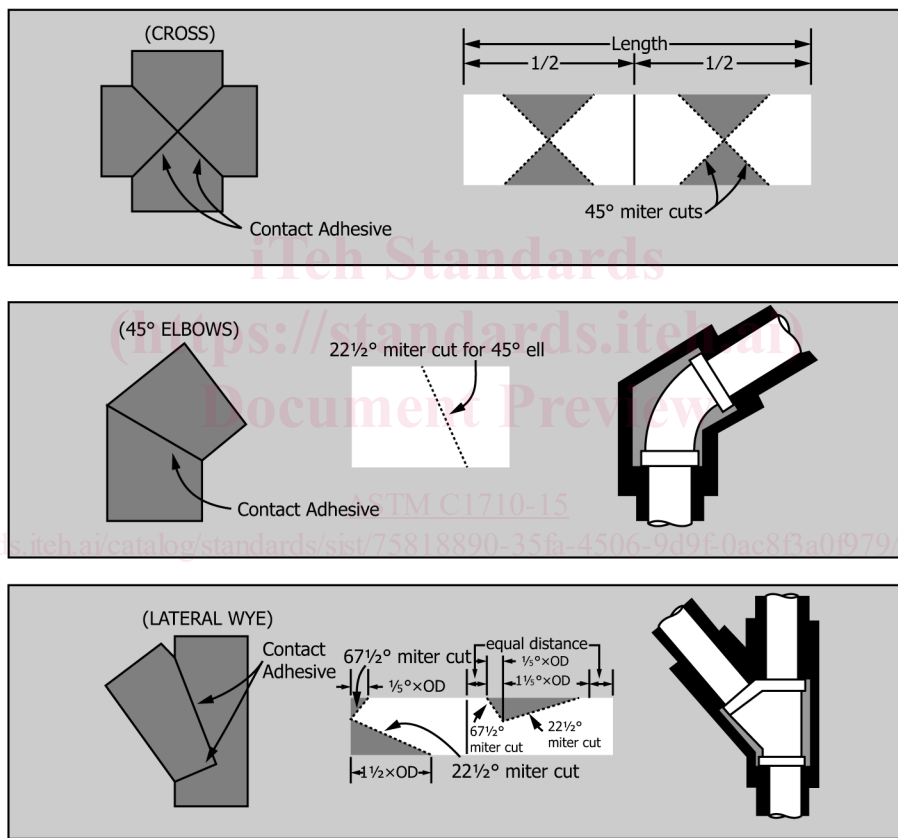

FIG. 5 Fabrication of Elbow Examples of Various Pipe Fittings

10.7.1 *Square or Rectangular*—Sheet or roll insulation can be used to wrap / cover ducts or air handling systems. The duct should be insulated in such a manner as to create a watershed on all seams, eliminating the possibility of water penetrating between a seam. This is accomplished by applying the bottom layer first, then the sides which overlap the bottom layer's exposed edge and finally the top section is applied to cover the exposed edges of the sides. Various kinds of adhesives can be used; solvent based contact, pressure sensitive or hot melt. 100 % adhesive coverage should be used. All seams should be glued. Pressure should be applied to the insulation to provide good contact between the insulation and the duct. The duct should be clean and free of dirt, grease etc. All standing ribs should be insulated to the same thickness as the rest of the duct. All ducts exposed to the outdoors should be protected from the elements with an appropriate coating, jacket or cladding. Large outdoor ducts should be pitched slightly to prevent ponding water. See Fig. 13.

10.7.2 *Round or Oval*—Round or oval ducts can be insulated with sheet or roll insulation. Small diameter ducts (12 in. or less) should be insulated similar to a pipe – only the longitudinal seam and butt joints are adhered. The insulation is not adhered to the duct. On larger duct, the insulation should be adhered to the duct at the 4 o'clock and 6 o'clock positions to prevent the insulation