



Designation: **G108 – 94 (Reapproved 2010) G108 – 94 (Reapproved 2015)**

## Standard Test Method for Electrochemical Reactivation (EPR) for Detecting Sensitization of AISI Type 304 and 304L Stainless Steels<sup>1</sup>

This standard is issued under the fixed designation G108; the number immediately following the designation indicates the year of original adoption or, in the case of revision, the year of last revision. A number in parentheses indicates the year of last reapproval. A superscript epsilon ( $\epsilon$ ) indicates an editorial change since the last revision or reapproval.

### 1. Scope

1.1 This test method covers a laboratory procedure for conducting an electrochemical reactivation (EPR) test on AISI Type 304 and 304L (UNS No. S30400 and S30403, respectively) stainless steels. This test method can provide a nondestructive means of quantifying the degree of sensitization in these steels (**1, 2, 3**).<sup>2</sup> This test method has found wide acceptance in studies of the effects of sensitization on intergranular corrosion and intergranular stress corrosion cracking behavior (see Terminology **G15**). The EPR technique has been successfully used to evaluate other stainless steels and nickel base alloys (**4**), but the test conditions and evaluation criteria used were modified in each case from those cited in this test method.

1.2 The values stated in SI units are to be regarded as the standard. The inch-pound units given in parentheses are for information only.

1.3 *This standard does not purport to address all of the safety concerns, if any, associated with its use. It is the responsibility of the user of this standard to establish appropriate safety and health practices and determine the applicability of regulatory limitations prior to use.*

### 2. Referenced Documents

2.1 *ASTM Standards*:<sup>3</sup>

**A262** Practices for Detecting Susceptibility to Intergranular Attack in Austenitic Stainless Steels

**D1193** Specification for Reagent Water

**E3** Guide for Preparation of Metallographic Specimens

**E7** Terminology Relating to Metallography

**E112** Test Methods for Determining Average Grain Size

**G1** Practice for Preparing, Cleaning, and Evaluating Corrosion Test Specimens

**G3** Practice for Conventions Applicable to Electrochemical Measurements in Corrosion Testing

**G5** Reference Test Method for Making Potentiodynamic Anodic Polarization Measurements

**G15** Terminology Relating to Corrosion and Corrosion Testing (Withdrawn 2010)<sup>4</sup>

**G28** Test Methods for Detecting Susceptibility to Intergranular Corrosion in Wrought, Nickel-Rich, Chromium-Bearing Alloys

**G61** Test Method for Conducting Cyclic Potentiodynamic Polarization Measurements for Localized Corrosion Susceptibility of Iron-, Nickel-, or Cobalt-Based Alloys

### 3. Terminology

3.1 *Definitions of Terms Specific to This Standard:*

3.1.1 *integrated charge ( $Q$ )*—the charge measured, in ~~coulombs~~, coulombs, during reactivation as given by the time integral of current density below the reactivation peak of the curve.

3.1.2 *maximum anodic current density ( $I_p$ )*—the current density measured at the peak of the anodic curve during reactivation.

<sup>1</sup> This test method is under the jurisdiction of ASTM Committee **G01** on Corrosion of Metals and is the direct responsibility of Subcommittee **G01.11** on Electrochemical Measurements in Corrosion Testing.

Current edition approved May 1, 2010/Nov. 1, 2015. Published May 2010/December 2015. Originally approved in 1992. Last previous edition approved in 2004/2010 as **G108 – 94(2004)G108 – 94(2010)**.<sup>1</sup> DOI: 10.1520/G0108-94R10.10.1520/G0108-94R15.

<sup>2</sup> The boldface numbers in parentheses refer to a list of references at the end of this standard.

<sup>3</sup> For referenced ASTM standards, visit the ASTM website, [www.astm.org](http://www.astm.org), or contact ASTM Customer Service at [service@astm.org](mailto:service@astm.org). For *Annual Book of ASTM Standards* volume information, refer to the standard's Document Summary page on the ASTM website.

<sup>4</sup> The last approved version of this historical standard is referenced on [www.astm.org](http://www.astm.org).

3.1.3 *normalized charge* ( $P_a$ )—the integrated current normalized to the specimen size and grain size.  $P_a$  represents the charge (in coulombs/cm<sup>2</sup>) of the grain-boundary area. The method for calculating  $P_a$  is given in 9.2.

3.1.4 *reactivation*—in the electrochemical reactivation (EPR) test, the potential sweep from the passivation potential returning to the corrosion potential.

3.1.5 *scan rate*—the rate at which the electrical potential applied to a specimen in a polarization test is changed.

#### 4. Summary of Test Method

4.1 The EPR test is accomplished by a potentiodynamic sweep from the passive to the active regions of electrochemical potentials in a process referred to as reactivation. The EPR test measures the amount of charge associated with the corrosion of the chromium-depleted regions surrounding chromium carbide precipitated particles. Most of these particles in a sensitized microstructure are located at grain boundaries (see Terminology E7). Discrete particles located within the grain (referred to as intragranular precipitates) will also contribute to the total measured charge. Therefore, it is important to examine the alloy microstructure following an EPR test, to determine the relative proportion of corrosion site associated with intergranular versus intragranular precipitates.

4.2 The chromium-depleted zones around carbide precipitates in sensitized steels are particularly susceptible to corrosion in oxidizing acid solutions. Corrosion at chromium-depleted grain boundary sites causes a rapid rise in the current density when the electrochemical potential is changed from the passive to the active region.

4.3 A sensitized steel produces a curve similar to the active portion of the polarization curve during the reactivation from the passive region back to the rest potential ( $E_{corr}$ ) as shown in Fig. 1. A nonsensitized (solution annealed) steel polarized under the conditions given in this test method will produce a curve with lower current densities than a sensitized steel.

4.4 The EPR test results are readily reproducible, as long as the electrolyte temperature, electrolyte composition, and scan rate are carefully controlled. The EPR test is significantly affected by the composition, thermomechanical condition and surface finish of the specimen as well as the presence of non-metallic inclusions, that result in pitting of the etched microstructure.

NOTE 1—Various cutting and grinding operations can promote sensitization of Type 304 (5). Superficial carbide precipitation can occur during cutting and grinding or during subsequent low temperature heat treatments, such as 24 h at 500°C.

4.5 The criteria used to distinguish between sensitized and solution annealed samples are the activation charge density,  $Q$  (given by the time integral of current density below the reactivation peak of the curve), or the maximum anodic current density,  $I_r$ , in the active state. Sensitized steels are easily activated and show higher  $Q$  and  $I_r$  values than solution annealed steels, that are not susceptible to intergranular corrosion. The value  $Q$  is normalized for both specimen size and grain size. The value normalized in this fashion is called  $P_a$  and represents the charge (in units of coulombs) per unit grain-boundary area. This normalization permits direct comparisons of different heats of material that exhibit different  $Q$  values solely as a result of differences in grain size.

#### 5. Significance and Use

5.1 This test method describes an EPR test method for quantitatively determining the relative degree of sensitization in AISI Type 304 and 304L stainless steels. The EPR test has found wide use as a means to provide a numerical level of sensitization in studies of the effects of sensitization on intergranular corrosion and intergranular stress corrosion cracking behavior. The results of this test method correlate with other test methods (for example, Practices A262 and Test Methods G28) that are commonly used to assess sensitization in stainless steels.

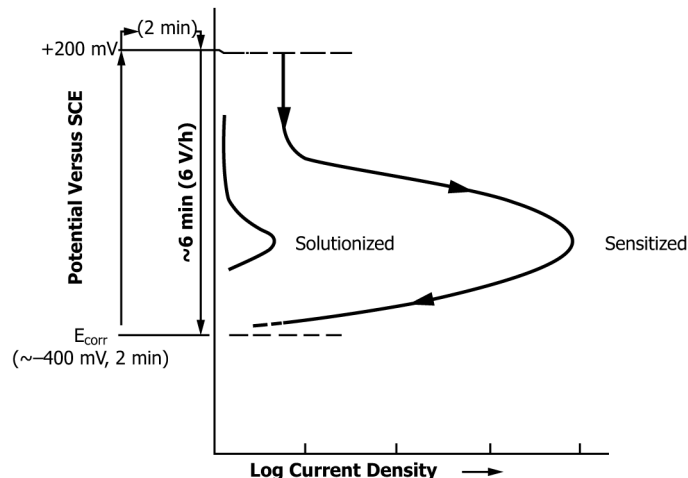

FIG. 1 Schematic EPR Curves for Sensitized and Solutionized AISI Type 304 Stainless Steel

5.2 The EPR test can also be used for product acceptance, service evaluation, regulatory statutes, and manufacturing controls providing that both the supplier and user have agreed upon appropriate acceptance criteria and a sensitizing treatment. The test is not intended for design purposes since the test conditions accelerate corrosion in a manner that does not simulate any actual service environment.

5.3 The EPR test involves the measurement of the amount of charge resulting from the corrosion of the chromium-depleted regions surrounding the precipitated chromium carbide particles. Most of these particles in a sensitized microstructure are located at the grain boundaries. However, discrete particles located within grains (referred to as intragranular precipitates) will also contribute to the total measured charge. (See Fig. 2.) Therefore, it is important to examine the alloy microstructure following an EPR test to determine the relative proportion of corrosion sites associated with intergranular versus intragranular precipitates. Sites of intergranular attack will appear similar to grain boundary ditching as defined in Practice A of Practices A262.

## 6. Apparatus

6.1 The apparatus necessary for obtaining EPR data consists of electronic instruments and a test cell. These instruments may be integrated into one instrument package or may be individual components. Either form of instrumentation can provide acceptable data.

6.2 Typical apparatus, as illustrated in Fig. 3, shall consist of the following: scanning potentiostat (or potentiostat/voltage ramp generator combination), potential measuring instrument, current and current integration measuring instruments, and test cell and specimen holder.

6.2.1 *Scanning Potentiostat*—Requirements shall be in accordance with 4.2 of Test Method G5 with the following refinements: the potentiostat shall control the potential within  $\pm 5$  mV accuracy over the range of potential and current density encountered in the EPR measurements. The potentiostat shall be operable in a potential range of  $-600$  to  $+500$  mV to  $+500$  mV (SCE) and a current density range of  $1 \mu\text{A}$  to  $100 \text{ mA/cm}^2$ . The applied potential is changed either automatically or manually in the following manners:

6.2.1.1 Shifting the potential from the open circuit potential to a potential in the passive range, and

6.2.1.2 Scanning back to the open circuit potential (reactivation) at a voltage scan rate of  $1.67 \text{ mV/s}$  ( $6 \text{ V/h}$ ).

6.2.2 *Potential Measuring Instruments*—Requirements shall be in accordance with 4.3 of Test Method G5 except that the potential range is as stated above.

6.2.3 *Current Measuring Instruments*—Requirements shall be in accordance with 4.4 of Test Method G5. However, current measurements are essential for passivation assessment and other intermediate checks of system stability. The currents encountered in EPR for a specimen with the dimensions given in 7.3 are in the range of  $1 \mu\text{A}$  to  $100 \text{ mA/cm}^2$ . For samples of less than  $100 \text{ mm}^2$  test area, currents above about  $20 \text{ mA/cm}^2$  rarely have been reported.

6.2.4 *Current Integration Measurement Instruments (Optional)*—Current integration, or charge, can be measured by an electronic device incorporated into the potentiostat, or by a separate electronic device, such as a coulometer. If a coulometer is used, it shall be capable of measuring charges from  $0.001$  to  $2$  coulombs. The use of a coulometer shall be considered optional. Charge can also be measured by using a chart recorder, as illustrated in Fig. 3, to record a current versus time trace and then, subsequently, integrating it by various methods. When potentiostat measurements are available in a digitized format, an appropriate computer integration routine can also be used to obtain a value for charge.

6.2.5 *EPR Test Cell*—Requirements shall be in accordance with 4.1 of Test Method G5. A deaeration tube is not required and only one counter electrode is required for EPR testing. A suitable cell and electrode arrangement is shown in Fig. 4.

6.2.6 *Electrode Holder*—Requirements shall be in accordance with 4.6 of Test Method G5 or 4.2.1 of Test Method G61. The requirements for the working electrode (specimen) and counter electrode holders are that the holders be made of an inert material and any seals must not allow leakage of the electrolyte. When using the Test Method G5-type holder the working electrode can be mounted as shown in Fig. 5 and described in Appendix X1.

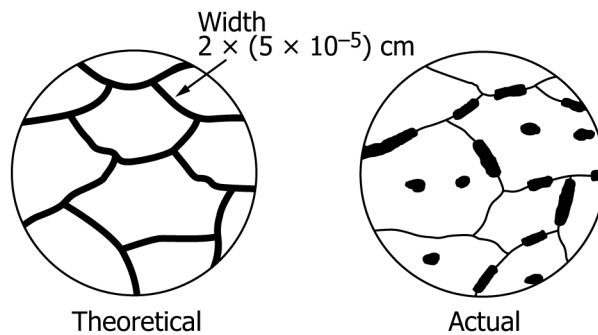

NOTE 1—The calculation of  $P_a$  is based on the assumptions illustrated at left. Mild cases of sensitization usually result in a combination of intergranular attack and pitting as illustrated at right (6).

FIG. 2 Schematic Microstructures After EPR Testing

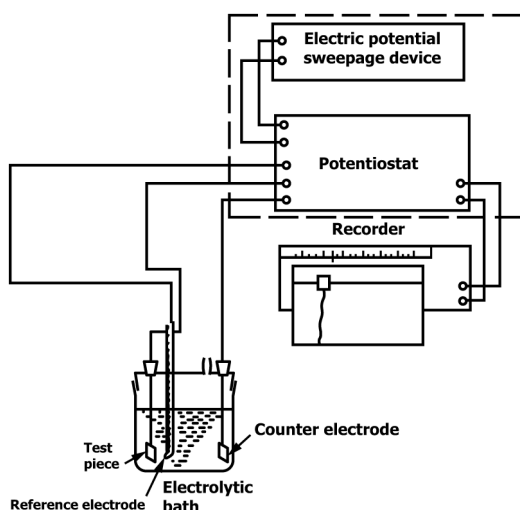
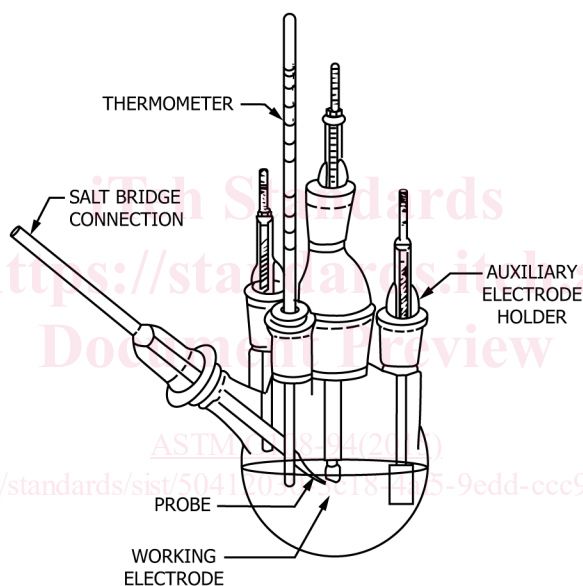

FIG. 3 Schematic Diagram of an EPR Test Apparatus



NOTE 1—The sample face is completely immersed but the connection to the electrode holder is not immersed.

FIG. 4 Schematic Diagram of an Electrochemical Cell for EPR Testing

6.2.7 *Auxiliary (Counter) Electrodes*—Requirements are in accordance with 4.7.2 of Test Method G5 except that only one counter electrode is necessary for EPR testing. However, two auxiliary electrodes can provide for a more uniform distribution of current. Titanium or high-purity carbon may be used in place of platinum for the counter electrode since it is always the cathode.

6.2.8 *Calomel Reference Electrode*—Requirements are in accordance or equivalent to 4.7.3 of Test Method G5.

## 7. Sampling, Test Specimens, and Test Units

### 7.1 Sampling:

7.1.1 When using this test method to meet product acceptance criteria, the means of sampling of a test specimen shall be decided by agreement between the parties involved; for instance, but not limited to, a user and a supplier.

7.1.2 Specimens removed from a piece of AISI Type 304 or 304L steel by shearing, cutting, burning, and so forth shall have the affected edges removed by grinding or machining.

7.2 *Sensitization of Test Specimens*—Specimens can be given a sensitizing treatment when it is desired to assess the influence of a thermal exposure during fabrication on corrosion resistance.

7.2.1 Specimens may be tested in a condition simulating that of the product as installed in service. Specimens may be welded or heat treated in as nearly the same manner as the product will experience in fabrication or service. The user and supplier must agree to the use and conditions of a sensitization treatment. The most common sensitizing treatment is 1 h at 675°C (1250°F) according to 15.3 of Practices A262.

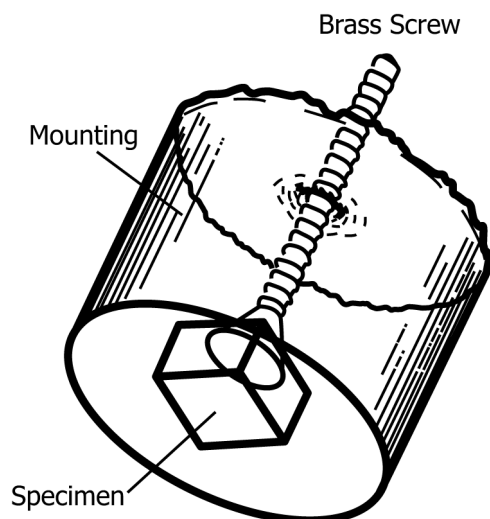

FIG. 5 A Method of Mounting Specimens for EPR Testing (6)

7.2.2 Heat treatment, particularly carburization, may alter the surface to be tested and may invalidate the EPR test results. Precautions shall be taken to ensure that the specimen surface is representative of the product form in service. Refer to Section 6 of Practice G1 for descaling procedures and 7.3, as well as Section 5 of Practices A262 for guidance in preparing specimens.

7.2.3 Expose specimens to be given a sensitization treatment prior to EPR testing in a furnace at the required temperature and for the required time and then water-quench. Use a thermocouple and a timer to ensure that the entire specimen cross sections are at the specified temperature for the specified amount of time. The number of thermocouples needed to obtain a reliable reading for all specimens exposed in a furnace at a given time is left to the discretion of the user.

### 7.3 Specimen Preparation:

7.3.1 Test specimens can be any shape but shall be at least 3.2 mm (0.125 in.) in diameter or on a side dimension and of a suitable thickness. Specimens shall not be larger than  $130 \text{ mm}^2$  (0.2 in.<sup>2</sup>) in area since such specimens will not fit into the recommended mold for mounting (see Appendix X1). A mounted specimen is illustrated in Fig. 5.

7.3.2 Remove any oxides or grease from the specimen as such film may promote loss of adhesion between the mounting compound and the specimen that could cause a crevice to form thereby producing erroneously high current densities during the EPR measurement.

7.3.3 The front surface of the specimen will be evaluated in the EPR test. The back surface of the test specimen is used to establish electrical contact with the specimen (see Note 2).

NOTE 2—A convenient way to make this attachment may be either by spot welding or by using a conducting cement to fasten a stainless steel machine screw (for example, NC4-40  $\times$  0.3 cm (0.75 in.) long) to the back surface of the specimen. This assembly is mounted in a suitable compound that is inert in the EPR electrolyte (see Appendix X1) such that the front surface upon immersion in the EPR electrolyte is fully in contact with the electrolyte.

7.3.4 Measure the surface area of the front surface of the test specimen within 0.1 mm<sup>2</sup> precision and record on the EPR data record sheet (see Appendix X2).

7.3.5 Specimens can be in any shape that will not be susceptible to crevice corrosion in the solution. Test surface area shall be at least  $10 \pm 0.1 \text{ mm}^2$  (0.016 in.<sup>2</sup>). It is occasionally useful to mask the area to be measured leaving an opening for exposure to the electrolyte. One suitable masking method uses precut pieces of an acid resistant tape. Care must be taken not to introduce undercutting of the tape during the EPR measurement because it will cause erroneously large currents.

## 8. Procedure

### 8.1 Metallographic Preparation:

8.1.1 Polish and attach the test specimen, mounted in a suitable inert compound, to the electrode holder following the procedures and cautions described below:

8.1.2 Exercise care since any crevice between the specimen and the mounting compound could lead to erroneously large current densities.

8.1.3 Prepare the surface within 1 h of the experiment, or store the prepared specimen in a suitable desiccating cabinet. Wet grind with 240-grit and 400-grit silicon carbide papers, and wet polish with 600-grit silicon carbide paper until all coarse scratches are removed. Rinse with water and dry. Polish the specimens in two additional stages with 6 and 1  $\mu\text{m}$  diamond paste on a low speed polishing wheel in accordance with Guide E3.

8.1.4 Polishing specimens on automated, high speed wheels using aluminum oxide slurries is not recommended. Specimens tend to retain an alumina impregnated surface layer that gives erroneous results during the EPR test.



8.1.5 Attach the specimen to the specimen holder as described in either 4.6.1 of Test Method **G5** or 4.2.1 of Test Method **G61**. In the case of the Test Method **G5**-type holder, tighten the assembly by holding the upper end of the mounting rod in a vise or clamp while turning the mounting nut until the gasket is properly compressed. Similarly for the Test Method **G61**-type holder, it is important to properly compress the TFE-fluorocarbon gasket to minimize the potential for crevice corrosion.

8.1.6 Clean the specimen just before immersion in the electrolyte by degreasing with a suitable detergent, rinsing in distilled water, then reagent grade methanol, and air drying.

### 8.2 Test Solution Preparation:

8.2.1 Prepare a mixture of reagent grade sulfuric acid ( $\text{H}_2\text{SO}_4$ ) and potassium thiocyanate (KSCN) in reagent water as follows: 1 L of 0.5 M  $\text{H}_2\text{SO}_4$  + 0.01 M KSCN and Type IV reagent water (in accordance with Specification **D1193**). The solution can be made up in bulk and stored for one month at room temperature. Transfer approximately 500 to 600 mL of solution to a clean test cell.

### 8.3 Initiating the Test:

8.3.1 Bring the temperature of the solution to  $30 \pm 1^\circ\text{C}$  by immersing the cell in a controlled temperature water bath or by other convenient means.

8.3.2 Place the specimen, counter electrodes, salt bridge probe, and other components in the test cell. Ensure the salt bridge is filled with the test solution and contains no air bubbles, particularly in the restricted space at the tip.

8.3.3 Record the open circuit potential (OCP) of the test specimen after 1 to 2 min of immersion. If the OCP is not consistent with typical values for the given alloy (for example, ~~-350~~ example,  $-350$  to  $-450$  mV versus SCE for AISI Type 304), cathodically polarize the specimen to  $-600$  mV versus SCE for 0.1 to 1 min and recheck the rest potential. If the rest potential is still abnormal (relative to the usual value around  $-200$  mV for solutionized Type 304 and 304L), the specimen must be removed from the cell and repolished (back to the step for polish with 1 or 6  $\mu\text{m}$  diamond paste is usually sufficient).

8.3.4 Passivation is accomplished by applying the potential to  $+200$  mV versus standard calomel electrode and holding for 2 min. For specimens  $1\text{ cm}^2$  or less in area, a current density of  $10\ \mu\text{A}/\text{cm}^2$  or less indicates that the specimen has passivated.

### 8.4 Reactivation Scan:

8.4.1 Set the current integration to zero and start the current integrator instrument. (Some instruments perform these steps automatically.) Start the potential scan in the active direction at the rate of  $1.67 \pm 0.08$  mV/s (6 V/h). During the reactivation scan, the current density will decay quite rapidly.

8.4.2 Record the reading on current integrator when potential reaches 50 mV above (more positive) the initial  $E_{\text{corr}}$ . This reading is the integrated current or charge value in coulombs. (Some instruments are capable of ending the experiment automatically.) The test is complete once this reading has been obtained.

8.4.3 Once the test is complete, put all electrochemical polarization equipment on standby. Remove the specimen from the cell and holder, rinse it in water, clean with alcohol or detergent, rinse again, and then air dry.

8.4.4 *Optional E Versus Log I Plot*—The recorder automatically plots the anodic polarization data on semilogarithmic paper in accordance with Practice **G3**. A strip chart recorder may also be used since potential is linear with time.

### 8.5 Metallographic Inspection:

8.5.1 Photograph surface of each specimen after testing (without additional preparation or etching) at a suitable magnification to determine grain size and to document the microstructures and extent of grain boundary attack. If the specimen is not sufficiently etched after the EPR test to delineate the microstructure for grain size determination, then the specimen shall be etched by either electrolytic 10 % oxalic acid (in accordance with Practice A of Practices **A262**), 60 %  $\text{HNO}_3$ -40 %  $\text{H}_2\text{O}$  (**7**), or by other suitable means to delineate the grain boundaries.

8.5.2 Examine the microstructure after the EPR test to ensure that the bulk of the integrated current  $Q$  value actually represents attack of the grain boundary areas (that is, “ditching” in terms of Practice A of Practices **A262** has occurred). Reactivation of intragranular (matrix) precipitates (principally chromium carbides) that may be present in substantial quantities in some specimens (**6**, **8**) may contribute to the integrated current  $Q$  value. Intragranular precipitates are only of concern when the  $Q$  value is above an established acceptance criteria. In such cases, the user and supplier may have to agree to higher acceptance criteria values that reflect the contribution of intragranular precipitates to the measured  $Q$  value. Examples of correlations of Pa values to the degree of sensitization for AISI Type 304 and 304L stainless steels are offered as a general guide to interpretation of EPR results in **Appendix X3**.

## 9. Calculation

9.1 Determine the surface area by measuring all dimensions to the nearest 0.1 mm.

9.2 Calculate and record the normalized charge ( $P_a$ ) in units of coulombs/ $\text{cm}^2$ , using the following equation:

$$P_a = Q/X \quad (1)$$

where: