

INTERNATIONAL STANDARD

**ISO
3776**

Second edition
1989-10-01

Tractors for agriculture — Seat belt anchorages

Tracteurs agricoles — Ancrages pour ceintures de sécurité

iTeh STANDARD PREVIEW
(standards.iteh.ai)

[ISO 3776:1989](#)

<https://standards.iteh.ai/catalog/standards/sist/ac70e4c1-16fb-4bef-8659-ee6d53f51c32/iso-3776-1989>



Reference number
ISO 3776 : 1989 (E)

Foreword

ISO (the International Organization for Standardization) is a worldwide federation of national standards bodies (ISO member bodies). The work of preparing International Standards is normally carried out through ISO technical committees. Each member body interested in a subject for which a technical committee has been established has the right to be represented on that committee. International organizations, governmental and non-governmental, in liaison with ISO, also take part in the work. ISO collaborates closely with the International Electrotechnical Commission (IEC) on all matters of electrotechnical standardization.

Draft International Standards adopted by the technical committees are circulated to the member bodies for approval before their acceptance as International Standards by the ISO Council. They are approved in accordance with ISO procedures requiring at least 75 % approval by the member bodies voting.

International Standard ISO 3776 was prepared by Technical Committee ISO/TC 23, *Tractors and machinery for agriculture and forestry*.

This second edition cancels and replaces the first edition (ISO 3776 : 1976), of which it constitutes a revision (see the introduction).

© ISO 1989

All rights reserved. No part of this publication may be reproduced or utilized in any form or by any means, electronic or mechanical, including photocopying and microfilm, without permission in writing from the publisher.

International Organization for Standardization

Case postale 56 • CH-1211 Genève 20 • Switzerland

Printed in Switzerland

Introduction

In the revision of this International Standard to adopt the seat index point (SIP) in place of seat reference point (SRP), the relationship of SIP 90 mm above and 140 mm in front of the SRP has been used. This relationship should be used when converting from SRP to SIP or vice versa.

The 1980 edition of ISO 3462, *Tractors and machinery for agriculture and forestry — Seat reference point — Method of determination* used a relationship of SIP 97 mm above and 130 mm in front of the seat reference point. In a practical comparison, however, it was found that the 90 mm vertical and the 140 mm horizontal relationship gave the most accurate conversion.

iTeh STANDARD PREVIEW

Variation from the 1980 edition of ISO 3462 is due to

(standards.iteh.ai)

- a) seat cushions not being horizontal in practice;
- b) seat cushion angle to backrest not being 90°;

ISO 3776:1989
<https://standards.iteh.ai/catalog/standards/sist/ac70e4cf-101b-4bec-8659-ee6d55151c32/iso-3776-1989>
 c) curvature of the backrest placing the SIP device slightly forward of the SRP device.

iTeh STANDARD PREVIEW

(standards.iteh.ai)
This page intentionally left blank

ISO 3776:1989

<https://standards.iteh.ai/catalog/standards/sist/ac70e4c1-16fb-4bef-8659-ee6d53f51c32/iso-3776-1989>

Tractors for agriculture — Seat belt anchorages

1 Scope

This International Standard specifies the requirements for the location of the anchorages for pelvic restraint belts for operators of tractors for agriculture fitted with a protective structure (cab or frame), the force that the anchorages shall be capable of withstanding and the tests to which they shall be subjected.

2 Normative reference

The following standard contains provisions which, through reference in this text, constitute provisions of this International Standard. At the time of publication, the edition indicated was valid. All standards are subject to revision, and parties to agreements based on this International Standard are encouraged to investigate the possibility of applying the most recent edition of the standard indicated. Members of IEC and ISO maintain registers of currently valid International Standards.

ISO 5353 : 1978, *Earth-moving machinery, and tractors and machinery for agriculture and forestry — Seat index point.*

3 Definition

For the purposes of this International Standard, the following definition applies.

anchorage: Appropriate part of the seat or tractor structure to which the seat belt can be secured.

4 Anchorages

4.1 Choice of anchorage location

Each seat belt shall have two anchorages. Where a suspended seat is used, the anchorages shall be fastened to the movable portion of the seat to permit travel with the operator, or means shall be provided to ensure that the belt is kept taut without chafing the seat occupant, while permitting free movement of the suspension. Where a non-suspended seat is used, the anchorages shall be placed such that they will not be forced out of position due to deformation of the protective structure when overturning.

4.2 Relative position of anchorages

The anchorages shall be positioned within the shaded area shown in figure 1, i.e. below a line at 20° to the horizontal and behind a line at 15° to the vertical, through a point 10 mm above and 40 mm behind the seat index point. The anchorages B₁, B₂ shall not be less than 175 mm nor more than 350 mm horizontal distance from the seat longitudinal plane of symmetry. However, if the seat structure makes it necessary, the lower limit may be reduced provided suitable arrangements ensure an appropriate spacing of the webbing where in contact with the operator's body.

4.2.1 Seat index point

The seat index point (SIP — see figure 1) shall be determined in accordance with ISO 5353 or its position with respect to the seat shall be specified by the seat manufacturer.

4.2.2 Webbing angle to horizontal

The angle of the webbing to the horizontal plane shall be as near as possible to 45° for all normal driving positions of the seat. It is accepted that the angle may vary from 45°: nevertheless, in no driving position shall the angle be less than 20° or greater than 75°.

4.3 Dimension of anchorage threaded holes

An anchorage shall consist of a threaded hole of 7/16-20 UNF 2 B.

NOTE — Where a seat belt is designed, fitted and supplied with the tractor by the tractor manufacturer, the 7/16 UNF thread specification need not apply, provided the anchorages supplied comply with all the other requirements of this International Standard.

5 Anchorage testing

5.1 Test type

Only static tests for the anchorages are given in this International Standard.

5.2 General

The tests may be carried out either on a shell or on a complete tractor.

The seat shall be in position during the tests, and fixed to the mounting point on the tractor or test bed using all intermediary fittings (such as suspension, slides, etc.) specified for the complete tractor. No additional non-standard fittings contributing to the strength of the construction may be used.

The anchorages shall be capable of withstanding the test specified in 5.3.

5.3 Test procedure and requirements

The seat belt anchorages shall be capable of withstanding a total tensile force equivalent to a load of at least 4 500 N at 45° to the horizontal applied substantially in the longitudinal centre-

plane of the seat using a device as shown in figure 2. The seat belt anchorages shall be capable of withstanding this test load applied with the seat at the seat adjustment mid-position and at one other adjustment position, if such a position is considered by the test station to be the worst case, to ensure that the test condition is met. The horizontal distance between the point where the load generation apparatus is attached to the test rig and the nearest seat belt anchorage point shall not be less than 1 000 mm.

If during application of the test load, deflection of the anchorage exceeds 100 mm in any direction, the test shall be terminated.

5.4 Accuracy of recording and loading

The test load shall be recorded using measuring devices having an accuracy of at least $\pm 5\%$. The load application angle shall be within $\pm 2^\circ$ of 45°.

iTeh STANDARD PREVIEW (standards.iteh.ai)

[ISO 3776:1989](https://standards.iteh.ai/catalog/standards/sist/ac70e4c1-16fb-4bef-8659-ee6d53f51c32/iso-3776-1989)

<https://standards.iteh.ai/catalog/standards/sist/ac70e4c1-16fb-4bef-8659-ee6d53f51c32/iso-3776-1989>

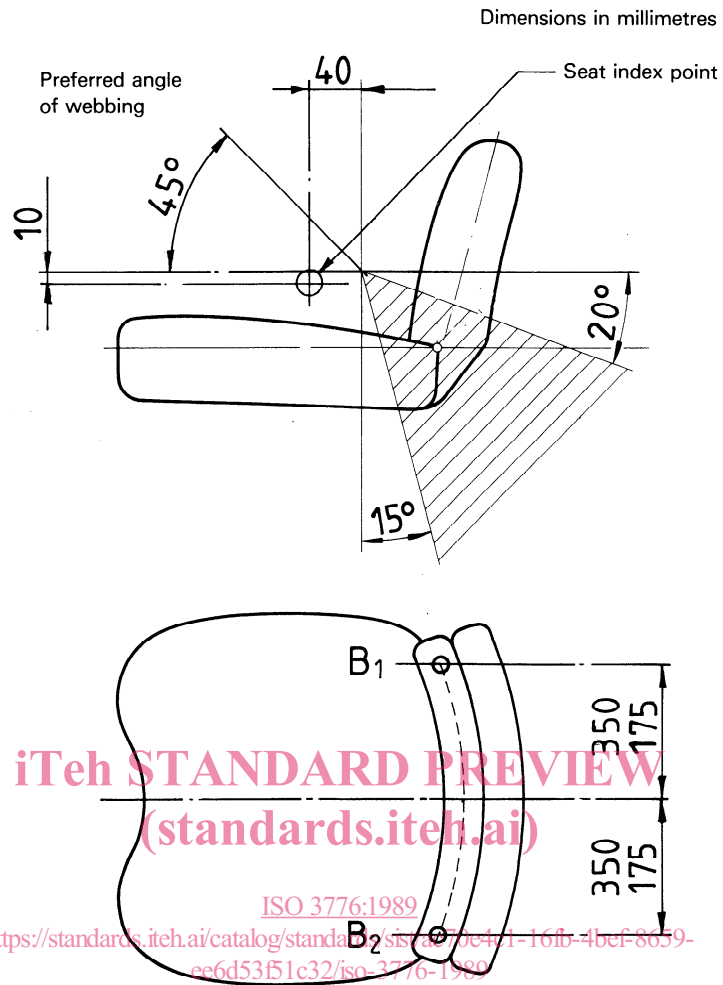

Figure 1 — Relative position of anchorages

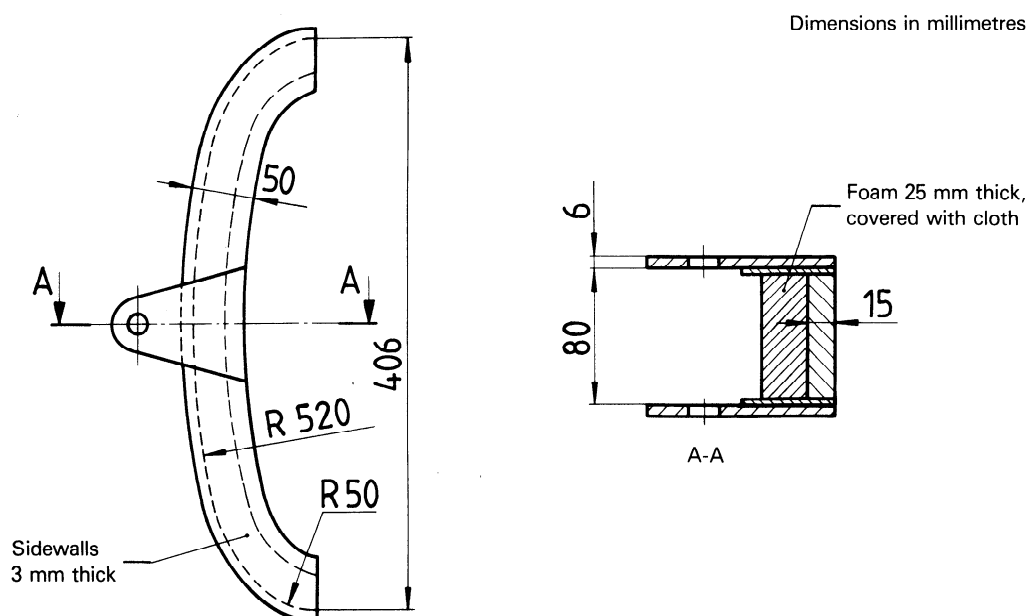

Figure 2 — Traction device

iTeh STANDARD PREVIEW
(standards.iteh.ai)

ISO 3776:1989

<https://standards.iteh.ai/catalog/standards/sist/ac70e4c1-16fb-4bef-8659-ee6d53f51c32/iso-3776-1989>

UDC 631.372-783.4

Descriptors : agricultural machinery, tractors, agricultural tractors, safety devices, safety belts, anchorages, specifications, tests.

Price based on 3 pages
