



Designation: **E750–10** E750 – 15

Standard Practice for Characterizing Acoustic Emission Instrumentation¹

This standard is issued under the fixed designation E750; the number immediately following the designation indicates the year of original adoption or, in the case of revision, the year of last revision. A number in parentheses indicates the year of last reapproval. A superscript epsilon (ϵ) indicates an editorial change since the last revision or reapproval.

1. ~~Scope~~ Scope*

1.1 This practice is recommended for use in testing and measuring operating characteristics of acoustic emission electronic components or units. (See [Appendix X1](#) for a description of components and units.) It is not intended that this practice be used for routine checks of acoustic emission instrumentation, but rather for periodic evaluation or in the event of a malfunction. The sensor is not addressed in this document other than suggesting methods for standardizing system gains (equalizing them channel to channel) when sensors are present.

1.2 Where the manufacturer provides testing and measuring details in an operating and maintenance manual, the manufacturer's methods should be used in conjunction with the methods described in this practice.

1.3 The methods (techniques) used for testing and measuring the components or units of acoustic emission instrumentation, and the results of such testing and measuring should be documented. Documentation should consist of photographs, screenshots, charts or graphs, calculations, and tabulations where applicable.

1.4 AE systems that use computers to control the collection, storage, display, and data analysis, might include waveform collection as well as a wide selection of measurement parameters (features) relating to the AE signal. The manufacturer provides a specification for each system that specifies the operating range and conditions for the system. All calibration and acceptance testing of computer-based AE systems must use the manufacturer's specification as a guide. This practice does not cover testing of the computer or computer peripherals.

1.5 The values stated in SI units are to be regarded as standard. No other units of measurement are included in this standard.

1.6 *This standard does not purport to address all of the safety concerns, if any, associated with its use. It is the responsibility of the user of this standard to establish appropriate safety and health practices and determine the applicability of regulatory limitations prior to use.*

2. Referenced Documents

2.1 *ASTM Standards:*² <https://standards.iteh.ai/catalog/standards/sist/c2945b04-17e9-410b-ba66-cae3c8a88987/astm-e750-15>

[E1316 Terminology for Nondestructive Examinations](#)

2.2 *ANSI Standard:*

[ANSI/IEEE 100-1984 Dictionary of Electrical and Electronic Terms](#)³

2.3 *Other Documents:*

[Manufacturer's Operating and Maintenance Manuals pertinent to the specific instrumentation or component](#)

3. Terminology

3.1 *Definitions*—For definitions of additional terms relating to acoustic emission, refer to Terminology [E1316](#).

4. Summary of Practice

4.1 Tests and measurements should be performed to determine the instrumentation bandwidth, frequency response, gain, noise level, threshold level, dynamic range, signal overload point, dead time, and counter accuracy.

¹ This practice is under the jurisdiction of ASTM Committee [E07](#) on Nondestructive Testing and is the direct responsibility of Subcommittee [E07.04](#) on Acoustic Emission Method.

Current edition approved ~~Jan. 1, 2010~~ Dec. 1, 2015. Published ~~February 2010~~ December 2015. Originally approved in 1980. Last previous edition approved in ~~2004~~ 2010 as ~~E750–04~~ E750 – 10. DOI: ~~10.1520/E0750-10~~ 10.1520/E0750-15.

² For referenced ASTM standards, visit the ASTM website, www.astm.org, or contact ASTM Customer Service at service@astm.org. For *Annual Book of ASTM Standards* volume information, refer to the standard's Document Summary page on the ASTM website.

³ Available from American National Standards Institute (ANSI), 25 W. 43rd St., 4th Floor, New York, NY 10036.

*A Summary of Changes section appears at the end of this standard

4.2 Where acoustic emission test results depend upon the reproduced accuracy of the temporal, spatial, or spectral histories, additional measurements of instrumentation parameters should be performed to determine the specific limits of instrumentation performance. Examples of such measurements may include amplifier slew rate, gate window width and position, and spectral analysis.

4.3 Tests and measurements should be performed to determine the loss in effective sensor sensitivity resulting from the capacitive loading of the cable between the preamplifier and the sensor. The cable and preamplifier should be the same as that used for the acoustic emission tests without substitution. (See also Appendix [Appendix X2](#).)

4.3.1 Important tests of a computer-based AE system include the evaluation of limits and linearity of the available parameters such as:

- (a) Amplitude,
- (a) Amplitude,
- (b) Duration,
- (c) Rise Time,
- (d) Energy, and
- (e) AE Arrival Time.

(b) Duration,

(c) Rise Time,

(d) Energy, and

(e) AE Arrival Time.

4.3.2 The processing speed of these data should be measured as described in [7.4.3](#) for both single- and multiple-channel operation.

4.3.3 The data storage capability should be tested against the specification for single- and multiple-channel operation. Processing speed is a function of number of channels, parameters being measured, timing parameter settings, AE signal duration, front-end filtering, storage device (RAM, disk), and on-line analysis settings (number of graphs, data listings, location algorithms, and more). If waveform recording is used, this may influence the processing speed further.

5. Significance and Use

5.1 This practice provides information necessary to document the accuracy and performance of an Acoustic Emission system. This information is useful for reference purposes to assure that the instrumentation performance remains consistent with time and use, and provides the information needed to adjust the system to maintain its consistency.

5.2 The methods set forth in this practice are not intended to be either exclusive or exhaustive.

5.3 Difficult or questionable instrumentation measurements should be referred to electronics engineering personnel.

5.4 It is recommended that personnel responsible for carrying out instrument measurements using this practice should be experienced in instrumentation measurements, as well as all the required test equipment being used to make the measurements.

6. Apparatus

6.1 The basic test instruments required for measuring the operating characteristics of acoustic emission instrumentation include:

- 6.1.1 *Variable Sine Wave Generator or Oscillator,*
- 6.1.2 *True RMS Voltmeter,*
- 6.1.3 *Oscilloscope,*
- 6.1.4 *Variable Attenuator, graduated in decibels, and*
- 6.1.5 *Tone Burst Generator.*

6.2 Additional test instruments may be used for more specialized measurements of acoustic emission instrumentations or components. They are as follows:

- 6.2.1 *Variable-Function Generator,*
- 6.2.2 *Time Interval Meter,*
- 6.2.3 *Frequency Meter, or Counter,*
- 6.2.4 *Random Noise Generator,*
- 6.2.5 *Spectrum Analyzer,*
- 6.2.6 *D-C Voltmeter,*
- 6.2.7 *Pulse-Modulated Signal Generator,*
- 6.2.8 *Variable Pulse Generator, and*
- 6.2.9 *Phase Meter, and*
- 6.2.10 *Electronic AE Simulator* (or an Arbitrary Waveform Generator (AWG) can be used providing an automated evaluation).

6.3 An electronic AE simulator (or AWG) is necessary to evaluate the operation of computer-based AE instruments. A detailed example of the use of an electronic AE simulator (or AWG) is given in [7.4.3](#) under dead time measurement. The instruction manual

for the electronic AE simulator provides details on the setup and adjustment of the simulator. Control of pulse frequency, rise time, decay, repetition rate, and peak amplitude in the simulator makes it possible to simulate a wide range of AE signal conditions.

7. Measurement Procedure

7.1 Frequency Response and Bandwidth Measurements:

7.1.1 The instrumentation, shown in Fig. 1, includes the preamplifier with amplification and signal filters, possibly connected to the AE system which might have additional signal filters, amplification, and interconnecting cables. All measurements and tests should be documented. If the preamplifier is to be tested without the AE system connected, it should be terminated with the normal working load as shown on the bottom right of Fig. 1.

7.1.2 An acceptable frequency response should be flat between cutoff frequencies within 3 dB of the reference frequency. The reference frequency is the geometric mean of the nominal bandwidth of the instrumentation. The mean frequency is calculated as follows:

$$f_M = (f_L f_H)^{\frac{1}{2}}$$

where:

- f_M = mean frequency,
- f_L = nominal lower cutoff, and
- f_H = nominal upper cutoff.

7.1.3 The bandwidth should include all contiguous frequencies with amplitude variations as specified by the manufacturer. Instruments that include signal processing of amplitude as a function of frequency should have bandwidth amplitude variations as specified by the manufacturer.

7.1.4 With the instrumentation connected to the oscillator and attenuator, see Fig. 1 and the sine wave oscillator set well within the instrumentation’s specified dynamic range, the frequency response should be measured between frequency limits specified in 7.1.2. The oscillator is maintained at a fixed amplitude and the frequency is swept through the frequency limits. The preamplifier or AE system voltage output is monitored with an RMS voltmeter. Values of amplitude are recorded for each of several frequencies within and beyond the nominal cutoff frequencies. The recorded values should be plotted. The amplitude scale may be converted to decibels. The frequency scale may be plotted either linearly or logarithmically. Appendix X2 provides further discussion of wave shaping components.

7.1.5 A spectrum analyzer may be used in conjunction with a white noise source or an oscilloscope may be used in conjunction with a sweep frequency oscillator to determine bandwidth. With a white noise source connected to the input, a spectrum analyzer connected to the output will record the frequency response.

7.1.6 The measured bandwidth is the difference between the corner frequencies at which the response is 3 dB less than the response at the reference frequency.

7.2 Gain Measurements:

7.2.1 The electronic amplification is comprised of the preamplifier gain, the wave filters insertion gains or losses and the AE system’s gains or losses. (See Appendix X2 for an explanation of gain measurements.)

7.2.2 The electronic amplification may be measured with the test setup shown in Fig. 1, with the oscillator and attenuator connected. The sine wave oscillator is set to the reference frequency. The oscillator amplitude is set well within the dynamic range of the instrumentation to avoid distortion due to overload. With the voltmeter at V_{osc} , oscillator amplitude is set to 1 V. The attenuator is set for a value greater than the anticipated electronic amplification. Next, the voltmeter is moved to V_{out} (preamplifier or AE system voltage output depending on the test being performed). The attenuator is now adjusted until the voltmeter again reads

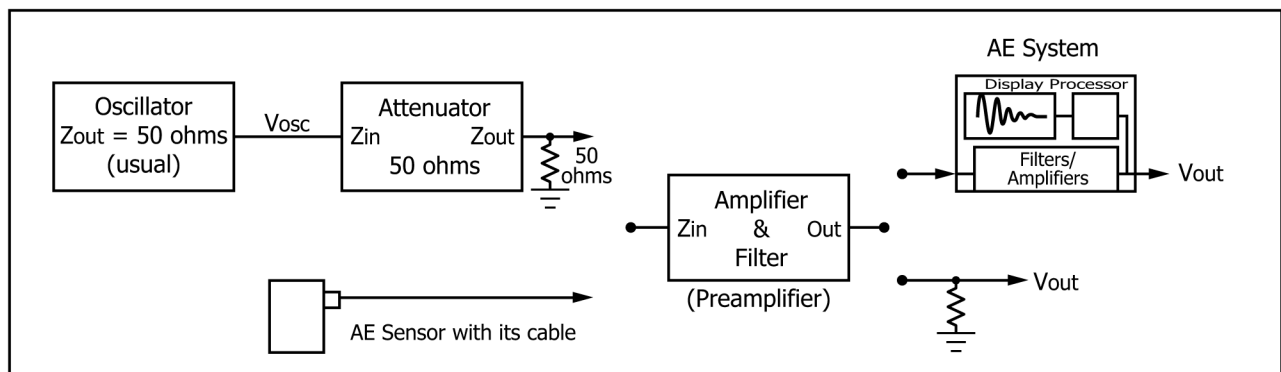

FIG. 1 Component Configuration Used for Testing and Measuring the Frequency Response, Amplification, Noise, Signal Overload, Recovery Time, and Threshold of Acoustic Emission Instrumentation

1 V. The electronic amplification is equal to the new setting on the attenuator. A white noise generator or sweep generator and spectrum or FFT analyzer may be used in place of the oscillator and RMS voltmeter.

NOTE 1—If the input impedance of the preamplifier is not both resistive and equal to the required load impedance of the attenuator, proper compensation should be made.

7.3 *Dynamic Range Measurements:*

7.3.1 The criterion used for establishing dynamic range should be documented as the signal overload point, referenced to the instrumentation noise amplitude, while keeping like measurements for both readings (for example, peak voltage to peak voltage, peak-peak voltage or RMS to RMS readings). Alternatively, the reference amplitude may be the threshold level if the instrumentation includes a voltage comparator for signal detection. The total harmonic distortion criterion should be used for signal processing involving spectrum analysis. All other signal processing may be performed with the signal overload point criterion.

7.3.2 The dynamic range (DR) in decibels should be determined as follows:

$$DR = 20 \log_{10}(\text{signal overload point voltage}/\text{background noise voltage})$$

7.3.2.1 The dynamic range of instrumentation exclusive of threshold or voltage comparator circuits, is a ratio of the signal overload level to the noise amplitude. (A brief description of noise sources appears in [Appendix X4](#)). An oscilloscope is usually required as an adjunct to determine the characteristics of noise and to monitor the signal overload point.

7.3.2.2 A field measurement of dynamic range may produce substantially different results when compared with a laboratory measurement. This difference is caused by an increase in the reference voltage output, and may result from noise impulses of electrical origin, or ground faults.

7.3.2.3 For an amplifier that has a threshold comparator as its output device, the dynamic range is the ratio of maximum threshold level to input noise level at the comparator. Excess amplitude range in the amplifier contributes to overload immunity but not to the dynamic range. The following measurement will give the effective dynamic range:

$$DR_e = 20 \log_{10}(\text{MaxTh}/\text{MinTh})$$

where:

DR_e = the effective dynamic range of the system,

MaxTh = the highest settable threshold value that just passes the largest undistorted peak signal input, and

MinTh = the threshold value that passes less than 1 count/s with no input signal.

This dynamic range is the difference between the largest and the smallest AE input that can be reliably detected by the system.

7.3.3 Measurement of instrument electronic noise is accomplished by replacing the oscillator/attenuator of [Fig. 1](#), with the sensor that will be used, including its cable (or with a lumped equivalent capacitance). A lumped capacitance represents the electrical characteristic of the sensor and cable combination without adding mechanical noise interference. The RMS noise voltage is measured with a true RMS voltmeter (see [6.1.2](#)) at the instrumentation (preamplifier or AE system) output (V_{out}) per [Fig. 1](#). Alternatively, a peak AE system noise measurement can be measured by setting the lowest possible AE threshold which passes less than one false hit within ten seconds or by setting the AE system threshold below the noise and recording the peak AE amplitude of hits detected in a ten second period.

7.3.4 The signal overload level is measured by replacing the sensor with the sine wave oscillator as shown in [Fig. 1](#). The frequency is set to the mid-band frequency of the instrumentation. The oscillator amplitude is fixed at 1 V peak to peak monitored at V_{osc} . The attenuator is adjusted to increase the signal level to the preamplifier until the instrumentation output (V_{out}) is 0.5 dB less than the computed output.

7.3.5 Should the peak amplitude of acoustic emission activity exceed the dynamic range, several deleterious effects may be produced; these include clipping, saturation, and overload recovery time-related phenomena. (See [Appendix X2](#) for a discussion of overload recovery.) The instrumentation gain should be adjusted to limit these effects to an absolute minimum in order to increase the reliability of the data.

7.4 *Dead Time Measurements:*

7.4.1 The instrumentation dead time may include variable and fixed components, depending on the instrumentation design for handling the routine of the input and output data processing. The components included in dead time are process time and lock-out time. Process time varies from system to system and usually depends on the number of parameters processed for each AE hit. Lock-out time, which may be operator controlled, is used to force a time delay before accepting new AE hits.

7.4.2 Dead time measurement in a counter type AE instrument should be conducted as follows: Set the instrument to the count rate mode. Set the oscillator frequency to the mid-band frequency of the instrument. Set the oscillator amplitude to achieve a count rate equal to the oscillator frequency. Increase the oscillator frequency until the count rate ceases to equal the oscillator frequency. Record the frequency as the maximum count rate. (If the frequency is equal to or greater than the specified upper frequency limit of the instrument, the dead time of the counter is zero.) Dead time (Td) is given by:

$$Td = 1/Fm - 1/Fu$$

where:

Fm = the measured frequency, and

F_u = the upper bandwidth limit of the instrument.

7.4.3 Where the dead time in question is related to AE hit processing such as measurement of source location, energy, duration, or amplitude, the measurement is best accomplished by using an electronic AE simulator as follows:

7.4.3.1 Select an AE hit parameter to evaluate the dead time.

7.4.3.2 Set the electronic AE simulator frequency, rise, decay, duration, and repetition rate such that the observed AE hit rate in the selected parameter equals the repetition rate of the simulator.

7.4.3.3 Increase the repetition rate of the simulator until the observed AE hit rate falls below the simulator rate.

7.4.3.4 Record this value as maximum AE hit rate (processing speed) for the selected parameter.

7.4.4 The dead time (T_d) is given by:

$$T_d = 1/R_B - D_B$$

where:

D_B = the selected burst duration, and

R_B = the repetition rate of the simulator where the limit was found.

This dead time measurement procedure should be performed for each AE hit-based parameter of the AE system.

7.5 Threshold Level (Threshold of Detection) Measurements:

7.5.1 Various acoustic emission signal processing instruments rely upon the signal exceeding a comparator voltage level to register a hit. This level may be fixed, adjustable, floating and fixed, or floating and adjustable. The floating threshold may be called automatic threshold. Signal recognition (or hit) does not occur until the threshold is exceeded.

7.5.2 The nonautomatic threshold level should be measured with the instrumentation assembled as shown in Fig. 1 and the signal processors attached to the point V_{out} . The signal processors are frequently digital electronic counters that may follow the secondary amplifier. Increasing the oscillator amplitude will result in an increasing signal level at V_{out} . The counters will begin counting when the signal at the comparator reaches the preset threshold level. This level measured with an oscilloscope connected to V_{out} multiplied by the gain of the secondary amplifier is equal to the threshold voltage. Some counters and other signal processors utilizing threshold detection are frequency sensitive. Therefore, the threshold level should be measured over the instrumentation bandwidth.

7.5.3 The automatic threshold cannot be measured with a continuous-wave generator because the automatic threshold level is usually derived from the rectified and averaged input signal. The tone burst generator provides an adjustable burst amplitude duration and repetition rate that may be used to establish the threshold level using the same technique that is used in 7.5.2. The automatic threshold level's affected by the tone burst amplitude, duration, and repetition rate.

7.6 Counter Accuracy Measurements:

7.6.1 Counters are of two types: summation counters and rate counters. Counters that tally signals for fixed repetitive periods of time during an acoustic emission test are known as rate counters. The tallied signals may be a count of acoustic emission signals, loading cycles, or amplitude levels.

7.6.2 The accuracy of the counting function of the instrumentation should be measured using a tone burst generator set as follows: (1) the amplitude should be well above the threshold level, but well within the dynamic range of the instrumentation; (2) the tone burst frequency should be within the instrumentation nominal bandwidth; (3) the tone burst duration should be at least one cycle, but fewer cycles than would cause the automatic threshold to take effect; (4) the tone burst repetition rate should be adjusted for a period that does not cause the automatic threshold to interfere with the count function. The counting accuracy is assured by comparing the emission count with the tone burst count.

7.7 Computer-Measured Parameters:

7.7.1 The limits and linearity of AE parameters recorded by computer-based systems may be measured by means of an electronic AE simulator. The electronic AE simulator provides individually adjustable amplitude, duration, rise time, and relative arrival time. Burst energy from the AE simulator may be calculated from the parameters given.

7.7.2 The limits or dynamic range and linearity of each parameter should be measured as follows for amplitude, duration, and rise time:

7.7.2.1 Connect the AE simulator to the preamplifier input of the channel to be tested.

7.7.2.2 Set up the AE system to record and display the parameter to be tested.

7.7.2.3 Adjust the AE simulator to produce a mid range simulated AE signal where the displayed amplitude, duration, and rise time are 10 % of their maximum value as specified by the AE system manufacturer.

7.7.2.4 Record the value of each parameter at the electronic AE simulator output and at the AE system display.

7.7.2.5 To measure upper limits for each parameter, increase the measured input in equal increments (for example, 10 % of maximum) and record the displayed value for that parameter until the output differs from the input by 10 % or the specified maximum value is exceeded.

7.7.2.6 To measure lower limits for each parameter, adjust input-output condition as in 7.7.2.3, then decrease the input in equal increments (for example, 10 % of the initial value) and record the displayed value until the output differs from the input by 10 % or the minimum value specified by the AE system manufacturer is reached.

7.7.2.7 To test the computer-derived energy per AE hit parameter, it is necessary to calculate the input energy from the electronic AE simulator in accordance with the method used by the AE system. For example, one method used in some AE systems computes approximate burst pulse AE hit energy (E) as follows:

$$E \cong DV^2/2$$

where:

D = burst duration, and
 V = peak amplitude.

7.7.2.8 Set the initial conditions as in 7.7.2.3. Increment input amplitude to obtain approximately 10 % of full scale change in energy input. Record the displayed energy per AE hit value at each increment until the output differs from the input by 10 % or the maximum value specified by the AE system manufacturer is exceeded. Repeat this process with amplitude fixed at the initial value while incrementing pulse duration.

7.7.2.9 Again repeat the process with amplitude and pulse duration except decrease each parameter until the minimum value specified by the manufacturer is reached or no further change in the output is produced.

7.7.3 The source location computational algorithm is a complex computer process not covered by this document. However, a multichannel electronic AE simulator may be used to check the location accuracy of systems that rely on the constancy of sound velocity to calculate location. For anisotropic materials where velocity is not constant, other source location algorithms exist such as area location based on first hit sensor.

7.7.3.1 Set up the AE system for source location in accordance with the operator's manual.

7.7.3.2 Set up the multichannel electronic AE simulator to provide simulated AE inputs to the appropriate number of channels.

7.7.3.3 Using the appropriate velocity of sound for the simulated structure, compute the times of flight from the simulated AE source position to each sensor of the source location array. The differences between the times of flight give relative arrival times (ΔT) for the simulated AE sensor positions.

7.7.3.4 Record the displayed location coordinates for this initial simulated input. Compute and input a new ΔT set for a nearby point. Record the difference between input position and displayed position. Continue this incremental movement of the simulated AE source away from the sensor array center until the output position differs from the input position by 10 % or the source location range specified by the AE system manufacturer is exceeded. Evaluate any error with respect to the AE system manufacturer's specification for source location linearity.

7.7.3.5 The source location test procedure should be repeated for two additional rays extending in different directions from the array center.

7.7.3.6 The source location procedure should be repeated for each multichannel array of the system.

7.8 Evaluating Waveform Accuracy in Digital AE Systems:

7.8.1 Digital AE systems work by digitizing and processing the AE waveform, using high performance analog-to-digital converters (ADC) and digital signal processors (DSP). The accuracy of the processed and stored AE waveforms is important for post processing and may be evaluated using an electronic AE simulator. The electronic AE simulator provides adjustable amplitude and frequency for evaluating waveforms.

7.8.2 The limits or dynamic range and distortion-free output should be evaluated as follows for waveform amplitude and frequency:

7.8.2.1 Connect the AE simulator, and an oscilloscope input, to the preamplifier input of the AE channel to be evaluated.

7.8.2.2 Adjust the AE simulator to produce a mid-range amplitude (e.g. 60 dB_{AE} or 1 millivolt peak), simulated, AE waveform. Also, set the AE simulator for a mid-range frequency waveform (e.g. 150 kHz), making sure the frequency filtering in the AE system is set for no attenuation in the passband.

7.8.2.3 Set up the AE system to record and display the waveform to be evaluated.

7.8.2.4 Compare the waveforms at the AE simulator output and at the AE system display, with waveform graphs set to the same time and amplitude range. Verify that the AE system output waveform is a match in shape and identical in peak voltage within 5%. Also, evaluate the output waveform for distortion, this would include any mis-shaped sinewaves as well as any large changes in amplitude or frequency output.

7.8.2.5 Measure upper limits for each parameter (amplitude or frequency) by increasing the measured input in equal increments, one value at a time (for example, 10 dB changes) and compare the two waveforms as described in 7.8.2.4. Include a maximum amplitude setting at, or close to 100 dB_{AE}, to evaluate if saturation effects exist. The threshold may need to be adjusted to avoid triggering on background noise.

7.8.2.6 Measure lower limits for each parameter (amplitude or frequency) by decreasing the measured input in equal decrements, one value at a time (for example, 10 dB changes) and compare the two waveforms as described in 7.8.2.4. The threshold may need to be adjusted to allow the system to be triggered by the simulator.

7.8.2.7 Perform this procedure for each channel in the AE system.