

INTERNATIONAL STANDARD

IEC 61076-2-101

First edition
2003-10

Connectors for electronic equipment –

Part 2-101:

Circular connectors –

Detail specification for circular connectors M8 with screw- or snap-locking, M12 with screw-locking for low voltage applications

Connecteurs pour équipements électroniques –

Partie 2-101:

Connecteurs circulaires –

Spécification particulière pour les connecteurs circulaires M8 à vis ou à encliquetage, M12 à vis pour applications basse tension



Reference number
IEC 61076-2-101:2003(E)

Publication numbering

As from 1 January 1997 all IEC publications are issued with a designation in the 60000 series. For example, IEC 34-1 is now referred to as IEC 60034-1.

Consolidated editions

The IEC is now publishing consolidated versions of its publications. For example, edition numbers 1.0, 1.1 and 1.2 refer, respectively, to the base publication, the base publication incorporating amendment 1 and the base publication incorporating amendments 1 and 2.

Further information on IEC publications

The technical content of IEC publications is kept under constant review by the IEC, thus ensuring that the content reflects current technology. Information relating to this publication, including its validity, is available in the IEC Catalogue of publications (see below) in addition to new editions, amendments and corrigenda. Information on the subjects under consideration and work in progress undertaken by the technical committee which has prepared this publication, as well as the list of publications issued, is also available from the following:

- **IEC Web Site** (www.iec.ch)

- **Catalogue of IEC publications**

The on-line catalogue on the IEC web site (www.iec.ch/searchpub) enables you to search by a variety of criteria including text searches, technical committees and date of publication. On-line information is also available on recently issued publications, withdrawn and replaced publications, as well as corrigenda.

- **IEC Just Published**

This summary of recently issued publications (www.iec.ch/online_news/justpub) is also available by email. Please contact the Customer Service Centre (see below) for further information.

- **Customer Service Centre**

If you have any questions regarding this publication or need further assistance, please contact the Customer Service Centre:

Email: custserv@iec.ch
Tel: +41 22 919 02 11
Fax: +41 22 919 03 00

INTERNATIONAL STANDARD

IEC 61076-2-101

First edition
2003-10

Connectors for electronic equipment –

Part 2-101:

Circular connectors –

Detail specification for circular connectors M8 with screw- or snap-locking, M12 with screw-locking for low voltage applications

Connecteurs pour équipements électroniques –

Partie 2-101:

Connecteurs circulaires –

Spécification particulière pour les connecteurs circulaires M8 à vis ou à encliquetage, M12 à vis pour applications basse tension

© IEC 2003 — Copyright - all rights reserved

No part of this publication may be reproduced or utilized in any form or by any means, electronic or mechanical, including photocopying and microfilm, without permission in writing from the publisher.

International Electrotechnical Commission, 3, rue de Varembé, PO Box 131, CH-1211 Geneva 20, Switzerland
Telephone: +41 22 919 02 11 Telefax: +41 22 919 03 00 E-mail: inmail@iec.ch Web: www.iec.ch



Commission Electrotechnique Internationale
International Electrotechnical Commission
Международная Электротехническая Комиссия

PRICE CODE

X

For price, see current catalogue

CONTENTS

FOREWORD	5
1 General information	8
1.1 Scope	8
1.2 Recommended method of termination	8
1.3 Ratings and characteristics	8
1.4 Normative references	9
1.5 Marking	9
1.6 IEC Type designation	10
1.7 Ordering information	11
2 Technical information	11
2.1 Definitions	11
2.2 Survey of styles and variants	11
3 Dimensions	29
3.1 General	29
3.2 Interface dimensions	30
3.3 Engagement (mating) information	34
3.4 Gauges	36
4 Characteristics	37
4.1 Climatic category	37
4.2 Electrical	37
4.3 Mechanical	39
5 Test schedule	40
5.1 General	40
5.2 Test schedule	43
Annex A (informative) Steel conduit thread, sizes	49
Figure 1 – Tube insert mounting without thread, male contacts	12
Figure 2 – Tube insert mounting with thread M12x1, male contacts	12
Figure 3 – Fixed connector, square flange front mounting, male contacts	13
Figure 4 – Fixed connector, with wire ends, single hole mounting Pg9, male contacts	14
Figure 5 – Fixed connector, with wire ends, single hole mounting Pg13,5, male contacts	14
Figure 6 – Fixed connector with wire ends, single hole mounting Pg9, keyway orientation, male contacts	15
Figure 7 – Fixed connector, with wire ends, single hole rear mounting Pg13,5, keyway orientation, male contacts	15
Figure 8 – Fixed connector, with wire ends, single hole mounting Pg9, female contacts	16
Figure 9 – Fixed connector, with wire ends, single hole mounting Pg13,5, female contacts	16
Figure 10 – Fixed connector, with wire ends, single hole rear mounting Pg9 keyway orientation, female contacts	17
Figure 11 – Fixed connector, with wire ends, single hole rear mounting Pg13,5, keyway orientation, female contacts	17
Figure 12 – Rewireable connector, straight version, with locking nut, male contacts	18

Figure 13 – Rewireable connector, straight version, with locking nut, female contacts.....	19
Figure 14 – Rewireable connector, right angled version, with locking nut, male contacts.....	20
Figure 15 – Rewireable connector, right angled version, with locking nut, female contacts ...	20
Figure 16 – Non-rewireable connector, straight version, with locking nut, male contacts	21
Figure 17 – Non-rewireable connector, straight version, with locking nut, female contacts	21
Figure 18 – Non-rewireable connector, right angled version, with locking nut, male contacts.....	22
Figure 19 – Non-rewireable connector, right angled version, with locking nut, female contacts.....	22
Figure 20 – Tube insert, mounting long version, male contacts dip solder	23
Figure 21 – Tube insert, mounting short version, male contacts dip solder	23
Figure 22 – Fixed connector with wire ends, single hole rear mounting, male contacts	24
Figure 23 – Fixed connector with wire ends, single hole rear mounting, female contacts	24
Figure 24 – Rewireable connector, straight version, with locking nut, male contacts.....	25
Figure 25 – Rewireable connector, straight version, with locking nut, female contacts.....	25
Figure 26 – Rewireable connector, right angled version, with locking nut, male contacts.....	26
Figure 27 – Rewireable connector, right angled version, with locking nut, female contacts	26
Figure 28 – Non-rewireable connector, straight version, snap locking, male contacts	27
Figure 29 – Non-rewireable connector, straight version, snap locking, female contacts	27
Figure 30 – Non-rewireable connector, angled version, snap locking, female contacts	27
Figure 31 – Non-rewireable connector, straight version, with locking nut, male contacts	28
Figure 32 – Non-rewireable connector, straight version, with locking nut, female contacts	28
Figure 33 – Non-rewireable connector, angled version, with locking nut, male contacts.....	29
Figure 34 – Non-rewireable connector, angled version with locking nut, female contacts.....	29
Figure 35 – Type D – Front view of connectors	30
Figure 36 – Type D – Contact marking of connectors	31
Figure 37 – Type E – Front view of connectors.....	32
Figure 38 – Type E – Contact marking of connectors	33
Figure 39 – Engagement (mating) information	34
Figure 40 – Gauge dimensions.....	37
Figure 41 – Contact resistance arrangement.....	41
Figure 42 – Dynamic stress test arrangement	42
Figure A.1 – Dimensions Pg thread	49
Table 1 – Styles of fixed connectors type D.....	11
Table 2 – Styles of free connectors type D	18
Table 3 – Styles of fixed connectors type E	23
Table 4 – Styles of free connectors type E	25
Table 5 – Dimensions of connectors type D in mated and locked position	35
Table 6 – Dimensions of connectors type E in mated and locked position.....	36
Table 7 – Gauges.....	37
Table 8 – Climatic Category	37
Table 9 – Rated voltage – Impulse voltage – Pollution degree connectors type D.....	38
Table 10 – Rated voltage – Impulse voltage – Pollution degree connectors type E.....	38

Table 11 – Voltage proof connectors type D	38
Table 12 – Voltage proof connectors type E	39
Table 13 – Number of mechanical operations	40
Table 14 – Insertion and withdrawal forces	40
Table 15 – Number of test specimens	41
Table 16 – Test group P	43
Table 17 – Test group AP	44
Table 18 – Test group BP	46
Table 19 – Test group CP	47
Table 20 – Test group DP	47
Table 21 – Test group EP	48
Table A.1 – Dimensions	50

Withholding

iTech Standards
(<https://standards.iteh.ai>)
Document Preview

[IEC 61076-2-101:2003](https://standards.iteh.ai/catalog/standards/iec/906485ef-c2f3-4e58-b8ab-921bc9923604/iec-61076-2-101-2003)

<https://standards.iteh.ai/catalog/standards/iec/906485ef-c2f3-4e58-b8ab-921bc9923604/iec-61076-2-101-2003>

INTERNATIONAL ELECTROTECHNICAL COMMISSION

CONNECTORS FOR ELECTRONIC EQUIPMENT –**Part 2-101: Circular connectors –
Detail specification for circular connectors M8
with screw- or snap-locking, M12 with screw-locking
for low voltage applications**

FOREWORD

- 1) The International Electrotechnical Commission (IEC) is a worldwide organization for standardization comprising all national electrotechnical committees (IEC National Committees). The object of IEC is to promote international co-operation on all questions concerning standardization in the electrical and electronic fields. To this end and in addition to other activities, IEC publishes International Standards, Technical Specifications, Technical Reports, Publicly Available Specifications (PAS) and Guides (hereafter referred to as "IEC Publication(s)"). Their preparation is entrusted to technical committees; any IEC National Committee interested in the subject dealt with may participate in this preparatory work. International, governmental and non-governmental organizations liaising with the IEC also participate in this preparation. IEC collaborates closely with the International Organization for Standardization (ISO) in accordance with conditions determined by agreement between the two organizations.
- 2) The formal decisions or agreements of IEC on technical matters express, as nearly as possible, an international consensus of opinion on the relevant subjects since each technical committee has representation from all interested IEC National Committees.
- 3) IEC Publications have the form of recommendations for international use and are accepted by IEC National Committees in that sense. While all reasonable efforts are made to ensure that the technical content of IEC Publications is accurate, IEC cannot be held responsible for the way in which they are used or for any misinterpretation by any end user.
- 4) In order to promote international uniformity, IEC National Committees undertake to apply IEC Publications transparently to the maximum extent possible in their national and regional publications. Any divergence between any IEC Publication and the corresponding national or regional publication shall be clearly indicated in the latter.
- 5) IEC provides no marking procedure to indicate its approval and cannot be rendered responsible for any equipment declared to be in conformity with an IEC Publication.
- 6) All users should ensure that they have the latest edition of this publication.
- 7) No liability shall attach to IEC or its directors, employees, servants or agents including individual experts and members of its technical committees and IEC National Committees for any personal injury, property damage or other damage of any nature whatsoever, whether direct or indirect, or for costs (including legal fees) and expenses arising out of the publication, use of, or reliance upon, this IEC Publication or any other IEC Publications.
- 8) Attention is drawn to the Normative references cited in this publication. Use of the referenced publications is indispensable for the correct application of this publication.
- 9) Attention is drawn to the possibility that some of the elements of this IEC Publication may be the subject of patent rights. IEC shall not be held responsible for identifying any or all such patent rights.

International Standard IEC 61076-2-101 has been prepared by subcommittee 48B: Connectors, of IEC technical committee 48: Electromechanical components and mechanical structures for electronic equipment.

The text of this standard is based on the following documents:

FDIS	Report on voting
48B/1362/FDIS	48B/1384/RVD

Full information on the voting for the approval of this standard can be found in the report on voting indicated in the above table.

This publication has been drafted in accordance with the ISO/IEC Directives, Part 2.

Future standards in this series will carry the new general title as cited above. Titles of existing standards in this series will be updated when a new edition is prepared.

The committee has decided that the contents of this publication will remain unchanged until 2005. At this date, the publication will be

- reconfirmed;
- withdrawn;
- replaced by a revised edition, or
- amended.

A bilingual edition of this standard may be issued at a later date.

Withdrawing

iTeh Standards
(<https://standards.iteh.ai>)
Document Preview

[IEC 61076-2-101:2003](https://standards.iteh.ai/collections/standards/iec/906485ef-c2f3-4e58-b8ab-921bc9923604/iec-61076-2-101-2003)

<https://standards.iteh.ai/collections/standards/iec/906485ef-c2f3-4e58-b8ab-921bc9923604/iec-61076-2-101-2003>

**CONNECTORS FOR ELECTRONIC EQUIPMENT –
Part 2-101: Circular connectors –
Detail specification for circular connectors M8
with screw- or snap-locking, M12 with screw-locking
for low voltage applications**

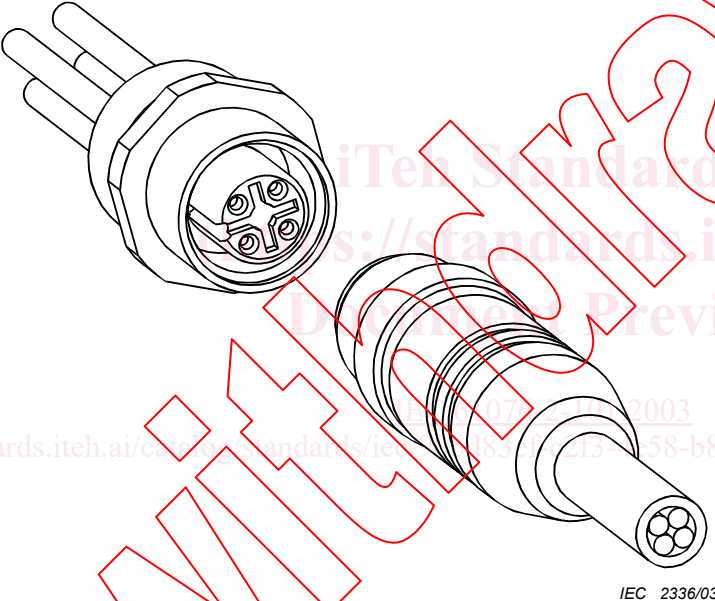
INTERNATIONAL ELECTROTECHNICAL COMMISSION IEC SC 48B – Connectors	IEC 61076-2-101
ELECTRONIC COMPONENTS in accordance with IEC 61076-1	Blank detail specification IEC 61076-2-001
 <p align="right">IEC 2336/03</p>	Circular connectors M8/Ø8 mm 3 and 4 poles M12 2 to 8 poles Pin and socket connectors Rewireable – Non-rewireable
	Free cable connectors Straight and right angle connectors Fixed connectors Flange mounting Single hole mounting Pin sockets
Information on the availability of components qualified to this detail specification is given in the qualified products list.	

1 General information

Throughout this detail specification dimensions are in mm.

1.1 Scope

This part of IEC 61076 describes circular connectors for use in industrial control circuits devices like switchgear and controlgear. These connectors consist of fixed and free connectors either rewirable or non-rewirable, M8 with screw-locking or \varnothing 8 mm with snap-locking, M12 with screw-locking.

Male connectors have round contacts \varnothing 0,8 mm and \varnothing 1,0 mm.

1.2 Recommended method of termination

The contact terminations shall be of the following types: screw, crimp, solder, insulation piercing or insulation displacement.

1.2.1 Number of contacts or contact cavities

Connectors type D	M12	2 to 8 contacts
Connectors type E	M8/ \varnothing 8 mm	3 and 4 contacts

1.3 Ratings and characteristics

Rated voltage:	Connectors type D:	2 to 4 poles	250 V AC/DC
		5 poles	60 V AC/DC
		6 to 8 poles	30 V AC/DC

Connectors type E:	3 poles	60 V AC/DC
	4 poles	30 V AC/DC

Current rating:	Type D	2 to 5 poles	= 4 A
		6 to 8 poles	= 2 A
	Type E	3 poles	= 3 A
		4 poles	= 3 A

Insulation resistance: $> 10^8 \Omega$

Climatic category: see 4.1 and Table 8

Contact spacing: see Clause 3

Information on the availability of components or manufacturer who have components qualified to this detail specification is given in the qualified products list.

1.4 Normative references

The following referenced documents are indispensable for the application of this document. For dated references, only the edition cited applies. For undated references, the latest edition of the referenced document (including any amendments) applies.

IEC 60050-581, *International Electrotechnical Vocabulary – Electromechanical components for electronic equipment*

IEC 60068-1:1988, *Environmental testing – Part 1: General and guidance*
Amendment 1 (1992)

IEC 60352 (all parts), *Solderless connections*

IEC 60512 (all parts), *Connectors for electronic equipment – Tests and measurements*

IEC 60512-1-100, *Connectors for electronic equipment – Tests and measurements – Part 1-100: General – Applicable publications*

IEC 60529:1989, *Degrees of protection provided by enclosures (IP code)*

IEC 60664-1:1992, *Insulation coordination for equipment within low-voltage systems – Part 1: Principles, requirements and tests*

IEC 60998-2-1, *Connecting devices for low-voltage circuits for household and similar purposes – Part 2-1: Particular requirements for connecting devices as separate entities with screw-type clamping units*

IEC 60999 (all parts), *Connecting devices – Electrical copper conductors – Safety requirements for screw-type and screwless-type clamping units*

IEC 61076-1:1995, *Connectors with assessed quality, for use in d.c., low frequency analogue and in digital high speed data applications – Part 1: Generic specification*
Amendment 1 (1996)

IEC 61076-2, *Connectors for use in d.c., low-frequency analogue and digital high speed data applications – Part 2: Circular connectors with assessed quality – Sectional specification*

IEC 61076-2-001, *Connectors for electronic equipment – Part 2-001: Circular connectors – Blank detail specification*

ISO 1302, *Geometrical Product Specifications (GPS) – Indication of surface texture in technical product documentation*

1.5 Marking

The marking of the connector and the package shall be in accordance with 2.6 of IEC 61076-2.

1.6 IEC Type designation

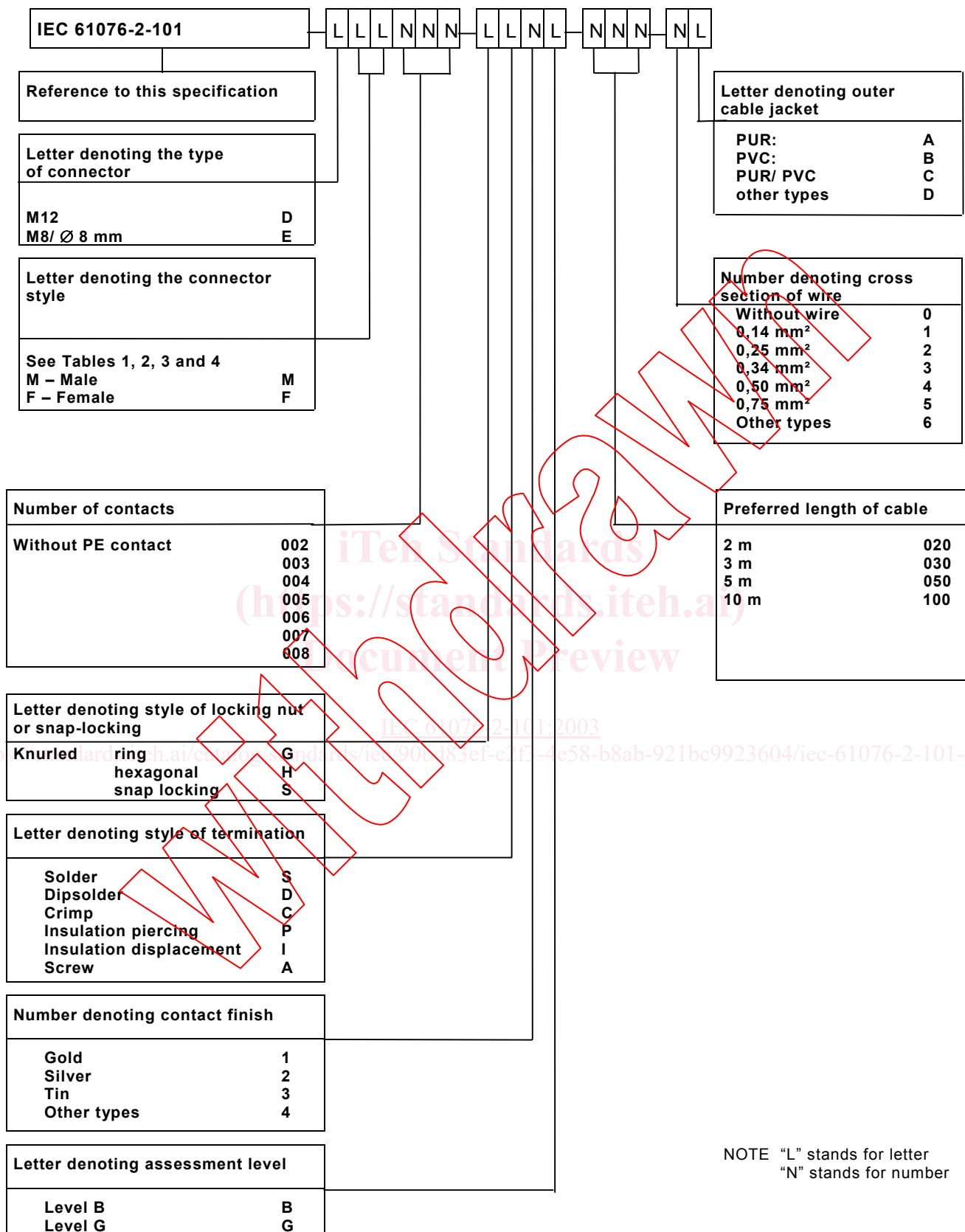

1.7 Ordering information

For ordering connectors to this detail specification, the type designation described in 1.6 shall be used.

EXAMPLE 1

non-rewireable free connector.

DMF 004 – G1B – 020 – 3A

Free connector M12 Style MF, non-rewireable, right angled version with female contacts, 4 poles, with knurled ring, gold contact finish, assessment level B, cable length 2,0 m, cross section of wire 0,34 mm², PUR cable jacket.

EXAMPLE 2

rewireable free connector.

DKM 004 – GC3B

Free connector M12 Style KM, rewireable, right angled version with female contacts, with 4 poles, with knurled ring, crimp terminals, tin contact finish, assessment level B.

2 Technical information

Dimensions in mm.

2.1 Definitions

For the purposes of this part of IEC 61076, the terms and definitions given in IEC 581 apply.

2.2 Survey of styles and variants

2.2.1 Fixed connectors type D

Type D denotes M12 connectors. For interface dimensions, see 3.2.1.

Table 1 – Styles of fixed connectors type D

Style	Description
AM	Tube insert mounting without thread, male contacts
BM	Tube insert mounting with thread M12x1, male contacts
DM	Fixed connector, square flange front mounting, male contacts
EM	Fixed connector, with wire ends, single hole mounting Pg9, ¹⁾ , male contacts
FM	Fixed connector, with wire ends, single hole mounting Pg13,5, ¹⁾ , male contacts
GM	Fixed connector, with wire ends, single hole mounting Pg9, ¹⁾ , keyway orientation, male contacts
HM	Fixed connector, with wire ends, single hole rear mounting Pg13,5, ¹⁾ , keyway orientation, male contacts
EF	Fixed connector, with wire ends, single hole mounting Pg9, ¹⁾ , female contacts
FF	Fixed connector, with wire ends, single hole mounting Pg13,5, ¹⁾ , female contacts
GF	Fixed connector, with wire ends, single hole rear mounting Pg9, ¹⁾ , keyway orientation, female contacts
HF	Fixed connector, with wire ends, single hole rear mounting Pg13,5, ¹⁾ , keyway orientation, female contacts

¹⁾ For Pg dimensions, see Annex A.

2.2.1.1 Style AM

Dimensions in mm

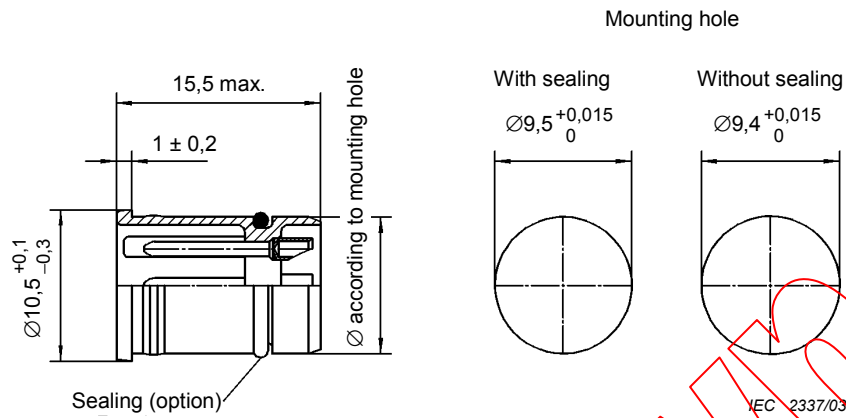

Figure 1 – Tube insert mounting without thread, male contacts

2.2.1.2 Style BM

Dimensions in mm

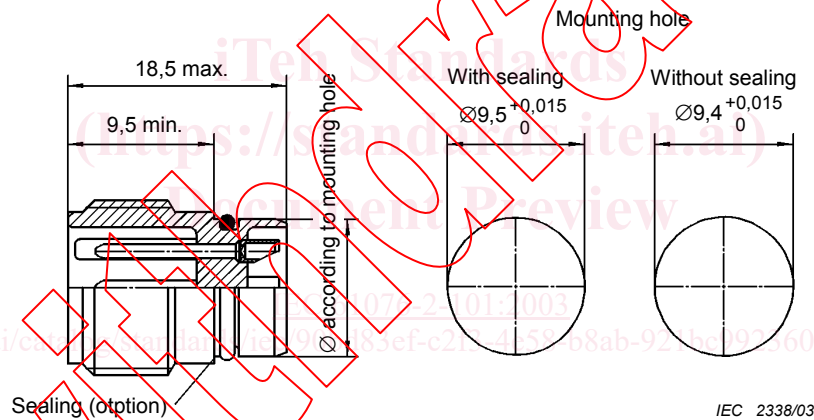

Figure 2 – Tube insert mounting with thread M12x1, male contacts