



Standard Specification for Manhole Cover Assembly, Bolted, Raised, Oiltight and Watertight¹

This standard is issued under the fixed designation F 1143; the number immediately following the designation indicates the year of original adoption or, in the case of revision, the year of last revision. A number in parentheses indicates the year of last reapproval. A superscript epsilon (ϵ) indicates an editorial change since the last revision or reapproval.

1. Scope

1.1 This specification provides design and construction criteria for a raised, bolted, oiltight, and watertight manhole cover assembly.

1.2 The manhole cover assemblies depicted in this specification are for use in decks or bulkheads in which the manhole cover assemblies must be of the raised type. Manhole cover shall be complete with coaming, gasket, welded studs or bolts, washers, and nuts.

1.3 Determination of the use of handles will be as specified in the ordering information.

1.4 The values stated in inch-pound units are to be regarded as the standard. The values given in parentheses are for information only.

1.5 This specification is not applicable to certain hazardous cargos (see Section 46 CFR 153.254 and 46 CFR 154.340).

1.6 This specification provides design and construction for manhole cover assemblies subjected to lateral pressures such as resulting from vehicle loads or hydrostatic pressures. Where manhole cover assemblies are subjected to primary or cyclic loads, other reinforcement or construction criteria may be necessary to integrate the manhole assembly with the required structural reinforcement for openings in decks or bulkheads. Design of the manhole cover assembly for primary or cyclic loads is beyond the scope of this specification.

2. Referenced Documents

2.1 ASTM Standards:

- A 36/A 36M Specification for Structural Steel²
- A 131/A 131M Specification for Structural Steel for Ships²
- A 153/A 153M Specification for Zinc Coating (Hot-Dip) on Iron and Steel Hardware³
- B 36/B 36M Specification for Brass Plate, Sheet, Strip, and Rolled Bar⁴
- D 2000 Classification System for Rubber Products in Auto-

motive Applications⁵

F 783 Specification for Staple, Handgrab, Handle, and Stirrup Rung⁶

2.2 ANSI Standards:

- B1.1 Unified Inch Screw Threads⁷
- ANSI Y14.5M Dimensioning and Tolerancing⁷
- B18.2.1 Square and Hex Bolts and Screws, Inch Series⁷
- 2.3 American Bureau of Shipping Standard: Rules for Building and Classing Steel Vessels⁸
- 2.4 Steel Structures Painting Council Standard: SP-10 Surface Preparation Specification No. 10⁹
- 2.5 Code of Federal Regulations Standard: CFR 46 Code of Federal Regulations¹⁰

3. Terminology

3.1 Definitions:

- 3.1.1 *manhole*—an accessway located in a tank structure.
- 3.1.2 *raised*—manhole cover seat is located on an angle or flat bar coaming which protrudes from the tank structure into the space from which it is accessed.

4. Classification

4.1 *Type I*—15- by 23-in. (381- by 584-mm) size of access opening. *Type II*—18- by 24-in. (457- by 610-mm) size of access opening.

4.2 *Grade 1*— $\frac{1}{4}$ -in. (6.35-mm) thick cover plate. *Grade 2*— $\frac{3}{8}$ -in. (9.5-mm) thick cover plate. *Grade 3*— $\frac{1}{2}$ -in. (13-mm) thick cover plate.

4.3 *Class A Manhole Cover Assemblies*—Class A manhole cover assemblies shall be abrasive blasted to near white metal in accordance with SSPC SP-10 and a commercial marine quality nonhazardous corrosion-inhibiting and oil-resistant primer coating be applied for protection for a period of one year during shipping and in shipyard handling.

4.4 *Class B Manhole Cover Assemblies*—Class B manhole

⁵ Annual Book of ASTM Standards, Vol 09.02.

⁶ Annual Book of ASTM Standards, Vol 01.07.

⁷ Available from American National Standards Institute, 11 W. 42nd St., 13th Floor, New York, NY 10036.

⁸ Available from American Bureau of Shipping, 45 Eisenhower Dr., Paramus, NJ 07652.

⁹ Available from Steel Structures Painting Council, 4400 Fifth Ave., Pittsburgh, PA 15213.

¹⁰ Available from Superintendent of Documents, Government Printing Office, Washington, DC 20402.

¹ This specification is under the jurisdiction of ASTM Committee F-25 on Ships and Marine Technology and is the direct responsibility of Subcommittee F25.03 on Outfitting.

Current edition approved Aug. 10, 1998. Published December 1998. Originally published as F 1143 – 88. Last previous edition F 1143 – 90.

² Annual Book of ASTM Standards, Vol 01.04.

³ Annual Book of ASTM Standards, Vol 01.06.

⁴ Annual Book of ASTM Standards, Vol 02.01.



cover assemblies shall be galvanized in accordance with Specification A 153/A 153M.

5. Ordering Information

5.1 The purchaser's ordering information shall include the following information:

- 5.1.1 ASTM designation and year of issue,
- 5.1.2 Type (see 4.1),
- 5.1.3 Grade (see 4.2),
- 5.1.4 Class (see 4.3 and 4.4),
- 5.1.5 Shape (rectangular or oval) (see Fig. 1 and Fig. 2),
- 5.1.6 Quantity,
- 5.1.7 *Remarks*—Handles (are/are not) required, and
- 5.1.8 *Approval*—Classification society approval (is/is not) required.
- 5.1.9 Gasket, if other than specified (see 6.7).

6. Materials and Manufacture

6.1 Plate for the cover to be of Specifications A 36/A 36M or A 131/A 131M steel.

6.2 Coaming to be of Specifications A 36/A 36M or A 131/A 131M steel.

6.3 Round bar for the handle shall be in accordance with Specification F 783, Type A.

6.4 Bolts shall be $\frac{3}{4}$ in. (19.05 mm) by $2\frac{1}{4}$ in. (57 mm) long. Welded studs shall be $\frac{3}{4}$ in. (19.05 mm) by $1\frac{3}{4}$ in. (44.4 mm) long. Bolts or welded studs shall be manufactured of ordinary steel to commercial standards. Threads shall be the coarse thread series as specified in the latest issue of ANSI B1.1.

6.5 Washers shall be ANSI B18.2.1 Type A, $\frac{3}{4}$ -in. (19.05-mm) washer, 2-in. (50.8-mm) by 0.148-in. (3.8-mm) thick standard flat manufactured of yellow brass, Specification B 36/B 36M.

6.6 Heavy hex nuts shall be $\frac{3}{4}$ in. (19.05 mm) and manufactured of yellow brass, Specification B 36/B 36M. Threads in nuts shall conform to the dimensions for coarse threads with tolerances prescribed in ANSI B1.1. The nut shall conform to dimensions prescribed in ANSI B18.2.1.

6.7 Unless otherwise specified in ordering information, gasket shall be rubber, $\frac{3}{16}$ in. (4.8 mm) thick, 50 ± 5 durometer, or other such classification society rules as may be applicable. Manhole cover assemblies for government application see Annex A2 for type of gaskets.

6.8 Welding to conform to the latest issue of the American Bureau of Shipping Rules per Classification D 2000 5BC507 A14 E034.

6.9 Details of bolted manhole cover assembly is shown in Fig. 1 and Fig. 2.

7. Dimensions and Permissible Variations

7.1 Dimensions of manhole assembly shall be as indicated in Table 1 and Table 2.

7.2 For plating up to and including $\frac{1}{4}$ -in. (6.4-mm) thickness, use cover plate of $\frac{1}{4}$ -in. (6.4-mm) thickness. Plating over $\frac{1}{4}$ -in. (6.4-mm) up to, and including $\frac{3}{8}$ -in. (9.5-mm) thickness, use cover plate of $\frac{3}{8}$ -in. (9.5-mm) thickness. Plating over $\frac{3}{8}$ -in. (9.5-mm) thickness, use cover plate of $\frac{1}{2}$ -in. (12.7-mm) thickness.

8. Workmanship, Finish, and Appearance

8.1 Items produced under this specification shall be free of splinters, sharp edges, burrs, projections, and weld spatters.

9. Sampling

9.1 For orders for one or two manhole cover assemblies, each manhole cover assembly shall be inspected.

9.2 For orders for three to ten manhole cover assemblies, two manhole cover assemblies shall be selected at random. If any one of them fails to meet requirements, then all manhole cover assemblies in the order shall be inspected.

9.3 For orders for more than ten manhole cover assemblies, they shall be separated into groups of ten (or fraction thereof) for sampling purposes.

10. Inspection and Testing

10.1 *Responsibility*—Unless otherwise in the order, the manufacturer is responsible for the performance of all inspection and testing specified herein. The manufacturer may use his own facilities or any commercial facility acceptable to the purchaser. The purchaser reserves the right to perform any of the inspections and tests set forth where such are deemed necessary to assure that supplies conform to prescribed requirements. Nonconforming manhole cover assemblies shall not be offered for delivery.

10.2 *Inspection*—The dimensions of the manhole cover assembly and its components shall be checked to ensure that they are within specified tolerances.

10.3 *Test Method*—Each manhole cover assembly shall be designed to the pressure listed in Table 1 and Table 2 and tested to a pressure equal to 1.5 times the design pressure. The test pressure shall be held for a minimum of 5 min. There shall be no visible sign of leakage, permanent deformation, or other indications of structural failure of the manhole cover assembly.

10.3.1 Before delivery, the manhole cover assemblies shall be certified as to their watertight and oiltight integrity. Groups of manhole cover assemblies whose representative samples pass the tightness test shall be certified for watertight and oiltight integrity to their design pressure.

11. Product Marking

11.1 Each manhole cover assembly shall be marked with the purchase order number. Item number from purchase order, ASTM designation number, type, grade, class, and manufacturer's name. Marking may be by paint, stencil, or weather-proof tag.

12. Packaging and Package Marking

12.1 Unless otherwise specified, packaging shall conform to the manufacturer's normal commercial practice, and in such a manner that will ensure acceptance by common carrier and afford protection against physical damage during shipment. Shipping containers shall conform to carrier regulations as applicable to the mode of transportation.

13. Keywords

13.1 bulkhead; decks; manhole cover; manhole cover assembly; marine technology; ships

F 1143

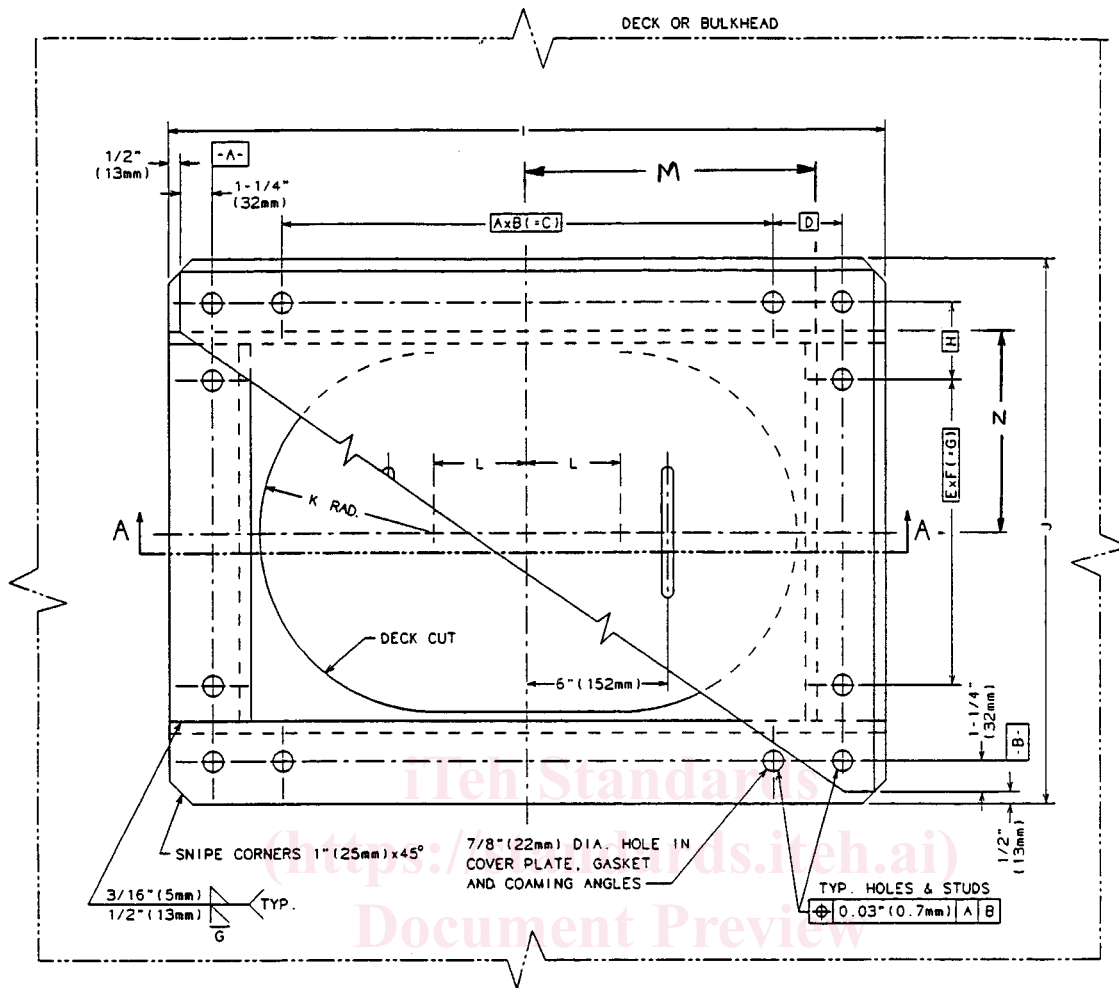

ASTM F1143-98

<https://standards.iteh.ai/catalog/standards/sist/26b056-2761-4a5e-8d1a-85460708ed56/astm-f1143-98>

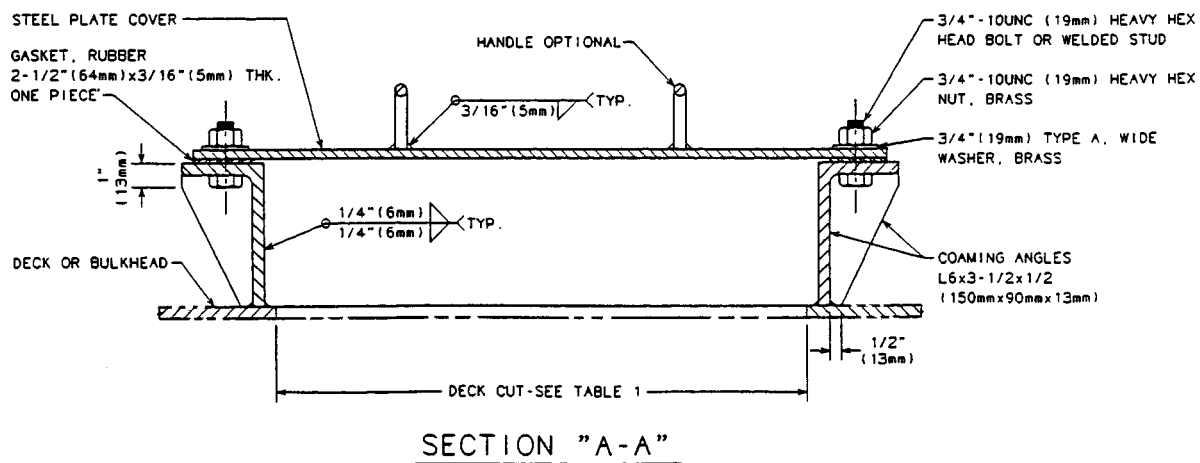

NOTE 1—See Table 1 for manhole cover assembly dimensions.
1 in. = 25.4 mm.

FIG. 1 Rectangular Manhole Cover Assembly, Raised, Bolted, Oiltight and Watertight

F 1143

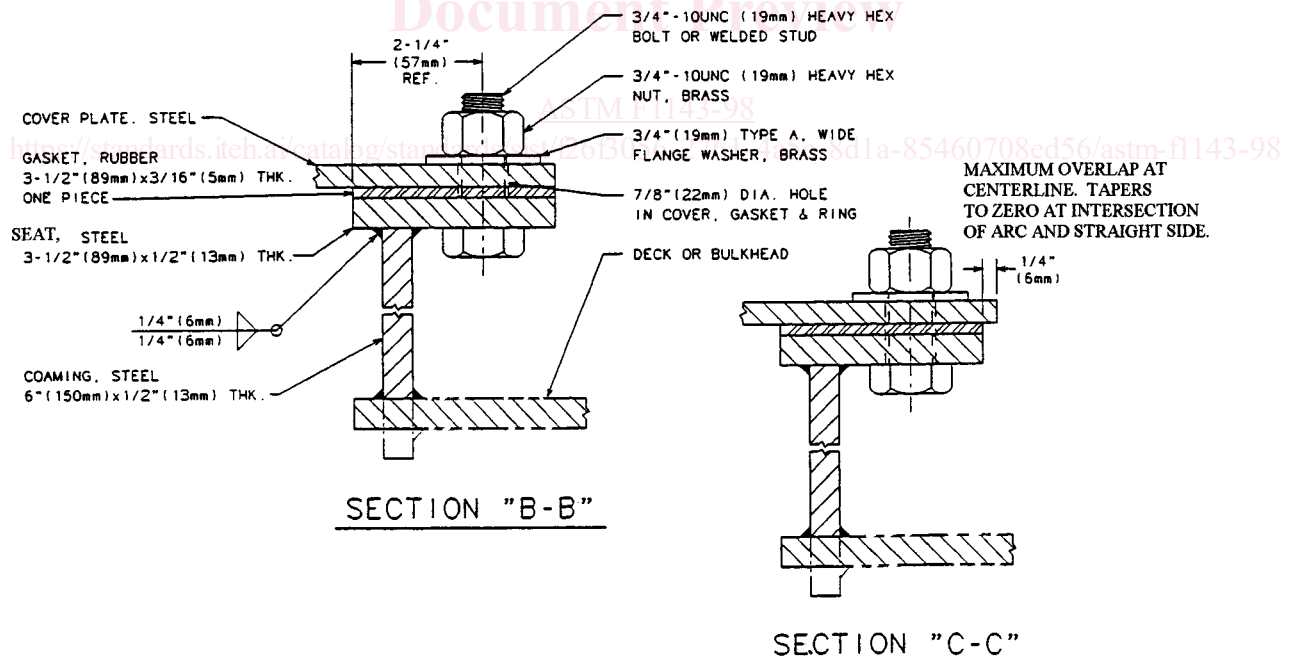
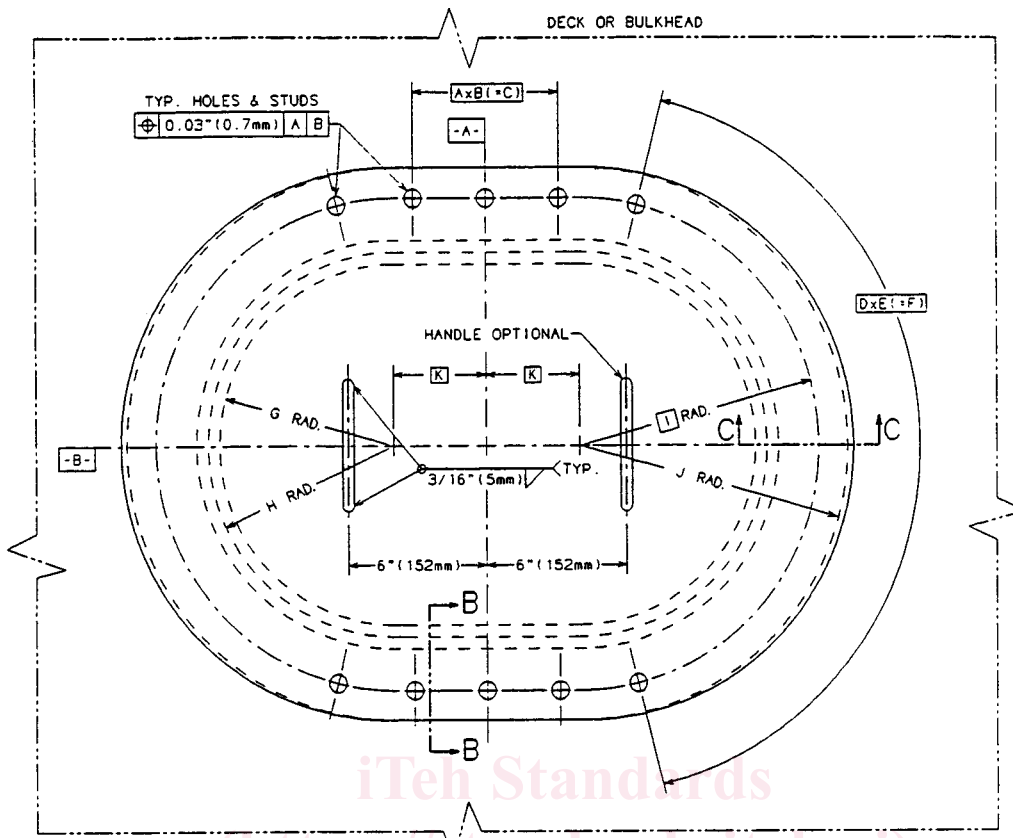

NOTE 1—See Table 2 for manhole cover assembly dimensions.
 1 in. = 25.4 mm.

FIG. 2 Oval Manhole Cover Assembly, Raised, Bolted, Oiltight and Watertight