



Designation: D7551 – 10 (Reapproved 2015)

Standard Test Method for Determination of Total Volatile Sulfur in Gaseous Hydrocarbons and Liquefied Petroleum Gases and Natural Gas by Ultraviolet Fluorescence¹

This standard is issued under the fixed designation D7551; the number immediately following the designation indicates the year of original adoption or, in the case of revision, the year of last revision. A number in parentheses indicates the year of last reapproval. A superscript epsilon (ϵ) indicates an editorial change since the last revision or reapproval.

1. Scope

1.1 This test method covers the determination of total volatile sulfur in gaseous hydrocarbons, Liquefied Petroleum Gases (LPG) and Liquefied Natural Gas (LNG). It is applicable to analysis of natural gaseous fuels, process intermediates, final product hydrocarbons and generic gaseous fuels containing sulfur in the range of 1 to 200 mg/kg. Samples can also be tested at other total sulfur levels using either pre-concentration methods or sample dilution using a diluent gas. The methodology for pre-concentration and dilution techniques is not covered in this test method. The precision statement does not apply if these techniques are used in conjunction with this test method. The diluent gas, such as UHP nitrogen, zero nitrogen or zero air, shall not have a significant total sulfur concentration.

1.2 This test method may not detect sulfur compounds that do not volatilize under the conditions of the test.

1.3 This test method covers the laboratory determination and the at-line/on-line determination of total volatile sulfur in gaseous fuels, LPG, and LNG.

1.4 This test method is applicable for total volatile sulfur determination in gaseous hydrocarbons, LPG, and LNG containing less than 0.35 mole % halogen(s).

1.5 The values stated in SI units are to be regarded as standard. No other units of measurement are included in this standard.

1.6 *This standard does not purport to address all of the safety concerns, if any, associated with its use. It is the responsibility of the user of this standard to establish appropriate safety and health practices and determine the applicability of regulatory limitations prior to use.* See Sections 4.1, 7.3, 7.4, 11.2, and Section 8.

2. Referenced Documents

2.1 ASTM Standards:²

- D1070 Test Methods for Relative Density of Gaseous Fuels
- D1072 Test Method for Total Sulfur in Fuel Gases by Combustion and Barium Chloride Titration
- D1265 Practice for Sampling Liquefied Petroleum (LP) Gases, Manual Method
- D3588 Practice for Calculating Heat Value, Compressibility Factor, and Relative Density of Gaseous Fuels
- D3609 Practice for Calibration Techniques Using Permeation Tubes
- D4150 Terminology Relating to Gaseous Fuels
- D4177 Practice for Automatic Sampling of Petroleum and Petroleum Products
- D4784 Specification for Liquefied Natural Gas Density Calculation Models
- D5287 Practice for Automatic Sampling of Gaseous Fuels
- D5503 Practice for Natural Gas Sample-Handling and Conditioning Systems for Pipeline Instrumentation (Withdrawn 2017)³
- D5504 Test Method for Determination of Sulfur Compounds in Natural Gas and Gaseous Fuels by Gas Chromatography and Chemiluminescence
- D6228 Test Method for Determination of Sulfur Compounds in Natural Gas and Gaseous Fuels by Gas Chromatography and Flame Photometric Detection
- D6299 Practice for Applying Statistical Quality Assurance and Control Charting Techniques to Evaluate Analytical Measurement System Performance
- D7166 Practice for Total Sulfur Analyzer Based On-line/At-line for Sulfur Content of Gaseous Fuels
- E617 Specification for Laboratory Weights and Precision Mass Standards
- E691 Practice for Conducting an Interlaboratory Study to

¹ This test method is under the jurisdiction of ASTM Committee D03 on Gaseous Fuels and is the direct responsibility of Subcommittee D03.06.02 on Analysis of Minor Constituents by Gas Chromatography.

Current edition approved Nov. 1, 2015. Published December 2015. Originally approved in 2010. Last previous edition approved as D7551-10. DOI: 10.1520/D7551-10R15.

² For referenced ASTM standards, visit the ASTM website, www.astm.org, or contact ASTM Customer Service at service@astm.org. For *Annual Book of ASTM Standards* volume information, refer to the standard's Document Summary page on the ASTM website.

³ The last approved version of this historical standard is referenced on www.astm.org.

Determine the Precision of a Test Method

F307 Practice for Sampling Pressurized Gas for Gas Analysis

2.2 ASTM Manuals:⁴

ASTM MNL 7

2.3 GPA Standards:⁵

GPA 2166 Obtaining Natural Gas Samples for Analysis by Gas Chromatography

GPA 2174 Obtaining Liquid Hydrocarbon Samples for Analysis by Gas Chromatography

3. Terminology

3.1 Definitions:

For definitions of *at-line instrument* and *on-line instrument* see Terminology D4150.

3.2 Acronyms:

3.2.1 LNG—liquefied natural gas

3.2.2 LPG—liquefied petroleum gas

3.2.3 NIST—National Institute of Standards and Technology

3.2.4 NMI—Nederlands Meetinstituut

3.2.5 NTRM—NIST traceable reference material

3.2.6 QA—quality assurance

3.2.7 QC—quality control

3.2.8 SO₂—ground state sulfur dioxide

3.2.9 SO₂*—excited state sulfur dioxide

3.2.10 SO_x—sulfur oxides

3.2.11 SRM—standard reference material

3.2.12 UHP—ultra high purity

3.2.13 UV—ultraviolet

3.2.14 VSL—Van Swinden Laboratorium

4. Summary of Test Method

4.1 A gaseous sample is injected into the analyzer, either by a sample valve, direct injection at a constant flow rate, or by syringe. A LPG or LNG sample is vaporized in an appropriate expansion chamber and injected into the analyzer by a sample valve or a syringe or a sample valve connected to an expansion chamber. The gaseous sample then enters into a high temperature combustion tube where the sulfur-containing compounds in the sample are oxidized to SO₂. Water produced during the sample combustion is removed, as required, and the sample combustion gases are then exposed to a source of continuous or pulsed UV light. The SO₂ absorbs the energy from the UV light to form SO₂*. Fluorescence emitted from SO₂* as it returns to SO₂, is detected by a photomultiplier tube. The resulting signal is a measure of the sulfur contained in the sample. **Warning**—Exposure to excessive quantities of UV light is injurious to health. The operator shall avoid exposing any part of their person, especially their eyes, not only to direct UV light but also to secondary or scattered radiation that is present.

4.2 The design and installation details for the on-line/at-line process analyzer needs to conform to application-specific requirements including, but not limited to, acceptable design practices as described in Practice D7166, hazardous area classifications, safety practices, and regulatory requirements. Fig. 1 illustrates a general flow diagram applicable for an on-line/at-line process analyzer. Sample collection and conditioning, sample introduction and detection system are depicted. Modifications to meet site-specific and/or application specific requirements may be required.

5. Significance and Use

5.1 The sulfur content of gaseous hydrocarbons, LPG, and LNG used for fuel purposes contributes to total SO_x emissions and can lead to corrosion in engine and exhaust systems. Some process catalysts used in petroleum and chemical refining can be poisoned by trace amounts of sulfur-bearing materials in the feed stocks. This test method can be used to determine the total volatile sulfur content in process feeds, to control the total

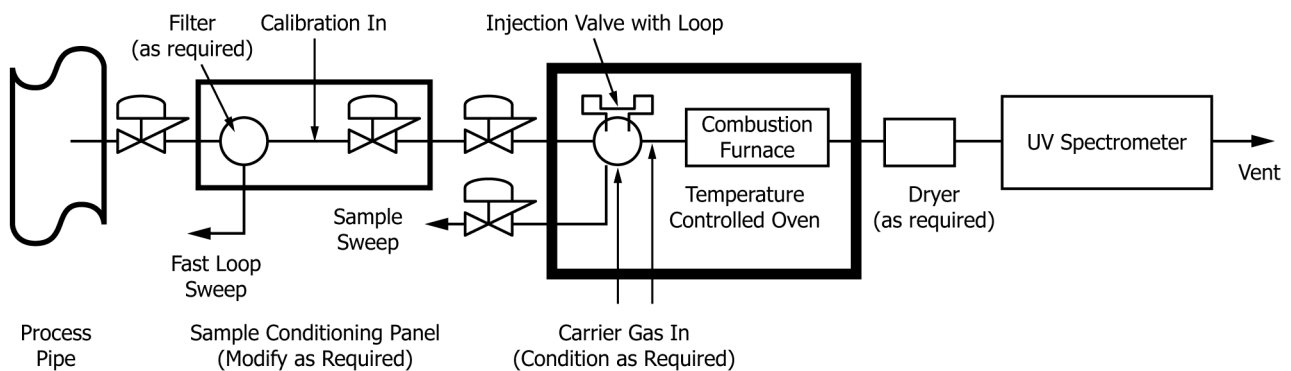

FIG. 1 General Flow Diagram—On-Line Analyzer

⁴ MNL 7A Manual on Presentation of Data and Control Chart Analysis, Seventh Edition, ASTM International, West Conshohocken, 2002.

⁵ Available from Gas Processors Association (GPA), 6526 E. 60th St., Tulsa, OK 74145, <http://www.gasprocessors.com>.

volatile sulfur content in finished products and, as applicable, to meet regulatory requirements. Practice **D1072** has previously been used for the measurement of total sulfur in gaseous fuels.

6. Apparatus

6.1 *Furnace*—An electric furnace held at a constant temperature in accordance with the analyzer manufacturer's recommendations (nominally 1000 to 1125°C) sufficient to oxidize the entire sample to carbon dioxide and water and oxidize the sulfur in the sample to SO₂.

6.2 *Combustion Tube*—A quartz tube constructed to allow the direct injection of the sample into the heated oxidation zone of the furnace by syringe or sample valve using either oxygen or air for the oxidation of the sample. Other tube materials suitable for use at the furnace operating conditions can be used so long as performance is not degraded. The oxidation section shall be large enough to ensure complete conversion of the sample to carbon dioxide and water and oxidize the sulfur in the sample to SO₂.

6.3 *Flow Control*—The apparatus shall be equipped with flow controllers capable of maintaining a constant volumetric flow rate of the carrier gases necessary for performing the total sulfur analysis.

6.4 *Drier*—The oxidation of the sample produces reaction products that include water vapor which, if in excess, must be removed prior to measurement by the detector. This can be accomplished with a membrane drying tube, or a permeation dryer that utilizes a selective capillary action for water removal.

6.5 *UV Fluorescence Detector*—A quantitative detector capable of measuring light emitted from the fluorescence of SO₂ generated by continuous or pulsed UV light.

NOTE 1—For an on-line analyzer, detection of uncombusted hydrocarbons in the UV Fluorescence Detector can be used to ensure complete conversion of the hydrocarbons to carbon dioxide and water and to minimize the potential for coke formation in the analytical system.

6.6 *Sample Inlet System*—Either of the following two types of sample inlet systems can be used.

6.6.1 *Sample Valve System*—The system provides a gas-sampling valve, or an LPG or LNG gas or liquid sampling valve with an expansion chamber, or both, with access to the inlet of the oxidation area. The system is swept by the carrier gas at the manufacturer's recommended flow rate.

6.6.2 *Sample Injection*—The sample inlet system for gaseous samples shall be capable of allowing the quantitative delivery of the material to be analyzed into an inlet carrier stream which directs the sample into the oxidation zone at a controlled and repeatable rate. For a laboratory analysis, a syringe drive mechanism that discharges the sample from the syringe at a rate of approximately 1 mL/s is required. For at line and on-line analysis a constant volumetric flow rate delivery device is used.

6.7 *Strip Chart Recorder*, equivalent electronic data logger, integrator or, recorder (optional).

7. Reagents

7.1 *Purity of Reagents*—Reagent grade chemicals shall be used in tests. Unless otherwise indicated, it is intended that all reagents shall conform to the specifications of the Committee on Analytical Reagents of the American Chemical Society, where such specifications are available. Other grades may be used, provided it is first ascertained that the reagent is of sufficiently high purity to permit its use without lessening the accuracy of the determination.

7.2 *Inert Gas*—Argon or helium only, high purity grade (that is, chromatography or zero grade), 99.998 % minimum purity, moisture 5 mg/kg maximum, as required.

7.3 *Oxygen*—High purity, that is, chromatography or zero grade, 99.75 % minimum purity, moisture 5 mg/kg maximum, dried over molecular sieves, as required. **Warning**—Oxygen vigorously accelerates combustion.

7.4 *Air*—Use dry, sulfur free air, that is, chromatography grade or zero grade, −40 °C dew point or lower, as required. Nitrogen/oxygen or helium/oxygen bottled gas blends containing no more than 30 % oxygen can also be used, as required. **Warning**—Never use pure oxygen as a substitute for air on analyzers designed to operate using air as a carrier gas.

7.5 *Calibration Standards*—Certified liquid or gas phase calibration standards from commercial sources or calibration gases prepared using certified permeation tube devices are required (see **Notes 2 and 3**). Accurate volatile sulfur containing standards are required for quantization of the volatile total sulfur content. Permeation tubes and compressed gas standards should be stable, of high purity, and of the highest available accuracy. Use of standards consisting of a sulfur compound and matrix similar to samples to be analyzed is recommended.

NOTE 2—Other sulfur sources and diluent materials can be used if precision and accuracy are not degraded. The use of solvent based calibration standards that are liquid at ambient temperatures and pressures is not recommended.

NOTE 3—Calibration standards are typically re-mixed and re-certified on a regular basis depending upon frequency of use and age. LPG calibration standards have a typical useful life of about 6–12 months.

NOTE 4—Enhanced oxygen containing combustion gasses, such as 30 % Oxygen balance Helium, Nitrogen, and/or Argon, can be used if precision and accuracy are not degraded.

NOTE 5—**Warning:** Compressed gas cylinders as well as sulfur compounds contained in permeation tubes may be flammable and harmful or fatal if ingested or inhaled. Permeation tubes and compressed gas standards should only be handled in well ventilated locations away from sparks and flames. Improper handling of compressed gas cylinders containing air, nitrogen, helium, or other gasses can result in unsafe conditions that can cause severe damage to equipment and significant harm, including death, to people. Rapid release of nitrogen or helium can result in asphyxiation. Compressed air supports combustion.

7.5.1 *Permeation Devices*—Standards containing volatile sulfur compounds can be made from permeation tubes, one for each selected sulfur species, gravimetrically calibrated and certified at a convenient operating temperature. With constant temperature, calibration gases covering a wide range of concentration can be generated by varying and accurately measuring the flow rate of diluent gas passing over the permeation tubes. These calibration gases can be used to calibrate the analyzer system.

7.5.1.1 *Permeation System Temperature Control*—Permeation devices are maintained at the calibration temperature within ± 0.1 °C.

7.5.1.2 *Permeation System Flow Control*—The permeation flow system measures diluent gas flow over the permeation tubes within an accuracy of ± 2 %.

7.5.1.3 Permeation tubes are inspected and weighed to the nearest 0.01 mg on at least a monthly basis using a balance calibrated against Specification E617 Class 1 weights or equivalent. Analyte concentration is calculated by weight loss and dilution gas flow rate as per Practice D3609. Permeation tubes are replaced when the liquid contents are reduced to less than 10 % of the initial mass or when the permeation surface is unusually discolored or otherwise compromised. Permeation tube disposal shall be in accordance with all applicable regulations.

7.5.2 *Compressed Gas Standards*—As an alternative to permeation tubes, blended gaseous standards containing volatile sulfur-containing compounds in nitrogen, helium methane or other base gas may be used. Care must be exercised when using compressed gas standards since they can introduce errors in measurement due to lack of uniformity in their manufacture or instability in their storage and use. The protocol for compressed gas standards contained in the appendix can be used to ensure uniformity in compressed gas standard manufacture and provide for traceability to a NIST or VSL (formerly NMI) reference material.

7.5.2.1 Compressed gas standard regulators must be appropriate for the delivery of sulfur containing gases and attached fittings must be passivated or inert to sulfur containing compounds in the compressed gas standards.

7.5.2.2 The following sulfur compounds, either singularly or together, are suggested for inclusion in a compressed gas standard:

Hydrogen sulfide (H_2S)
 Carbonyl sulfide (COS)
 Methyl mercaptan (CH_3SH)

7.5.2.3 The following substances can also be included, either singularly or together, in a compressed gas standard:

Ethyl mercaptan (CH_3CH_2SH)
 1-propanethiol ($CH_3CH_2CH_2SH$)
 2-propanethiol ($CH_3CHSHCH_3$)
 Dimethyl sulfide (CH_3SCH_3)

7.5.2.4 Other sulfur containing compounds can be used so long as the stability of the compressed gas standard is not compromised.

NOTE 6—**Warning:** The following compounds are not recommended for inclusion in mixed component standards due to their potential for promoting degradation:

Dimethyl disulfide (CH_3SSCH_3)
 Other disulfides

7.6 For calibration procedures utilizing one calibration standard, the sulfur concentration of the calibration standard should exceed the maximum sulfur content of the samples being analyzed. For laboratory analysis, the sulfur concentration in the test specimen shall be less than the concentration of the highest standard and greater than the concentration of the lowest standard used in the calibration. For at-line or on-line analysis, the concentration of the calibration standard is se-

lected in accordance with manufacturer's recommendations for the full-scale concentration range of the test samples to be analyzed. This value is typically between 80 and 100 % of the full scale concentration.

7.7 QC samples preferably contain one or more gas, LPG, or LNG materials with a known volatile total sulfur content that are stable and representative of the samples of interest. These QC samples are to be used to check the validity of the testing process as described in Section 14.

8. Hazards

8.1 Consult current OSHA regulations, suppliers' Material Safety Data Sheets, and local regulations for all materials used in this test method.

8.2 High temperature and flammable hydrocarbons under high pressures are employed in the test method. Exercise extra care when using flammable materials near the oxidative pyrolysis furnace.

9. Sampling

9.1 Laboratory Analyzers:

9.1.1 Obtain a sample in accordance with Practice D1265, D4177, D5287, D5503, F307, GPA 2174 or GPA 2166. Samples should be analyzed as soon as possible after taking from bulk supplies to prevent loss of sulfur or contamination due to exposure or contact with sample container.

9.1.2 If the sample is not used immediately, thoroughly mix it in its container prior to taking a test specimen. The use of segregated or specially treated sample containers that minimize sulfur compound loss can be required (see Note 7).

NOTE 7—Floating-piston cylinders can be used.

9.2 At-Line and On-Line Analyzers:

9.2.1 Sampling considerations for at-line and on-line analyzers can be found in Practice D7166.

10. Preparation of Apparatus

10.1 Place the analyzer into service in accordance with the manufacturer's instructions.

10.2 Adjust apparatus operational parameter settings, as required to meet the conditions suggested or specified by the manufacturer for the sample introduction method employed. Typical instrument parameters for laboratory instruments can be found in Table 1. Typical instrument parameters for on-line analyzers can be found in Table 2.

10.3 Adjust instrument sensitivity, baseline stability and perform instrument-blanking procedures following manufacturer's guidelines.

TABLE 1 Typical Operating Conditions Laboratory Instruments

Syringe Drive (Direct Inject) Drive Rate	1 mL/s
Sample Injection System carrier gas	25-30 mL/min
Furnace Temperature	1000-1125°C \pm 25°C
Furnace Oxygen Flowmeter Setting	375-450 mL/min
Inlet Oxygen Flowmeter Setting	10-30 mL/min
Inlet Carrier Flowmeter Setting	130-160 mL/min