



Designation: **D7110–14** **D7110 – 15**

Standard Test Method for Determining the Viscosity-Temperature Relationship of Used and Soot-Containing Engine Oils at Low Temperatures¹

This standard is issued under the fixed designation D7110; the number immediately following the designation indicates the year of original adoption or, in the case of revision, the year of last revision. A number in parentheses indicates the year of last reapproval. A superscript epsilon (ϵ) indicates an editorial change since the last revision or reapproval.

1. Scope*

1.1 This test method covers how to measure the apparent viscosity of used and soot-containing engine oils at low temperatures.

1.2 A shear rate of approximately $0.20.2 \text{ s}^{-1}$ is produced at shear stresses below 200 Pa. Apparent viscosity is measured continuously as the sample is cooled at a rate of $3^{\circ}\text{C}3^{\circ}\text{C}$ per hour over the range of -5°C to -40°C .

1.3 The measurements resulting from this test method are viscosity, the maximum rate of viscosity increase (Gelation Index) and the temperature at which the Gelation Index occurs.

1.4 Applicability to petroleum products other than engine oils has not been determined in preparing this test method.

1.5 The values stated in SI units are to be regarded as standard. No other units of measurement are included in this standard.

1.6 *This standard does not purport to address all of the safety concerns, if any, associated with its use. It is the responsibility of the user of this standard to establish appropriate safety and health practices and determine the applicability of regulatory limitations prior to use.*

2. Referenced Documents

2.1 *ASTM Standards:*²

D341 Practice for Viscosity-Temperature Charts for Liquid Petroleum Products

D3829 Test Method for Predicting the Borderline Pumping Temperature of Engine Oil

D4684 Test Method for Determination of Yield Stress and Apparent Viscosity of Engine Oils at Low Temperature

D4057 Practice for Manual Sampling of Petroleum and Petroleum Products

3. Terminology

3.1 *Definitions:*

3.1.1 *apparent viscosity, n*—the viscosity obtained by use of this test method.

¹ This test method is under the jurisdiction of ASTM Committee **D02** on Petroleum Products, Liquid Fuels, and Lubricants and is the direct responsibility of Subcommittee **D02.07** on Flow Properties.

Current edition approved Dec. 1, 2014/Dec. 1, 2015. Published January 2015/December 2015. Originally approved in 2005. Last previous edition approved in 2014/2014 as **D7110–05a** (2014)/**D7110 – 14**. DOI: [10.1520/D7110-14](https://doi.org/10.1520/D7110-14); [10.1520/D7110-15](https://doi.org/10.1520/D7110-15).

² For referenced ASTM standards, visit the ASTM website, www.astm.org, or contact ASTM Customer Service at service@astm.org. For *Annual Book of ASTM Standards* volume information, refer to the standard's Document Summary page on the ASTM website.

3.1.1.1 *Discussion*—

See **3.1.7** for definition of viscosity and units.

3.1.2 *digital contact thermometer (DCT), n*—an electronic device consisting of a digital display and associated temperature sensing probe.

3.1.2.1 *Discussion*—

This device consists of a temperature sensor connected to a measuring instrument; this instrument measures the temperature-dependent quantity of the sensor, computes the temperature from the measured quantity, and provides a digital output, or display of the temperature, or both. This device is sometimes referred to a digital thermometer.

*A Summary of Changes section appears at the end of this standard

3.1.3 *Newtonian oil, n*—an oil that, at a given temperature, exhibits a constant viscosity at all shear rates or shear stresses.

3.1.4 *non-Newtonian oil, n*—an oil that, at a given temperature, exhibits a viscosity that varies with shear stress or shear rate.

3.1.5 *shear rate, n*—velocity gradient perpendicular to the direction of flow.

3.1.5.1 *Discussion*—

The SI unit for shear rate is the reciprocal second (1/s; also s⁻¹).

3.1.6 *shear stress, n*—force per unit area in the direction of flow.

3.1.6.1 *Discussion*—

The SI unit for shear stress is the pascal (Pa).

3.1.7 *viscosity, n*—that property of a fluid which resists flow.

3.1.7.1 *Discussion*—

Viscosity is defined as the ratio of the applied shear stress (force causing flow) and the shear rate (resultant velocity of flow per unit distance from a stationary surface wet by the fluid). Mathematically expressed:

$$\text{viscosity} = \text{shear stress/shear rate or, symbolically, } \eta = \tau/\dot{\gamma} \quad (1)$$

in which the symbols in the second portion of [Eq 1](#) are defined by [3.1.5](#) and [3.1.6](#). The SI unit for viscosity used herein is millipascal seconds (mPa·s).

3.2 *Definitions of Terms Specific to This Standard:*

3.2.1 *air-binding oils, n*—those engine oils whose borderline pumping temperatures are determined by a combination of gelation and viscous flow.

3.2.2 *borderline pumping temperature, n*—that temperature at which an engine oil may have such poor flow characteristics that the engine oil pump may not be capable of supplying sufficient lubricant to the engine.

3.2.3 *calibration oil, n*—Newtonian oils developed and used to calibrate the viscometer drive module over the viscosity range required for this test method.

3.2.3.1 *Discussion*—

These calibration oils are specially blended to give sufficient sensitivity and range for the special viscometer head used.

3.2.4 *computer-programmed automated analysis, n*—use of techniques for acquiring analog data, converting these to digital values and using this information to automatically record and analyze torque output from the viscometer drive module and to render this information into tabular data and plotted relationships.

3.2.4.1 *analog-to-digital (A-D) converter, n*—a device for converting continuously produced electrical signals into discrete numerical values capable of being analyzed by computer technology.

3.2.5 *critical pumpability temperature, n*—the temperature at which an oil reaches a viscosity believed to be critical to limiting pumpability of the oil (see [3.2.6](#)).

3.2.6 *critical pumpability viscosity, n*—that apparent viscosity believed to cause pumpability problems in an engine.

3.2.7 *flow-limited oils, n*—those oils whose borderline pumping temperatures are determined by viscous flow.

3.2.8 *gelation, n*—a rheological condition of an oil characterized by a marked increase in flow resistance over and above the normal exponential increase of viscosity with decreasing temperature, particularly at lower shear stresses and temperatures.

3.2.8.1 *Discussion*—

Gelation has been attributed to a process of nucleation and crystallization of oil components and the consequent formation of a gel-like mass.³

3.2.9 *Gelation Index, n*—the maximum value of the incremental ratio:

³ *Symposium on Low Temperature Lubricant Rheology Measurement and Relevance to Engine Operation*, ASTM STP 1143, Ed. Robert B. Rhodes, ASTM, 1992.

$$-\frac{(\log \log \eta_1) - (\log \log \eta_2)}{(\log T_1 - \log T_2)} \quad (2)$$

in which η is dynamic viscosity and T is temperature in Kelvin over the temperature range scanned when the incremental decrease in temperature is $\pm 0.1 \text{ K}$.

3.2.9.1 Discussion—

The technique of deriving Gelation Index was first developed and practiced⁴ by collecting information from a strip-chart recording and applying the empirical MacCoull-Walther-Wright equation. For further information, see Appendix 1 of Viscosity-Temperature Charts D341.

3.2.10 Gelation Index reference oils, n —non-Newtonian oils chosen to give certain levels of Gelation Index as a check on instrument performance.

3.2.11 Gelation Index Temperature, n —the temperature in degrees Celsius at which the Gelation Index occurs.

3.2.12 pre-treatment sample heating bath, n —a water or air bath to heat the samples for ~~1.5 h~~ 1.5 h at $90 \text{ }^\circ\text{C} \pm 2 \text{ }^\circ\text{C}$ before testing.

3.2.13 programmable liquid cold bath, n —a liquid bath having a temperature controller capable of being programmed to run the calibration and the analysis portions of the test method.

3.2.14 temperature controller, n —a programmable device which, when properly programmed, ramps the temperature upward or downward at a chosen rate or series of steps while simultaneously controlling temperature excursions.

3.2.14.1 calibration program, n —a program to run the required series of temperatures at which the torque values necessary to calibrate the viscometer drive module are collected and analyzed.

3.2.14.2 test program, n —a program to run the test oil analysis at $\pm 0.3 \text{ }^\circ\text{C}/\text{h}$ temperature decrease.

3.2.14.3 hold program, n —a program to reach and hold the programmable liquid cold bath at $-5 \text{ }^\circ\text{C}$.

3.2.15 test cell, n —the combination of the rotor and stator. Critical elements of the test cell are sketched in Fig. 1.

⁴ Selby, T. W., "The Use of the Scanning Brookfield Technique to Study the Critical Degree of Gelation of Lubricants at Low Temperatures," SAE Paper 910746, Society of Automotive Engineers, 1991.

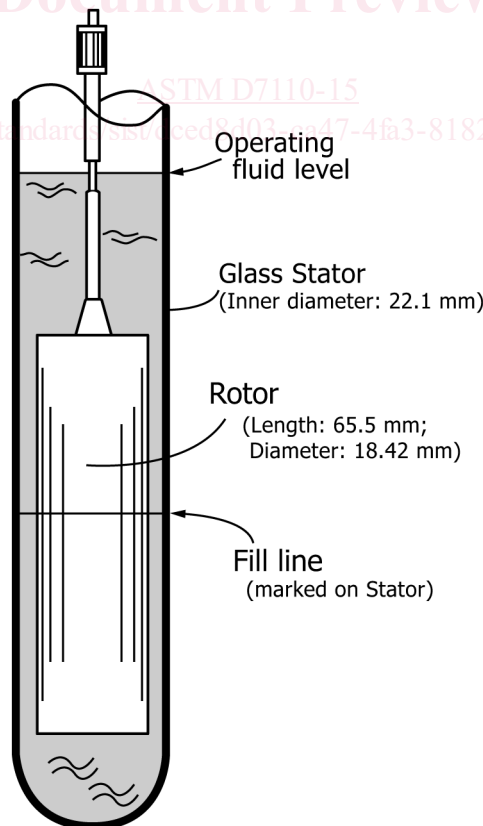

FIG. 1 Test Cell

3.2.15.1 *rotor, n*—a titanium rotor sized to give a compromise of sensitivity and range to the determination of viscosity and gelation using this test method.

3.2.15.2 *stator, n*—a precision-bore borosilicate glass tube, to which a measured amount of oil is added for the test and within which the specially-made rotor turns.

3.2.15.2.1 *stator collar, n*—a clamp for the stator which also positions it on the test cell alignment device.

3.2.15.3 *test cell alignment device, n*—a special device used to support the viscometer drive module while maintaining the stator and the rotor coaxial and vertical in regard to the viscometer driveshaft. Later designs admit dry gas into the cell to prevent moisture and frost buildup.

3.2.16 *test oil, n*—any oil for which apparent viscosity is to be determined using the procedure described by this test method.

3.2.17 *viscometer drive module, n*—the rotor drive and torque-sensing component of a rotational viscometer.

3.2.18 *viscometer module support, n*—a part of the test cell alignment device supporting the viscometer drive module.

4. Summary of Test Method

4.1 Used and sooted engine oils are analyzed using a special rotational viscometer with analog or digital output to a computer program. A specially made glass stator/metal rotor cell is attached to the viscometer and subjected to a programmed temperature change for both calibration and sample analysis. Following calibration of the rotor-stator set, an approximately 20 mL test sample of a test lubricating oil is poured into the stator and preheated for 1.5 h to 2.0 h at 90 °C in an oven or water bath. Shortly after completing the preheating step, the room-temperature rotor is put into the stator containing the heated oil and coupled to a torque-sensing viscometer head using an adapter to automatically center the rotor in the stator during test. A programmable low-temperature bath is used to cool the cell at a specified rate of 3 °C/h from –5 °C to the temperature at which the maximum torque recordable is exceeded when using a speed of 0.3 r/min for the rotor. After the desired information has been collected, the computer program generates the desired viscometric and rheological values from the recorded data.

5. Significance and Use

5.1 *Significance of Low Temperature, Low Shear Rate, Engine Oil Rheology*—The low-temperature, low-shear viscometric behavior of an engine oil, whether new, used, or sooted, determines whether the oil will flow to the sump inlet screen, then to the oil pump, then to the sites in the engine requiring lubrication in sufficient quantity to prevent engine damage immediately or ultimately after cold temperature starting. Two forms of flow problems have been identified,³ flow-limited and air-binding behavior. The first form of flow restriction, flow-limited behavior, is associated with the oil's viscosity; the second, air-binding behavior, is associated with gelation.

5.2 *Significance of the Test Method*—The temperature-scanning technique employed by this test method was designed to determine the susceptibility of the engine oil to flow-limited and air-binding response to slow cooling conditions by providing continuous information on the rheological condition of the oil over the temperature range of use.^{3,4,5} In this way, both viscometric and gelation response are obtained in one test.

NOTE 1—This test method is one of three related to pumpability related problems. Measurement of low-temperature viscosity by the two other pumpability test methods, D3829 and D4684, hold the sample in a quiescent state and generate the apparent viscosity of the sample at shear rates ranging up to 15 s⁻¹ and shear stresses up to 525 Pa at a previously selected temperature. Such difference in test parameters (shear rate, shear stress, sample motion, temperature scanning, and so forth) can lead to differences in the measured apparent viscosity among these methods with some test oils, particularly when other rheological factors associated with gelation are present. In addition, the three methods differ considerably in cooling rates.

5.3 *Gelation Index and Gelation Index Temperature*—This test method has been further developed to yield parameters called the Gelation Index and Gelation Index Temperature. The first parameter is a measure of the maximum rate of torque increase caused by the rheological response of the oil as the oil is cooled slowly. The second parameter is the temperature at which the Gelation Index occurs.

6. Apparatus

6.1 *Test Cell*—Shown in Fig. 1, consisting of a matched rotor and a stator of the following critical dimensions:

6.1.1 *Rotor Dimensions*—Critical length is 65.5 mm ± 0.1 mm and critical diameter is 18.40 mm ± 0.02 mm.

6.1.2 *Stator Dimensions*—Critical diameter is 22.05 mm (±0.02 mm) at whatever length will satisfy the immersion depth when the upper oil level is a minimum of 15 mm below the cooling liquid level over the entire temperature range.

6.2 *Viscometer Drive Modules*—Rotational viscometer drive modules capable of producing an analog signal to an analog-to-digital converter or other analog signal data processor such as a strip-chart recorder.

6.2.1 With the rotor and stator described in 6.1.1 and 6.1.2, the viscometer drive module must be capable of measuring to at least 90 000 mPa·s (cP).

⁵ Shaub, H., "A History of ASTM Accomplishments in Low Temperature Engine Oil Rheology," *Symposium on Low Temperature Lubricant Rheology Measurement and Relevance to Engine Operation, ASTM STP 1143*, Rhodes, R. B., ed., ASTM, 1992, pp. 1-19.

6.3 *Test Cell Alignment Device*—Simultaneously maintains a vertical axial alignment and reasonably consistent positioning of the rotor in the stator to give repeatable torque readout from test to test when setting up the apparatus for analysis.

6.3.1 *Viscometer Support*—Supports the viscometer drive module and aligns it vertically.

6.3.2 *Stator Collar*—Clamps the stator and supports it when the stator collar is attached to the viscometer support.

6.4 A means of providing a dry gas atmosphere over the top of the test sample is necessary to prevent condensation and freezing of water on the oil surface.

6.5 *Programmable Liquid Cooling Bath*—Liquid bath capable of running either the calibration or the testing program with temperature control of ± 0.1 °C over the temperature range desired at ± 3 °C/h.

6.5.1 *Temperature Controller* is set up to operate according to two programs, the calibration program and the test program. At any temperature the controller modulates temperature within 0.1 °C of the desired value.

6.6 *Computer, Analog-to-Digital Converter, and Analysis Program*—Means of receiving data from the viscometer drive module and converting this data into the desired information.

6.7 *Sample Pre-treatment Water or Air Bath*—A programmable water or air bath for both precise control of the test oils at 90 ± 2 °C and immersion time after the sample reaches pre-treatment temperature.

6.8 *Calibrated Liquid-in-Glass or Digital Contact Thermometer*, calibrated at 90 °C and reading to ± 0.2 °C.

7. Materials

7.1 *Calibration Oil*—A Newtonian calibration oil of known dynamic viscosity over a temperature range of -5 °C to -35 °C.

7.2 *Gelation Index Reference Oils, GIR-series, non-Newtonian Reference Oils*, having gelation indices of established values as well as related values for the gelation index temperatures.

7.3 *Finger Cots*, latex, used to close the top of the oil-filled stators when they are in the pre-treatment heating baths, particularly if subject to water condensation inside the stator when heated in water baths.

7.4 *Viscometer Heads*, equipped with torque signal output and suitable sensitivity.

7.5 *Temperature-programmable, Low-temperature Bath*.

7.6 *Torque Signal Recorder*—Computer, analog-to-digital converter, and data analysis program.

7.7 *Constant-temperature Oven or Water Bath*, (programmable or non-programmable) for preheating samples.

7.8 *Operator Calibrated, Temperature Measuring Devices*, for 90 °C and -20 °C.

7.9 *Newtonian Calibration Oil*.

7.10 *Source of Dry Air or Nitrogen Gas* and means of gas introduction over top of stator.

8. Sampling

8.1 Approximately a 20 mL sample of test oil is necessary for the test. The sample must be thoroughly shaken so that the sample is homogeneous (see 12.1).

NOTE 2—The submitter of samples should refer to Practice D4057 to be aware of how to properly acquire representative samples of petroleum products.

9. Preparation of Apparatus

9.1 Pre-treatment heating of samples using either a water bath or an oven.

9.1.1 *Water Baths*—Using boiling distilled water and correcting for barometric pressure (if significant because of altitude of the laboratory), check the calibration of liquid-in-glass or digital contact thermometer used in the pre-treatment water bath by appropriate methods.

9.1.1.1 Check the constant temperature of the pre-treatment water bath after ensuring that it is filled with distilled water to a level 20 mm above the oil level in the immersed stators. The temperature should be constant at 90 ± 2 °C.

9.1.2 *Ovens*—Check the calibration of the temperature sensing device by appropriate methods. The temperature should be constant at 90 ± 2 °C.

9.1.2.1 Determine the length of time required to bring the sample up to 90 °C. Use this time interval to establish the length of time the sample is held in the oven before being poured into the stator.

9.2 *Preparing Liquid Cold-bath*—Check the liquid level in the programmable liquid cold bath. Fill bath to proper depth according to supplier's instructions at -5 °C.

NOTE 3—To ensure adequate cooling fluid height above the sample, it is advisable to fill the bath at -5 °C to the appropriate level indicated by the manufacturer and to always bring the bath back to this temperature when on stand-by. This keeps down the evaporation rate. In addition, for many refrigerating baths, operation at some temperature moderately below room temperature maintains best operational response. Coolant should not be added to the bath while at lower temperatures to avoid overflow at room temperature as well as disruption of the cooling cycle.

9.2.1 Install or check the cooling programs for the programmable liquid cold bath. The programs to be implemented are shown in [Table 1](#) and [Table 2](#).

9.3 Determine that the upper hook threaded (left hand thread) to the viscometer drive module's driveshaft is firmly finger-tightened. In the tightening process, gently and slightly lift the driveshaft.

NOTE 4—Do *not* pull down or push or pull laterally on the driveshaft as this may harm the internal jeweled bearing and perhaps bend the driveshaft as well.

10. Preparation for Calibration of Cells and Testing of Samples

10.1 Programmable, Liquid-coolant, Cold Bath:

10.1.1 Check water content of methanol bath coolant every one to six months, depending on average ambient humidity levels. Water content should be less than 6 %. If not, replace bath coolant with fresh (<0.5 % water content) methanol.

10.1.2 Fill bath to proper level with fresh (<0.5 % water content) methanol coolant. Methanol coolant level in the bath should be a minimum of 15 mm above oil level in stator at lowest temperatures of analysis (see [Fig. 1](#)).

NOTE 5—The low-level indicator light is illuminated on the bath when the coolant level falls below 35 mm above the oil level in the stator.

10.1.3 Using the liquid bath temperature controller and manufacturer's instructions, temporarily set bath temperature at $-20\text{ }^{\circ}\text{C}$ and allow to come to equilibrium for 1 h. Check bath temperature using an accurate and sensitive temperature indicator such as a short-range, partial-immersion thermometer or other thermometric device. If the temperature indicator shows that the bath temperature is more than $\pm 0.2\text{ }^{\circ}\text{C}$ from set point on the bath thermoregulator, follow the bath manufacturer's instructions to readjust the control setting on bath thermoregulator to align bath temperature with temperature indicator.

NOTE 6—Accuracy of the temperature indicator should be checked against a distilled water ice-bath to determine any necessary temperature correction.

10.1.4 Follow the bath manufacturer's directions for using the thermocontroller for calibration and test programmed settings.

10.1.5 Set the bath to hold at $-5\text{ }^{\circ}\text{C}$ until either a calibration or test program is started.

10.2 Clean and prepare test cell rotors, rotor hook connectors, and stators.

10.2.1 Clean and dry test cell rotors and stators of any residues of oil from previous tests using suitable techniques before reusing.

10.2.2 Attach left-hand threaded rotor hook to rotor shaft connector by firmly finger-tightening the hook to the rotor to seat the connection.

10.2.2.1 Check the rotor shafts and connected hooks for straightness as directed by the manufacturer.

10.2.3 Attach left-hand threaded viscometer hook to viscometer drive-shaft connector (see [Fig. 1](#)) carefully. Exercise particular care that the viscometer drive-shaft connector is lifted slightly during hook connection so that no damage occurs to the jeweled pivot bearing within the viscometer head.

10.2.3.1 Check straightness of the viscometer head hook shank by running viscometer at 12 r/min and observing any shank oscillation. If oscillation occurs, the hook must be replaced. If oscillation is in the viscometer drive and not in the hook, the viscometer head must be repaired or replaced.

10.3 Set up oven or hot-water heating bath for preheating the sample at a temperature at $90\text{ }^{\circ}\text{C} \pm 2\text{ }^{\circ}\text{C}$.

TABLE 1 Program for Liquid Cold Bath to Obtain Calibration Information

Step	Action	$^{\circ}\text{C}$	Time
1	Cool to $-5\text{ }^{\circ}\text{C}$ and hold	-5	^A
2	Set up data acquisition and initiate program	-5	^A
3	Gather data at $-5\text{ }^{\circ}\text{C}$	-5	30 m
4	Cool to $-10\text{ }^{\circ}\text{C}$ and hold	-10	30 m
5	Cool to $-15\text{ }^{\circ}\text{C}$ and hold	-15	30 m
6	Cool to $-20\text{ }^{\circ}\text{C}$ and hold	-20	30 m
7	Cool to $-25\text{ }^{\circ}\text{C}$ and hold	-25	30 m
8	Cool to $-30\text{ }^{\circ}\text{C}$ and hold	-30	30 m
9	Cool to $-33\text{ }^{\circ}\text{C}$ and hold	-33	30 m
10	Cool to $-35\text{ }^{\circ}\text{C}$ and hold	-35	30 m
11	Return to $-5\text{ }^{\circ}\text{C}$ and hold	-5	^A

^A Indeterminate, non-critical period.