



Designation: D7280 – 15

# Standard Test Method for Quinoline-Insoluble (QI) Content of Tar and Pitch by Stainless Steel Crucible Filtration<sup>1</sup>

This standard is issued under the fixed designation D7280; the number immediately following the designation indicates the year of original adoption or, in the case of revision, the year of last revision. A number in parentheses indicates the year of last reapproval. A superscript epsilon ( $\epsilon$ ) indicates an editorial change since the last revision or reapproval.

## 1. Scope\*

1.1 This test method covers the determination of the quinoline-insoluble matter (QI) in tar and pitch using a stainless steel filtering crucible and a filtration membrane.

1.2 This test method was evaluated in round robin testing using materials in the range of zero to twenty quinoline insoluble weight percent (wt%).

1.3 Since this test method is empirical, strict adherence to all details of the procedure is necessary.

1.4 The values stated in SI units are to be regarded as standard. No other units of measurement are included in this standard.

1.5 *This standard does not purport to address all of the safety concerns, if any, associated with its use. It is the responsibility of the user of this standard to establish appropriate safety and health practices and determine the applicability of regulatory limitations prior to use.*

## 2. Referenced Documents

2.1 *ASTM Standards:*<sup>2</sup>

[D71 Test Method for Relative Density of Solid Pitch and Asphalt \(Displacement Method\)](#)

[D95 Test Method for Water in Petroleum Products and Bituminous Materials by Distillation](#)

[D329 Specification for Acetone](#)

[D362 Specification for Industrial Grade Toluene \(Withdrawn 1989\)](#)<sup>3</sup>

[D850 Test Method for Distillation of Industrial Aromatic Hydrocarbons and Related Materials](#)

[D2318 Test Method for Quinoline-Insoluble \(QI\) Content of Tar and Pitch](#)

[D4296 Practice for Sampling Pitch](#)

[E1 Specification for ASTM Liquid-in-Glass Thermometers](#)

[E11 Specification for Woven Wire Test Sieve Cloth and Test Sieves](#)

[E691 Practice for Conducting an Interlaboratory Study to Determine the Precision of a Test Method](#)

## 3. Summary of Test Method

3.1 The sample is digested in hot quinoline and filtered. The insoluble material is washed, dried, and weighed.

## 4. Significance and Use

4.1 This test method is useful in evaluating and characterizing tar and pitch. It is also useful as one element in establishing the uniformity of shipments and sources of supply.

## 5. Apparatus

5.1 *Filtering Crucibles*, stainless steel, with fine-screen bottom, 25 mL to 40 mL capacity, high-form.<sup>4</sup> See Fig. 1.

5.2 *Filter Membrane*, PFTE membrane without backing, 10  $\mu$ m porosity, 25 mm disk.<sup>5</sup>

5.3 *Filter Apparatus*, 500 mL filter flask and tube with crucible adapter.

5.4 *Sieves*, U.S. Standard 600  $\mu$ m (No. 30) and 250  $\mu$ m (No. 60), conforming to Specification E11.

5.5 *Electric Hot Plate or Water Bath*, maintained at 75 °C  $\pm$  5 °C.

<sup>1</sup> This test method is under the jurisdiction of ASTM Committee D02 on Petroleum Products, Liquid Fuels, and Lubricants and is the direct responsibility of Subcommittee D02.05 on Properties of Fuels, Petroleum Coke and Carbon Material.

Current edition approved Dec. 1, 2015. Published December 2015. Originally approved in 2006. Last previous edition approved in 2011 as D7280 – 06 (2011). DOI: 10.1520/D7280-15.

<sup>2</sup> For referenced ASTM standards, visit the ASTM website, www.astm.org, or contact ASTM Customer Service at service@astm.org. For *Annual Book of ASTM Standards* volume information, refer to the standard's Document Summary page on the ASTM website.

<sup>3</sup> The last approved version of this historical standard is referenced on www.astm.org.

<sup>4</sup> The sole source of supply of the crucibles known to the committee at this time is Drabik Tool & Die, 15601 Commerce Park Dr., Cleveland, OH 44142. If you are aware of alternative suppliers, please provide this information to ASTM International Headquarters. Your comments will receive careful consideration at a meeting of the responsible technical committee,<sup>1</sup> which you may attend.

<sup>5</sup> The sole source of supply of the filter membranes known to the committee at this time is Mitex brand, Part No. LCWP 02500, available from Millipore Corporation, 290 Concord Road Billerica, MA 01821. If you are aware of alternative suppliers, please provide this information to ASTM International Headquarters. Your comments will receive careful consideration at a meeting of the responsible technical committee,<sup>1</sup> which you may attend.

\*A Summary of Changes section appears at the end of this standard

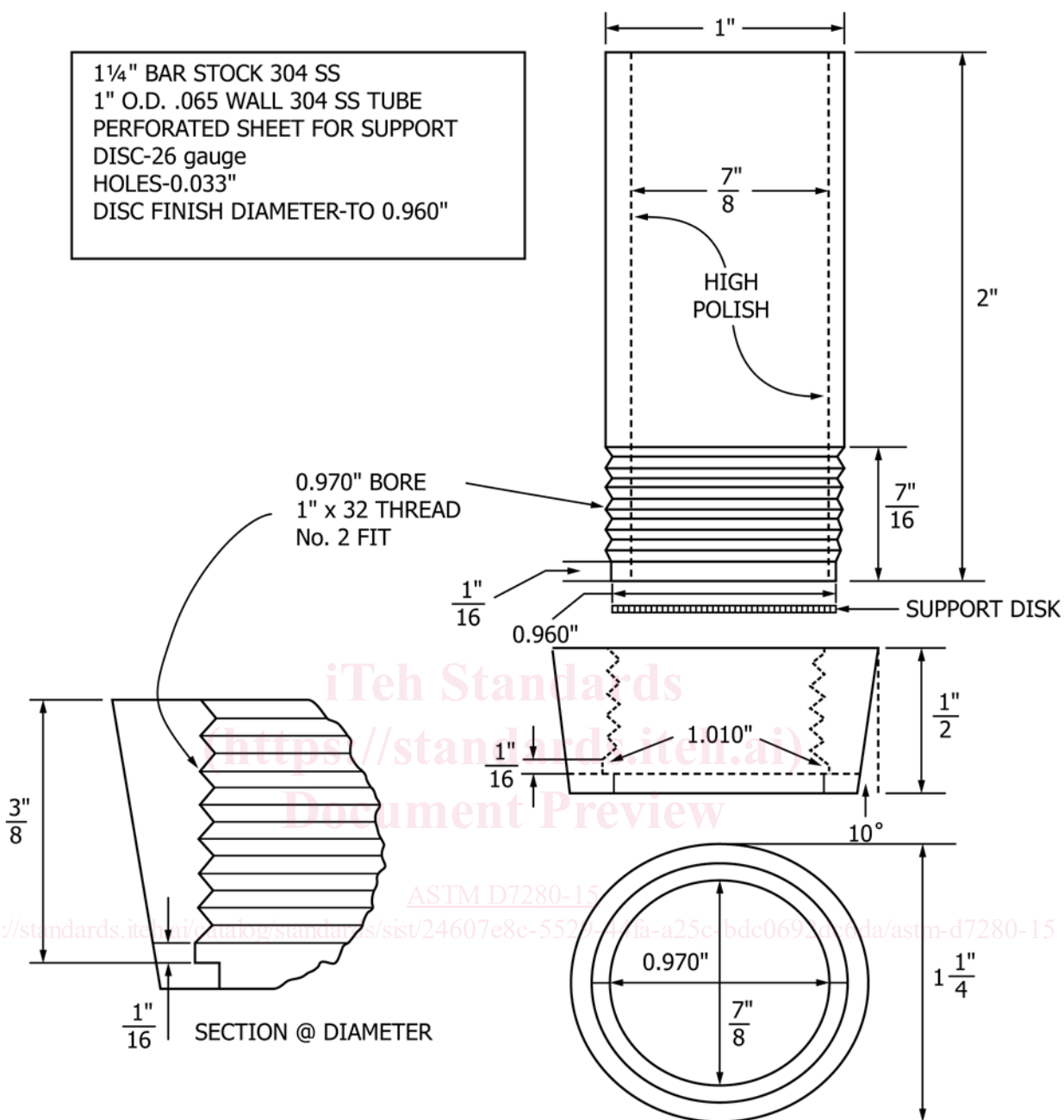

FIG. 1 Stainless Steel Filtering Crucible with Support Disk

## 6. Reagents and Materials

6.1 *Quinoline, Refined*—meeting the following requirements:

6.1.1 The quinoline shall distill from 5 % to 95 % within a range of 2 °C that shall include the temperature of 237.4 °C after corrections for barometric pressure and emergent stem have been applied. The distillation shall be carried out in accordance with Test Method D850 using a total immersion thermometer with a range from 195 °C to 305 °C, graduated in 0.5 °C, and conforming to the requirements for Thermometer 69C as described in Specification E1. Temperature measuring devices such as precision thermocouples, resistance tempera-

ture detectors (RTDs), and liquid-in-glass thermometers with equal or better accuracies in the appropriate temperature ranges can be used.

6.1.2 The quinoline shall have a specific gravity at 15.5/15.5 °C of 1.092 to 1.098, as determined by Test Method D71, or another method of equivalent accuracy.

6.1.3 The quinoline shall be clear and light in color and shall contain less than 0.5 volume % of water, as determined by Test Method D95. If not, redistill the quinoline in all-glass apparatus, discarding the first 5 % and collecting the next 90 %. If the quinoline contains suspended matter but is clear,