International Standard



3783

INTERNATIONAL ORGANIZATION FOR STANDARDIZATION • МЕЖДУНАРОДНАЯ ОРГАНИЗАЦИЯ ПО СТАНДАРТИЗАЦИИ • ORGANISATION INTERNATIONALE DE NORMALISATION

Paper and board — Determination of resistance to picking — Accelerating speed method using the IGT tester (Electric model)

Papier et carton — Détermination de la résistance à l'arrachage — Méthode d'impression à vitesse accélérée avec l'appareil IGT (modèle électrique)

iTeh STANDARD PREVIEW

First edition — 1980-02-15

(standards.iteh.ai)

[ISO 3783:1980](#)

<https://standards.iteh.ai/catalog/standards/sist/5bc555bd-d62e-425e-b1bd-939f9af85c01/iso-3783-1980>

UDC 676.017.435.2

Ref. No. ISO 3783-1980 (E)

Descriptors : papers, paperboards, tests, pull out tests, tear strength, printing equipment.

Price based on 7 pages

Foreword

ISO (the International Organization for Standardization) is a worldwide federation of national standards institutes (ISO member bodies). The work of developing International Standards is carried out through ISO technical committees. Every member body interested in a subject for which a technical committee has been set up has the right to be represented on that committee. International organizations, governmental and non-governmental, in liaison with ISO, also take part in the work.

Draft International Standards adopted by the technical committees are circulated to the member bodies for approval before their acceptance as International Standards by the ISO Council.

International Standard ISO 3783 was developed by Technical Committee ISO/TC 6, *Paper, board and pulps*, and was circulated to the member bodies in October 1978.

(standards.iteh.ai)

It has been approved by the member bodies of the following countries :

Belgium	India	Poland
Brazil	Iran	Romania
Canada	Ireland	South Africa, Rep. of
Chile	Israel	Spain
Czechoslovakia	Italy	Sweden
Egypt, Arab Rep. of	Kenya	Switzerland
Finland	Mexico	Turkey
Germany, F. R.	Netherlands	United Kingdom
Hungary	Norway	USSR

The member bodies of the following countries expressed disapproval of the document on technical grounds :

Austria
France
USA

Paper and board — Determination of resistance to picking — Accelerating speed method using the IGT tester (Electric model)

0 Introduction

A number of methods for assessing the picking resistance of paper, i.e. the ability of paper to withstand the forces involved in splitting of ink films in printing processes, have been developed and accepted in different countries. However, it has not been possible to achieve reproducibility between the results obtained by the different methods; nevertheless several of the methods do rank particular papers in the same order and to this extent enable comparisons to be made.

It is hoped that it will eventually be possible to achieve genuine reproducibility, but meanwhile it is considered necessary to provide internationally agreed guidance on the use of instruments that are employed in many countries. One of the most widely used pick testers is the IGT¹⁾ instrument. This International Standard deals with the electric model of that tester. ISO 3782 deals with other IGT instruments (pendulum or spring model), and the preparation of further methods is being considered.

1 Scope

This International Standard specifies a method of operating the electric model of the IGT printability tester in order to provide a measure of the picking resistance of paper and board.

2 Field of application

This International Standard applies to the testing of any kind of paper and board likely to be used for printing, mainly by lithographic or letterpress processes.

3 References

ISO 186, *Paper and board — Sampling for testing.*

ISO 187, *Paper and board — Conditioning of samples.*

4 Definitions

4.1 picking : The rupture of the surface of a paper or board during printing, which occurs when an external tensile force applied to the surface is greater than the cohesion of the paper or board.

NOTE — In the case of coated papers, the rupture may take the form of particles of coating or fibres wholly or partly detached from the sheet, "blistering" of the surface or gross stripping of the surface. In the case of board, "blistering" is called delamination and this is often reported separately from picking. In the case of uncoated papers the rupture normally takes the form of the removal of fibre aggregates.

4.2 picking velocity : The velocity of printing at which the picking of the surface of the printed paper begins.

5 Principle

A strip of paper or board is printed at constant force and increasing velocity with a standard oil.

The minimum velocity at which picking occurs is a measure of the picking resistance of the paper or board.

6 Apparatus and materials

6.1 IGT tester

The tester comprises two separate units : an oil applicator which enables an oil film of known (controlled) thickness to be placed on a printing disc, and a printing unit on which the drive is electric. Printing force is controlled by variable spring loading.

Slightly different versions of the electric model of the IGT tester are in existence, the differences being of detail and affecting mainly the positions of certain controls.

The description of the IGT tester given in 6.1, together with the detailed instructions given in clauses 10 and 11, apply to a version of the electric model in common use and a diagram of the printing unit is given in annex A.²⁾

1) Stichting Instituut voor Grafische Techniek TNO, Postbus 4150, 1009 AD Amsterdam.

2) See also Bibliography.

Annex B gives the amendments required to the text of 6.1.1 and 11.4 when using the version of IGT tester (electric model) available from the manufacturer during 1977¹⁾. A diagram of the electric model printing unit, in this version, is included in annex B.

NOTE — If there is any doubt concerning which version of IGT tester is being used, the instrument manufacturer should be consulted.

6.1.1 Printing apparatus

The printing apparatus consists of a semi-circular sector (8), having a radius of 85 mm, which is covered with standard packing against which the test piece is secured. The part of the sector used for the pick test is approximately 150°. This sector rotates with an increasing velocity against a smooth metal printing disc. The disc, which is 65 mm in diameter and 10 mm wide, presses against the test piece with a force that is adjustable to 345 ± 10 N (35 kgf)²⁾.

NOTE — Special attention is drawn to the importance of ensuring correct adjustment of the distance between the sector and the shaft (12) that carries the printing disc during printing, preferably in consultation with the instrument manufacturer.

The increasing velocity setting (14) that is required for the test is selected on the instrument only when the sector is in the starting position. The selector switch (3) is initially turned to the low velocity position. Maximum velocities up to 4 m/s may be selected by adjustment of the velocity control knob (5).

For each point on the test strip, the corresponding velocity should be known.

NOTE — Diagrams are supplied with the apparatus showing velocity versus distance on the strip (see 12.3 and 12.4).

The printing force is adjusted (9). The test piece is placed on the packing and secured. The printing disc on shaft (12) is in contact with the strip.

NOTE — Special attention is drawn to the importance of ensuring accurate calibration of the apparatus, preferably in consultation with the instrument manufacturer.

6.1.2 Oil application system

The distribution roller used for oil application shall be of polyurethane. The printing disc shall be provided with an even layer of oil $7,6 \pm 0,6$ μ m in thickness. This will normally be produced by the application of 1 ml of oil to the distribution system.

NOTE — The oil film thickness on the printing disc is checked by weighing the printing disc before and after inking, using a knowledge of the density of the oil.

6.2 Standard picking oils

6.3 Standard card packing material

The packing shall be $1,5 \pm 0,1$ mm thick.

NOTE — The Nederlands Normalisatie-Instituut (NNI), Postbus 5810, 2280 HV, Rijswijk (ZH) Netherlands, is willing to provide information as to the source of supply of appropriate oils and cards.

6.4 Oil-measuring devices

A balance capable of weighing a mass of approximately 60 g to an accuracy of $\pm 0,1$ mg.

A graduated ink pipette to dispense a volume to an accuracy of $\pm 0,01$ ml.

7 Sampling

Sample in accordance with ISO 186.

8 Conditioning

Condition the sample in accordance with ISO 187.

9 Preparation of test pieces

Cut 10 test pieces each for each side of the test material (for example, top side and wire side respectively) and also in the machine and cross directions, or as appropriate. Each test piece shall measure 350 mm \times 35 mm.

Mark the sides, and the machine and cross direction, on the test pieces. This marking shall be carried out in such a manner that it is possible, after the test pieces have been cut, both to identify each side of the test material and the machine direction and cross direction, and to test half the machine direction test pieces in one direction and half in the other.

10 Preparing the tester

10.1 Mounting and tensioning of packing

Turn the two small milled screws on the sector counter-clockwise as far as possible.

Press open the packing clamp (18) on the left-hand side of the sector and insert the glued edge of the packing as far as possible. Ensure that the packing is positioned exactly straight on the sector and clamp the glued end by means of the large milled nut.

1) See also Bibliography.

2) In view of the ISO decision to use SI units and their preferred multiples and sub-multiples, these have been adopted in this International Standard; metric technical units are given in parentheses as many existing instruments use these units for their scale readings.

Press open the packing clamp (7) on the right-hand side of the sector and insert the other end of the packing as far as possible between the two jaws. Clamp by tightening the large milled nut.

Stretch packing by turning clockwise, alternately, the small milled screws of the sector.

Renew the packing if it becomes damaged or shows obvious signs of wear.

10.2 Adjustment of printing force

Verify that the distance between the sector and the shaft (12) that carries the printing disc during printing has been correctly adjusted.

Mount the test piece on the sector so that it lies flat against the packing.

Turn the top printing-disc lifter (11) clockwise as far as it will go. Place an unoled printing disc on the shaft.

Turn the sector to its starting position.

Turn the top printing disc lifter (11) counter-clockwise as far as it will go.

Turn the tension adjuster (9) at the top of the right-hand side of the tester until the top printing force scale (13) reads 345 ± 10 N (35 kgf).

<https://standards.iteh.ai/catalog/standards/sist/5bc555bd-d62e-425e-b1bd-939f9af85c01/iso-3783-1980>

11 Procedure

11.1 Test conditions

Carry out all tests in the atmospheric condition at which the paper or board has been conditioned. Ensure that the tester and the test material are at the test temperature.

11.2 Inserting test pieces

Press open the paper clamp (18) on the left-hand side of the sector and insert the test piece between the jaws. Guide the test piece over the sector, keeping it in line with the sector. Press open the right-hand clamp and insert the folded end of the test piece under the clamp. It is unnecessary to stretch the strip over the sector.

11.3 Preparation of printing disc

Apply the appropriate quantity of oil to the oil application system and distribute it on the system for a minimum time of 8 min. Then place the printing disc on the appropriate shaft to receive the oil for a minimum time of 90 s.

NOTE — The use of the back rollers supplied with the IGT tester is optional.

11.4 Making a test

Set the selector pin (14) to the increasing velocity setting.

Set the selector switch (3) to the low velocity position.

Turn the top printing-disc lifter (11) clockwise as far as possible and place the oiled printing disc on the shaft (12) until it snaps into position.

Turn the sector with the test piece into the starting position, when the lamp (15) on the front of the apparatus should light.

Turn the top printing-disc lifter counter-clockwise as far as possible.

Turn the brush (16) to make contact with the test piece on the sector.

First depress the motor starting button (6) on the front of the apparatus, with the right hand. While keeping this button depressed, sharply press the sector starting button (1) on the left side of the apparatus with the left hand.

The sector will then rotate, making a print. Keep both buttons pressed during the printing.

When the sector has come to rest, remove the test piece from the clamps.

NOTE — Where necessary, the parties concerned should agree on the maximum velocity to be used, for example 1, 2, 3 or 4 m/s.

12 Determination of picking

12.1 Define the beginning of the print by marking the centre of the initial (stationary) contact area, which shows as a band across the print, bounded by darker lines about 5 mm apart.

12.2 The start of picking is the first visible sign of disturbance of the flat printed surface when viewed at a suitable magnification (for example X 5) with oblique illumination in the printing direction. Isolated picked spots separated by more than 20 mm from the main area of picking should not be regarded as the start of picking. If such spots occur in a number of sheets, this should be reported.

While ordinary picking is best seen from a straight strip, the delamination of board (see the note to 4.1) should be observed without magnification on a strip which is bent with the printed side inwards. Since repeated bending causes delamination, the strip should be bent only once and this is conveniently done in a special jig with a curvature of 55 mm.

NOTE — The appearance of debris on the printing disc should be observed, since very minute picking may be missed on the strip. It is best to carry out the observation of the test prints as soon as possible.

12.3 Lay the printed strip along the horizontal axis of a diagram of velocity against sector displacement or use a velocity-distance scale. Ensure that the beginning of the print coincides with the zero of the scale.

12.4 Read off, on the vertical axis of the diagram, or from the scale, the picking velocity.

NOTE — Precise values cannot normally be expected when picking starts within 20 mm of the beginning. In that event, use a lower maximum velocity.

12.5 Note the type of picking that has occurred.

13 Steps for subsequent tests

Clean the printing disc with a cloth soaked in low boiling point solvent, such as petroleum ether, boiling point range 60 to 100 °C. Wipe dry with a clean cloth.

NOTE — The printing disc shall be allowed to return to the temperature of the conditioning atmosphere before making the next test.

Repeat the test procedure according to clauses 11 and 12 for the next test.

After 10 tests have been carried out, it is preferable to clean and recharge the oil application system. Ensure that all traces of solvent have been removed before applying the fresh oil.

In those instances in which more than 10 tests are made in rapid succession, maintain the correct film thickness by adding the appropriate volume (that is, approximately 0,16 ml per 10 tests) of fresh oil to the oil application system.

14 Test report

The test report shall refer to this International Standard, and include the following :

- a) oil used;
- b) maximum velocity used;
- c) mean picking velocity in millimetres per second, rounded to the nearest 50 mm/s, the values for each side and direction (that is, machine or cross direction) of the test material being reported separately;
- d) standard deviation;
- e) atmospheric conditions of test;
- f) description of picking observed, including isolated spots on a number of test pieces;
- g) any deviation from this procedure, for example the use of fewer test pieces, and any circumstances of such a nature as to influence the results (see, for example, the note to 12.4).

In the case of board the test report may also include :

- h) mean delamination velocity (see the note to 4.1) expressed in metres per second, rounded to the nearest 0,5 m/s;
- i) standard deviation of delamination velocity.

15 Bibliography

- [1] STICHTING INSTITUUT VOOR GRAFISCHE TECHNIEK TNO, Amsterdam. *Manual of instructions for the application of the type AC1 IGT printability tester*. Operating Instruction No. 16 (2nd revised edition, April 1966).
- [2] BLOKHUIS, G. *Applications of the IGT-printability tester*, IGT Publication No. 12 (4th revised edition, July 1963).
- [3] BLOKHUIS, G. *Picking resistance of paper*, IGT-Nieuws, Vol. 20, No. 1, Jan/Feb 1967, pp. 6-9.
- [4] GLASSMANN, A. *The proposed Tappi suggested method for pick testing on accelerating speed print makers*, Tappi, Vol. 46, No. 7, July 1963, pp. 137A-141A.
- [5] STICHTING INSTITUUT VOOR GRAFISCHE TECHNIEK TNO, Amsterdam. *Instruction manual for model AIC2 or AC2*, 1977.
- [6] JANSEN, F. B. *Applications of the IGT-printability testers*, IGT Monograph No. 12, April 1972.

Annex A

Diagram of IGT printability tester (electric model) in common use

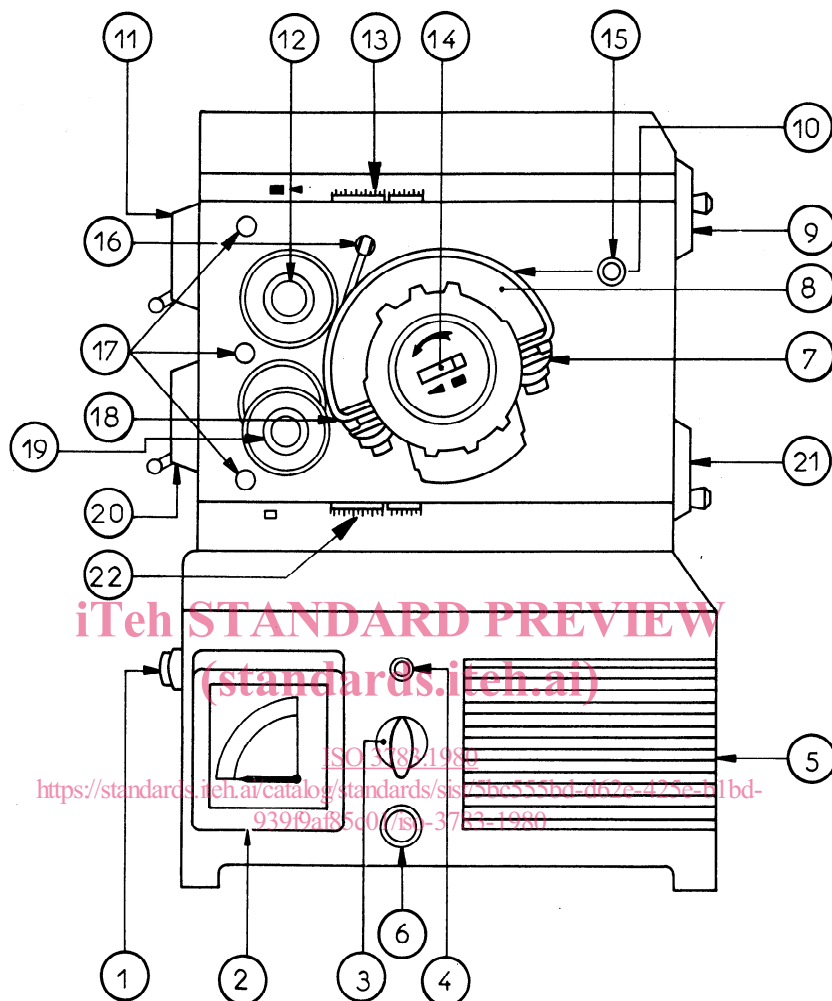

KEY

- | | |
|--|---|
| <p>1 Sector starting button. Pressing has an effect only when 6 is depressed and 15 is alight</p> <p>2 Velocity indicator</p> <p>3 Main switch and selector switch for velocity. This switch has three positions, namely :</p> <p style="margin-left: 20px;">L – constant velocity up to 1,7 m/s and increasing velocity up to 4 m/s</p> <p style="margin-left: 20px;">H – constant velocity up to 5 m/s</p> <p style="margin-left: 20px;">O – in this position the tester is switched off.</p> <p>4 Pilot lamp. Lights only when switch 3 is in position L or H</p> <p>5 Velocity control with locking button</p> <p>6 Motor starting button. When pilot lamp 4 is alight the motor is switched on by pressing this button</p> <p>7 and 18 Packing and paper clamp; the packing is held in the clamps, and the paper can be clamped separately</p> <p>8 Sector or impression cylinder</p> | <p>9 Printing force control for top printing-disc</p> <p>10 Packing</p> <p>11 Top printing-disc lifter; with this the printing-disc can be lifted off the sector, and in addition the distance between the top printing-disc shaft and the sector can be varied</p> <p>12 Top printing-disc shaft</p> <p>13 Printing force scale for top printing-disc</p> <p>14 Selector pin for type of velocity</p> <p>15 Pilot lamp. Lights only when the sector is in its starting position</p> <p>16 Brush (detachable)</p> <p>17 Holes for attachment of accessories</p> <p>18 See 7</p> <p>19, 20 } As 12, 11, 9, 13, but for the lower printing disc. These are
 21, 22 } not used for picking tests</p> |
|--|---|

Annex B

1977 Version of IGT tester (electric model)

When the 1977 version of the IGT tester (electric model) is used, sub-clauses 6.1.1 and 11.4 of this International Standard should be amended as indicated below. A diagram of the 1977 electric model printing unit is included in this annex.

The amendments referred to are :

- 1) In sub-clause 6.1.1, second paragraph, delete the term "selector switch (3)" and replace with "selector switch (23)".
- 2) At the end of sub-clause 6.1.1, second paragraph, add the following text :
The maximum velocity may be increased to 7 m/s by setting switch (23) to the high speed position.
- 3) In sub-clause 11.4, seventh paragraph, first sentence, delete the word "front" and replace with "right side".
- 4) In the note at the end of sub-clause 11.4, delete the phrase "1, 2, 3 or 4 m/s" and replace with "1, 2, 3, 4, 5, 6 or 7 m/s".

iTeh STANDARD PREVIEW
(standards.iteh.ai)

[ISO 3783:1980](https://standards.iteh.ai/catalog/standards/sist/5bc555bd-d62e-425e-b1bd-939f9af85c01/iso-3783-1980)

<https://standards.iteh.ai/catalog/standards/sist/5bc555bd-d62e-425e-b1bd-939f9af85c01/iso-3783-1980>

Diagram of IGT printability tester (electric model) — 1977 Version

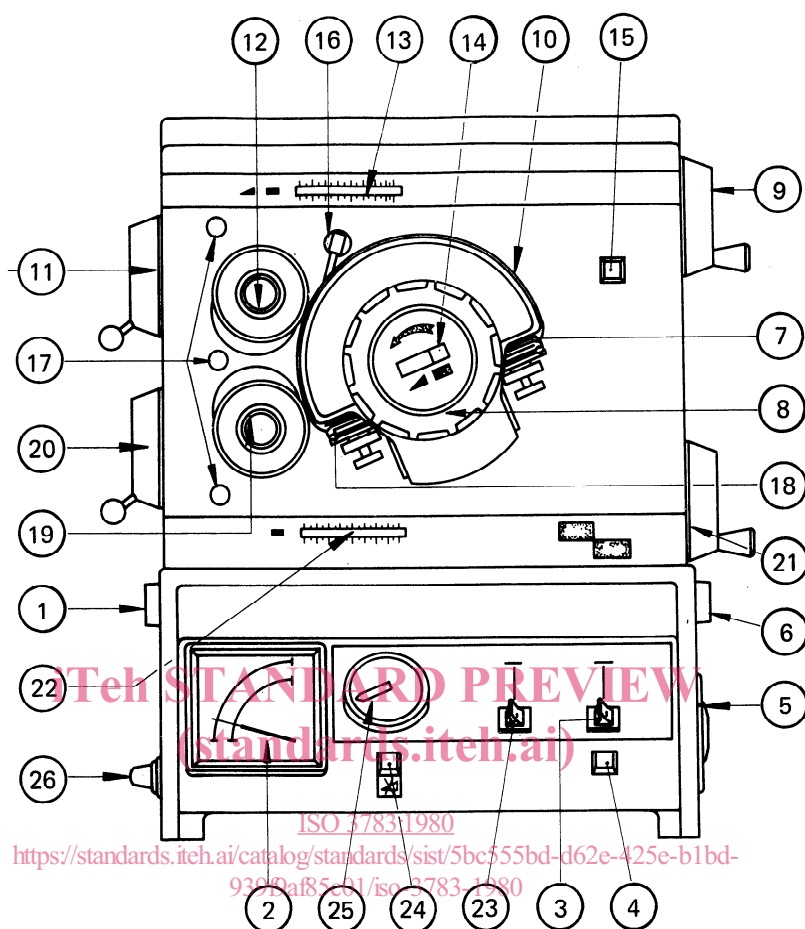

KEY

- | | |
|--|---|
| <p>1 Sector starting button. Pressing has an effect only when 6 is depressed and 15 is alight</p> <p>2 Velocity indicator</p> <p>3 Main switch</p> <p>4 Pilot lamp. Lights only when switch 3 is in the "on" position</p> <p>5 Velocity control with locking button</p> <p>6 Motor starting button. When pilot lamp 4 is alight the motor is switched on by pressing this button</p> <p>7 and 18 Packing and paper clamp; the packing is held in the clamps, and the paper can be clamped separately</p> <p>8 Sector or impression cylinder</p> <p>9 Printing force control for top printing-disc</p> <p>10 Packing</p> <p>11 Top printing-disc lifter; with this the printing-disc can be lifted off the sector, and in addition the distance between the top printing-disc shaft and the sector can be varied.</p> <p>12 Top printing-disc shaft</p> | <p>13 Printing force scale for top printing-disc</p> <p>14 Selector pin for type of velocity</p> <p>15 Pilot lamp. Lights only when the sector is in its starting position</p> <p>16 Brush (detachable)</p> <p>17 Holes for attachment of accessories</p> <p>18 See 7</p> <p>19, 20 } As 12, 11, 9, 13, but for the lower printing disc. These are not used for picking tests</p> <p>21, 22 }</p> <p>23 Selector switch. For increasing velocity, the maximum velocity is 4 m/s in the "low" position and 7 m/s in the "high" position</p> <p>24 Pilot lamp, showing that the apparatus is in the intermittent printing position (not used for picking tests)</p> <p>25 Timer for intermittent printing (not used for picking tests)</p> <p>26 Fuse</p> |
|--|---|