



Designation: **F1055 – 13 F1055 – 15**

Standard Specification for Electrofusion Type Polyethylene Fittings for Outside Diameter Controlled Polyethylene and Crosslinked Polyethylene (PEX) Pipe and Tubing¹

This standard is issued under the fixed designation F1055; the number immediately following the designation indicates the year of original adoption or, in the case of revision, the year of last revision. A number in parentheses indicates the year of last reappraisal. A superscript epsilon (ϵ) indicates an editorial change since the last revision or reappraisal.

1. Scope*

1.1 This specification covers electrofusion polyethylene fittings for use with outside diameter-controlled polyethylene pipe, covered by Specifications [D2513](#), [D2737](#), [D3035](#), and [F714](#) and crosslinked polyethylene (PEX), covered by Specifications [F876](#) and [F2788](#). Requirements for materials, workmanship, and testing performance are included. All requirements for joining PE electrofusion fittings to PE pipe shall also apply to joining PE electrofusion fittings to PEX pipe. Where applicable in this specification “pipe” shall mean “pipe” or “tubing.”

1.2 The values stated in inch-pound units are to be regarded as standard. The values given in parentheses are mathematical conversions to SI units that are provided for information only and are not considered standard.

1.3 The following safety hazards caveat pertains only to the test method portion, Section 9, of this specification: *This standard does not purport to address all of the safety concerns, if any, associated with its use. It is the responsibility of the user of this standard to establish appropriate safety and health practices and determine the applicability of regulatory limitations prior to use.*

2. Referenced Documents

2.1 ASTM Standards:²

- [D638](#) Test Method for Tensile Properties of Plastics
- [D1598](#) Test Method for Time-to-Failure of Plastic Pipe Under Constant Internal Pressure
- [D1599](#) Test Method for Resistance to Short-Time Hydraulic Pressure of Plastic Pipe, Tubing, and Fittings
- [D1600](#) Terminology for Abbreviated Terms Relating to Plastics
- [D2513](#) Specification for Polyethylene (PE) Gas Pressure Pipe, Tubing, and Fittings
- [D2737](#) Specification for Polyethylene (PE) Plastic Tubing
- [D3035](#) Specification for Polyethylene (PE) Plastic Pipe (DR-PR) Based on Controlled Outside Diameter
- [D3350](#) Specification for Polyethylene Plastics Pipe and Fittings Materials
- [F412](#) Terminology Relating to Plastic Piping Systems
- [F714](#) Specification for Polyethylene (PE) Plastic Pipe (DR-PR) Based on Outside Diameter
- [F876](#) Specification for Crosslinked Polyethylene (PEX) Tubing
- [F905](#) Practice for Qualification of Polyethylene Saddle-Fused Joints
- [F1473](#) Test Method for Notch Tensile Test to Measure the Resistance to Slow Crack Growth of Polyethylene Pipes and Resins
- [F2788](#) Specification for Metric and Inch-sized Crosslinked Polyethylene (PEX) Pipe

2.2 PPI Standards:³

- [PPI TR-3](#) Policies and Procedures for Developing Hydrostatic Design Basis (HDB), Pressure Design Basis (PDB), Strength Design Basis (SDB), and Minimum Required Strength (MRS) Rating for Thermoplastic Piping Materials or Pipe
- [PPI TR-4](#) HDB/SDB/PDB/MRS Listed Materials, PPI Listing of Hydrostatic Design Basis (HDB), Strength Design Basis (SDB), and Minimum Required Strength (MRS) Rating for Thermoplastic Piping Materials or Pipe

¹ This specification is under the jurisdiction of ASTM Committee F17 on Plastic Piping Systems and is the direct responsibility of Subcommittee F17.10 on Fittings. Current edition approved Feb. 1, 2013. Published February 2013. Originally approved in 1987. Last previous edition approved in 2012 as [F1055 – 12](#); [F1055 – 13](#). DOI: 10.1520/F1055-13.10.1520/F1055-15.

² For referenced ASTM standards, visit the ASTM website, www.astm.org, or contact ASTM Customer Service at service@astm.org. For *Annual Book of ASTM Standards* volume information, refer to the standard's Document Summary page on the ASTM website.

³ Available from Plastics Pipe Institute (PPI), 105 Decker Court, Suite 825, Irving, TX 75062, <http://www.plasticpipe.org>.

*A Summary of Changes section appears at the end of this standard

TABLE 1 Specification D3350 Classification Requirements of Polyethylene Electrofusion Fitting Materials

Physical Properties	Cell Classification and Properties for Polyethylene Materials	
	PE2708	PE4710
Density	2	4
Melt Index	3 or 4	4
Flexural Modulus	≥4	≥5
Tensile Strength	≥3	≥4
Slow Crack Growth Resistance (F1473)	7	7
Hydrostatic Strength Classification	3	4
Color and UV Stabilizer	C or E	C or E
HDB at 73°F (23°C), psi (MPa)	1250 (8.62)	1600 (11.03)

3. Terminology

3.1 *Definitions*—Definitions are in accordance with Terminology F412, and abbreviations are in accordance with Terminology D1600, unless otherwise specified.

3.2 *Definitions of Terms Specific to This Standard:*

3.2.1 *electrofusion*—a heat fusion joining process where the heat source is an integral part of the fitting, such that when electric current is applied, heat is produced that melts and joins the plastics.

3.2.2 *fusion interface*—surface in the heat fusion process where the plastic materials of the products being joined bond together.

3.2.3 *fusion zone length*—total length of the melted material in the fitting cross-section under evaluation.

4. Materials and Manufacture

4.1 This specification covers fittings made from polyethylene compounds as defined in Specification D3350.

4.1.1 Polyethylene material compounds suitable for use in the manufacture of electrofusion fittings under this specification shall meet Specification D3350 and shall meet Specification D3350 classification and property requirements shown in Table 1 and shall have PPI TR-4 HDB and HDS listings at 73°F (23°C) and HDB listings at 140°F (60°C).

4.2 *Rework Material*—Clean rework polyethylene material of the same resin, free of any wire or contaminants generated from the fitting manufacturer's own production, may be used by the same manufacturer, as long as the fittings produced conform to the requirements of this specification.

4.3 *Heating Mechanism*—The heat mechanism shall be of materials and design not detrimental to the performance of the fitting or the pipe to which it is intended to be joined. Heating mechanisms, such as wires or materials other than polyethylene, shall not exit the fitting in an area exposed to internal pressure. Heat mechanisms shall be of a design that ensures that wire terminations are toward the outer edges of the fusion zone length and away from the pressure containing area. Examples of acceptable and unacceptable wire terminations are shown in Figs. 1-5.

4.4 *Removal of exterior layers*—For PEX pipes containing an exterior non-PEX layer, such layers shall be completely removed according to the manufacturer's instructions prior to making the electrofusion joint. The dimensions of the PEX pipe after removal of non-PEX exterior layer/s shall meet the requirements of the relevant tubing or pipe Specifications F876 or F2788.

4.5 PEX pipe utilizing a mid-wall non-PEX layer are outside the scope of this standard and therefore shall not be used to qualify fittings to this standard.

5. Performance Requirements

5.1 The following requirements are for electrofusion joints that have been joined using the manufacturer's recommended joining procedures. These requirements must be met by each electrofusion joint design, on each size and type of pipe material for which the manufacturer recommends use of his fitting. Any revisions to the electrofusion joint design or processing by the manufacturer after the initial testing requires retesting to ensure these requirements can still be met. Fittings intended for use in the distribution of natural gas or liquid petroleum gas shall also meet the requirements of Specification D2513.

5.1.1 Assemblies using PEX pipes joined with electrofusion fittings shall be limited to the HDS rating of the PE material of the fitting as per 4.1.1 with a maximum usage temperature of 140°F.

5.1.2 Assemblies using PEX pipes joined with electrofusion fittings shall not be used for distribution of natural gas or liquid petroleum gas.

5.1.3 It is not required that each configuration of a fitting be tested to meet all of these qualifications (that is, 2 in. main saddle joint with multiple outlet configurations offered) as long as the electrofusion joint design is not altered in the configuration differences.

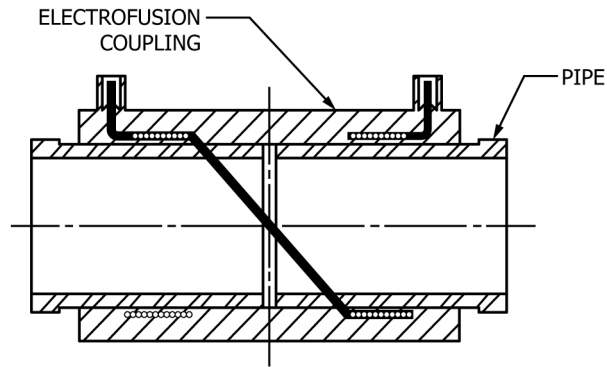

FIG. 1 Correct Wire Termination Coupling—Single Coil

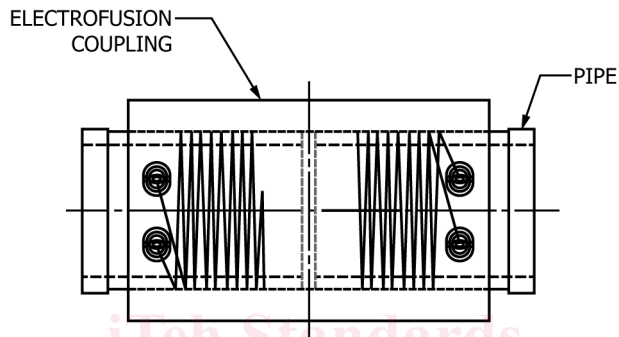

FIG. 2 Correct Wire Termination Coupling—Dual Coil

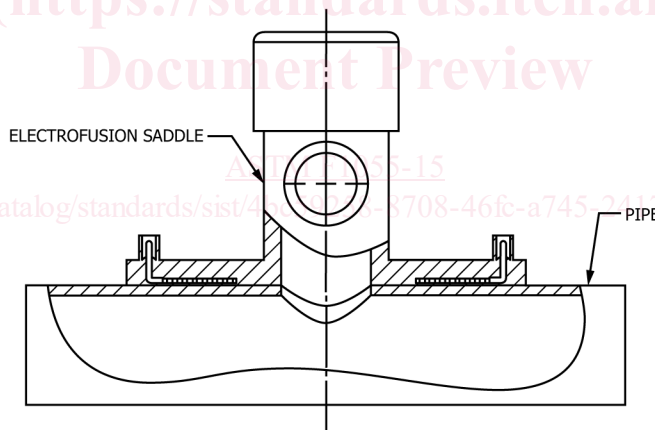

FIG. 3 Correct Wire Termination—Saddle Fitting

NOTE 1—It is permissible when accomplishing these tests, to do so on the highest and lowest dimension ratio of the same pipe material. If in those tests all performance requirements are met, all dimension ratios between those tested may be considered as having met the requirements. These tests do not have to cover the full range of dimension ratios available, only the dimension ratio range on which the manufacturer recommends his fitting be used.

5.2 Pressure Requirements:

5.2.1 Minimum Hydraulic Burst Pressure—The fitting and fused joint shall not fail when tested in accordance with 9.1. The minimum hydraulic burst pressure at 73°F (23°C) of the test specimen shall not be less than that required to produce the minimum fiber stress in the pipe as required by the controlling pipe standard for the type of pipe used in the test. In no case shall the minimum hydraulic burst pressure be less than that required to produce 2520 psi (17.4 MPa) fiber stress in the pipe for medium density PE (density cell 2) and 2900 psi (20 MPa) fiber stress in the pipe for high density PE (density cell 3 or 4) test specimens when tested in accordance with 9.1. The test equipment, procedures, and failures definitions shall be as specified in Test Method D1599.

5.2.2 Sustained Pressure—The fitting and fused joint shall not fail when tested in accordance with 9.2. The test pressure, minimum time-to-failure, and test temperature shall be as required by the controlling pipe standard for the type of pipe used in the test. Where the controlling pipe standard requires testing at multiple temperatures, sustained pressure testing shall only be

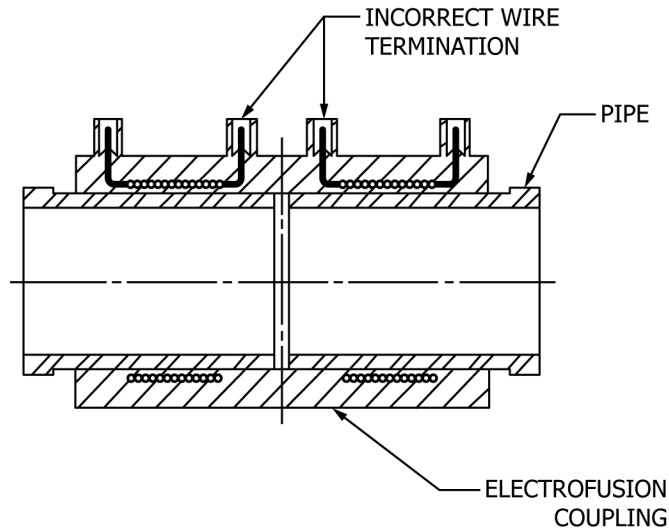

FIG. 4 Incorrect Wire Termination Coupling—Dual Coil

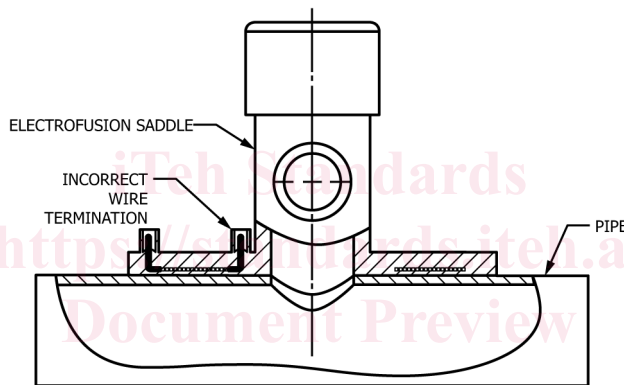

FIG. 5 Incorrect Wire Termination Saddle—Single Coil

<https://standards.iteh.ai/catalog/standards/sist/4bc59258-8708-46fe-a745-2417fbb4183/astm-f1055-15> performed at the highest test temperature, not to exceed 180°F (82°C). If a pipe standard is not specified, or does not contain test requirements, the test pressure, minimum time-to-failure and test temperature shall be as shown in **Table 2**.

5.3 *Tensile Strength Requirements (Coupling Type Joints Only)*—The fitting or the pipe to fitting joint made on pipe shall not fail when tested in accordance with 9.3. Specimens shall be subjected to a tensile stress that causes the pipe to yield to an elongation no less than 25 % or causes the pipe to break outside the joint area. Tensile tests must be made on specimens as joined, not on straps cut from the specimen. Yielding must be measured only in the pipe, independent of the fitting or joint.

5.4 *Impact Resistance (Saddle Type Joints Only)*—The joint made on the specimen shall not fail when impacted with a force sufficient to break the body or other portion of the specimen. Tests of 500 ft-lbf or higher impact with no failures noted shall be considered as a “pass” impact test. The device for testing and the methods shall be as defined in Practice F905.

5.5 *Joint Integrity Tests—(Couplings and Saddle Type Joints)*—The joint made on the specimen shall meet the requirements in 9.4 and 9.5 of this specification, when tested in accordance with 9.4.

6. Dimensions, Mass, and Permissible Variations

6.1 Dimension and tolerances of electrofusion fittings must be such that heat fusion is possible to outside diameter (OD) controlled PE pipes such as those listed in Specifications D2513, D2737, D3035, and F714 and PEX pipes listed in Specification Specifications F876 and F2788, such that the joints will satisfy the performance requirements in Section 5.

6.2 Because of the varying designs for electrofusion fittings, the actual spread of dimensions may be quite different from manufacturer to manufacturer. A table of dimensions and tolerances encompassing these differences would be meaningless and without value and, therefore, is omitted from this specification.

6.3 The manufacturer shall furnish to the user the electrical resistance, critical dimensions, and tolerances of his fittings. This information must include at least the following dimensions and tolerances:

6.3.1 Coupling inside diameter,

TABLE 2 Supplemental Sustained Pressure Test Requirements for the Pipe Material Being Tested

Condition	Test Temperature °C (°F) ^A	PE2408, PE2706, PE2708		PE3408, PE3608, PE3708, PE3710, PE4708, PE4710	
		Test Pressure Hoop Stress psi ^B (kPa) ^A	Minimum Average Time Before Failure Hours	Test Pressure Hoop Stress psi ^B (kPa) ^A	Minimum Average Time Before Failure Hours
Condition	Test Temperature °F (°C) ^A	Test Pressure Hoop Stress psi ^B (kPa) ^A	Minimum Average Time Before Failure Hours	Test Pressure Hoop Stress psi ^B (kPa) ^A	Minimum Average Time Before Failure Hours
1	80 (176)	670 (4620)	170	750 (5170)	200
1	176 (80)	670 (4620)	170	750 (5170)	200
2	80 (176)	650 (4480)	340	730 (5020)	400
2	176 (80)	650 (4480)	340	730 (5020)	400
3	80 (176)	630 (4345)	510	705 (4870)	600
3	176 (80)	630 (4345)	510	705 (4870)	600
4	80 (176)	610 (4210)	680	685 (4715)	800
4	176 (80)	610 (4210)	680	685 (4715)	800
5	80 (176)	590 (4070)	850	660 (4565)	1000
5	176 (80)	590 (4070)	850	660 (4565)	1000
6	80 (176)	580 (4000)	1000	640 (4415)	1200
6	176 (80)	580 (4000)	1000	640 (4415)	1200

^ATest temperature tolerance $\pm 2^\circ\text{C}$ ($\pm 3.6^\circ\text{F}$), -4°F ($\pm 2^\circ\text{C}$). Test pressure tolerance ± 5 psi (± 35 kPa); test pressure hoop stress values are rounded to the nearest 5 psi or 5 kPa.

Table 2 conditions are based on PE validation requirements per PPI TR-3 with Condition 6 being 85% of Condition 1 hoop stress and six times greater minimum average time before failure. Conditions 2 through 5 are linear stress and time interpolations between Condition 1 and 6. The intent of multiple conditions is to maintain equivalent performance criteria, but provide for retest in the event of a ductile failure. The test pressure hoop stress levels for Conditions 2-5 are linear interpolations for arbitrarily chosen time increments. An equivalent performance requirement, however, may be determined by arbitrarily choosing a test pressure hoop stress between Conditions 1 and 6 and linearly interpolating the minimum average time before failure. For example for PE4710 material, at 670 psi test pressure hoop stress, the minimum average time before failure would be 927 hours ($200 + (750 - 670) \cdot ((1200 - 200) / (750 - 640)) = 927$).

^BCalculate internal test pressure in accordance with:

$$P = \frac{2S}{\left(\frac{D_o}{t} - 1\right)}$$

where:

- P = test pressure, psig (kPa)
- S = test pressure hoop stress, psi (kPa)
- D_o = measured outside pipe diameter, in. (mm)
- t = measured minimum pipe wall thickness, in. (mm)

iTech Standards
(<https://standards.iteh.ai>)
Document Preview

ASTM F1055-15

<https://standards.iteh.ai/catalog/standards/sist/4bc59258-8708-46fc-a745-2417fbb4183/astm-f1055-15>

- 6.3.2 Temperature joining limits, and
- 6.3.3 Operating pressure of the fitting.

NOTE 2—There are other items that fall beyond the scope of this specification which would be of interest to the user for proper application of the fittings and is recommended as additional information to be furnished. A few of these are: (1) maximum pipe out of round allowed at joint area; (2) minimum/maximum pipe SDR capability of the fitting, and (3) for saddles intended for use on a live main, the maximum allowable line pressure when making the joint.

7. Workmanship, Finish, and Appearance

7.1 The manufacture of these fittings shall be in accordance with good commercial practice so as to produce fittings meeting the requirements of this specification.

7.2 The fittings shall be homogeneous throughout, except where a heating coil or electrical connectors are incorporated, and free of cracks, holes, foreign inclusions, or injurious defects such as gouges, dents, cuts, etc. The fittings shall be as uniform as commercially practicable in opacity, density, and other physical properties. Any heating coils, connecting cables, connectors, and related electrical power source shall be designed to prevent electrical shock to the user.

8. Specimen Preparation

8.1 Conditioning:

8.1.1 Unless otherwise specified, condition the specimens (pipe and fittings) prior to joining at the minimum pipe temperature allowable for fusion as recommended by the manufacturer, for not less than 16 h and make the fusion joint at that temperature for those tests where conditioning is required.

8.1.2 Unless otherwise specified, condition the specimens (pipe and fittings) prior to joining at the maximum pipe temperature allowable for fusion as recommended by the manufacturer, for not less than 16 h and make the fusion joint at that temperature for those tests where conditioning is required.

8.2 *Test Conditions*—Conduct the tests at the Standard Laboratory Temperature of $2373 \pm 2^\circ\text{C}$ ($73.43.6^\circ\text{F}$ ($23 \pm 3.6^\circ\text{F}$)) 2°C) unless otherwise specified.

8.3 *Preparation of Specimens for Testing:*

8.3.1 Prepare test specimens so that the minimum length of unreinforced pipe on one side of any fitting is equal to three times the diameter of the pipe, but in no case less than 12 in. (304 mm). It is permissible to test multiple fittings together provided they are separated by a minimum distance equal to three times the diameter of the pipe, but in no case less than 12 in. (304 mm).

8.3.2 Fuse all fitting outlets with the appropriate size pipe in accordance with the manufacturer's recommended procedures.

8.3.2.1 For PEX pipes containing an exterior non-PEX layer, such layers shall be completely removed according to the manufacturer's instructions prior to making the electrofusion joint.

(1) There shall be no damage to the base pipe after removal of the layer/s has taken place.

(2) The dimensions of the PEX pipe after removal of non-PEX exterior layer/s shall meet the requirements of the relevant tubing or pipe Specifications **F876** and **F2788**.

8.3.3 All saddle fusion joint specimens conditioned as in 8.1.2 and destined for quick burst testing as in 9.1 and sustained pressure testing as in 9.2, are to be joined with the pipe at no less than maximum allowable operating pressure of the pipe system or fitting, whichever is lowest, when being prepared for those tests. The pipe should be left under pressure for a time period not less than recommended by the manufacturer for cooling in the field prior to disturbing the joint. Saddle joint specimens destined for mechanical/destructive type tests such as impact as in 5.4 or crush tests as in 9.4, or specimens conditioned for cold temperature joining as in 8.1.1, may be made on unpressured pipe specimens.

9. Test Methods

9.1 *Minimum Hydraulic Burst Pressure Test:*

9.1.1 Select four fittings at random and prepare specimens in accordance with Section 8. From the four specimens, condition two specimens each in accordance with 8.1.1 and 8.1.2.

9.1.2 Test the specimens in accordance with Test Method **D1599**.

9.1.3 Failure of the fitting or joint shall constitute specimen failure.

9.1.4 Failure of any one of the four specimens shall constitute failure of the test. Failure of one of the four specimens tested is cause for retest of four additional specimens, joined at the failed specimens joining temperature. Failure of any of these four additional specimens constitutes a failure of the test.

9.2 *Sustained Pressure Test:*

9.2.1 Select four fittings at random and prepare specimens in accordance with Section 8 of this specification. From the four specimens, condition two specimens each in accordance with 8.1.1 and 8.1.2.

9.2.2 Test the specimens in accordance with Test Method **D1598**. ~~All tests shall be conducted at $80 \pm 2^\circ\text{C}$.~~ The assemblies are to be subjected to pipe fiber stresses and minimum test periods in accordance with the controlling pipe standards requirements for sustained pressure test. Joint specimens shall not fail within these time periods. Any failures within these time periods must be of the pipe, independent of the fitting or joint and must be of a "brittle" type pipe failure, not "ductile." If ductile pipe failures occur, reduce the pressure of the test and repeat until the required results or pipe brittle failures are achieved. If test conditions are not specified by the controlling pipe standard, the requirements of **Table 2** shall be used for the pipe material type being tested with the electrofusion fitting.

9.2.3 Failure of the fitting or joint shall constitute specimen failure.

9.2.4 Failure of any one of the four specimens shall constitute failure of the test. Failure of one of the four specimens tested is cause for retest of four additional specimens, joined at the failed-specimens-joining temperature. Failure of any of these four additional specimens constitutes a failure of the test.

9.3 *Tensile Strength Test:*

9.3.1 Select four fittings at random and prepare specimens in accordance with Section 8 with the exception that it is permissible, on pipe sizes above 4 in. (102 mm) IPS, if limits of tensile machine will not allow 25 % elongation with pipe specimens of three-pipe diameters, to test with free pipe lengths of 20 in. (304-mm) minimum. From the four specimens, condition two specimens each in accordance with 8.1.1 and 8.1.2.

9.3.2 Test the specimens using the apparatus of Test Method **D638**. Test at a pull rate of 0.20 in. (5.0 mm) per min, $\pm 25\%$.

9.3.3 Failure of the fitting or joint as defined in 5.3, shall constitute specimen failure.

9.3.4 Failure of any one of the four specimens shall constitute failure of the test. Failure of one of the four specimens tested is cause for retest of four additional specimens, joined at the failed specimens joining temperature. Failure of any of these four additional specimens constitutes a failure of the test.

9.4 *Joint Integrity Tests*—Illustrations of joint crush tests for socket type joints and saddles are offered in 9.4.1 and 9.4.2 as test methods that are useful as an evaluation of bonding strength between the pipe and fitting. Alternately, the fusion evaluation test (FET) offered in 9.4.3 and 9.4.4 may be used in lieu of the crush test. Similar test evaluations as specified in the contract or purchase order and as agreed upon by the purchaser and manufacturer are of equal value in performing such evaluations and may be substituted with such agreement.