



## Designation: ~~E1030–05 (Reapproved 2011)~~ E1030/E1030M – 15

# Standard Test Method Practice for Radiographic Examination of Metallic Castings<sup>1</sup>

This standard is issued under the fixed designation ~~E1030~~E1030/E1030M; the number immediately following the designation indicates the year of original adoption or, in the case of revision, the year of last revision. A number in parentheses indicates the year of last reapproval. A superscript epsilon ( $\epsilon$ ) indicates an editorial change since the last revision or reapproval.

## 1. Scope

1.1 This test method<sup>2</sup> provides a uniform procedure for radiographic examination of metallic castings using radiographic film as the recording medium.

1.2 Due to the many complex geometries and part configurations inherent with cast products, it is necessary to recognize potential limitations associated with obtaining complete radiographic coverage on castings. Radiography of areas where geometry or part configuration does not allow achievement of complete coverage with practical radiographic methods shall be subject to mutual agreements between purchaser and supplier. The use of alternative nondestructive methods for areas that are not conducive to practical radiography shall also be specifically agreed upon between purchaser and supplier.

1.3 The radiographic method is highly sensitive to volumetric discontinuities that displace a detectable volume of cast material. Discontinuities that do not displace an appreciable volume of material, however, such as cracks or other planar-type indications, may not be detected with radiography unless the radiation beam is coincidentally aligned with the planar orientation of the discontinuity. In view of this limitation, it may be considered appropriate to use the radiographic method in conjunction with additional nondestructive methods that maintain reliable detection capabilities for these types of discontinuities. The use of additional methods shall be specifically agreed upon between the purchaser and supplier.

1.4 The radiographic techniques stated herein provide adequate assurance for defect detectability; however, it is recognized that, for special applications, specific techniques using more or less stringent requirements may be required than those specified. In these cases, the use of alternate radiographic techniques shall be as agreed upon between purchaser and supplier (also see Section 5).

1.5 The values stated in inch-pound units are to be regarded as standard.

1.6 *This standard does not purport to address all of the safety concerns, if any, associated with its use. It is the responsibility of the user of this standard to establish appropriate safety and health practices and determine the applicability of regulatory limitations prior to use.*

## 2. Referenced Documents

### 2.1 ASTM Standards:<sup>3</sup>

~~E94 Guide for Radiographic Examination~~

~~E155 Reference Radiographs for Inspection of Aluminum and Magnesium Castings~~

~~E186 Reference Radiographs for Heavy-Walled (2 to 4½ in. (50.8 to 114 mm)) Steel Castings~~

~~E192 Reference Radiographs of Investment Steel Castings for Aerospace Applications~~

~~E272 Reference Radiographs for High-Strength Copper-Base and Nickel-Copper Alloy Castings~~

~~E280 Reference Radiographs for Heavy-Walled (4½ to 12 in. (114 to 305 mm)) Steel Castings~~

~~E310 Reference Radiographs for Tin Bronze Castings~~

~~E446 Reference Radiographs for Steel Castings Up to 2 in. (50.8 mm) in Thickness~~

~~E505 Reference Radiographs for Inspection of Aluminum and Magnesium Die Castings~~

~~E543 Specification for Agencies Performing Nondestructive Testing~~

~~E689 Reference Radiographs for Ductile Iron Castings~~

<sup>1</sup> This test method practice is under the jurisdiction of ASTM Committee E07 on Nondestructive Testing and is the direct responsibility of Subcommittee E07.01 on Radiology (X and Gamma) Method.

Current edition approved Jan. 1, 2014/Dec. 1, 2015. Published March 2014/January 2016. Originally approved in 1984. Last previous edition approved in 2005/2011 as E1030–05-E1030–05(2011). DOI: 10.1520/E1030-05R11-10.1520/E1030\_E1030M-15.

<sup>2</sup> For ASME Boiler and Pressure Vessel Code applications see related Test Method SE-1030 in Section II of that Code.

<sup>3</sup> For referenced ASTM standards, visit the ASTM website, www.astm.org, or contact ASTM Customer Service at service@astm.org. For Annual Book of ASTM Standards volume information, refer to the standard's Document Summary page on the ASTM website.



~~E747 Practice for Design, Manufacture and Material Grouping Classification of Wire Image Quality Indicators (IQI) Used for Radiology~~

~~E802 Reference Radiographs for Gray Iron Castings Up to 4½ in. (114 mm) in Thickness~~

~~E999 Guide for Controlling the Quality of Industrial Radiographic Film Processing~~

~~E1025 Practice for Design, Manufacture, and Material Grouping Classification of Hole-Type Image Quality Indicators (IQI) Used for Radiology~~

~~E1079 Practice for Calibration of Transmission Densitometers~~

~~E1254 Guide for Storage of Radiographs and Unexposed Industrial Radiographic Films~~

~~E1316 Terminology for Nondestructive Examinations~~

~~E1320 Reference Radiographs for Titanium Castings~~

~~E1815 Test Method for Classification of Film Systems for Industrial Radiography~~

~~2.2 ASNT/ANSI Standards:~~

~~SNT-TC-1A Recommended Practice for Personnel Qualification and Certification in Nondestructive Testing<sup>4</sup>~~

~~CP-189 Qualification and Certification of Nondestructive Testing Personnel<sup>4</sup>~~

~~2.3 Other Standards:~~

~~NAS 410 National Aerospace Standard Certification and Qualification of Nondestructive Test Personnel<sup>5</sup>~~

~~CEN 444 Non-Destructive Testing-General Principles for Radiographic Examination of Metallic Materials by X-and Gamma-rays~~

~~ISO 5579 Non-Destructive Testing-Radiographic Examination of Metallic Materials by X-and Gamma-rays—Basic Rules~~

### ~~3. Terminology~~

~~3.1 Definitions—For definitions of terms used in this test method, see Terminology E1316.~~

### ~~4. Significance and Use~~

~~4.1 The requirements expressed in this test method are intended to control the quality of the radiographic images, to produce satisfactory and consistent results, and are not intended for controlling the acceptability or quality of materials or products.~~

### ~~5. Basis of Application~~

~~5.1 The following items shall be agreed upon by the purchaser and supplier:~~

~~5.1.1 Nondestructive Testing Agency Evaluation—If specified in the contractual agreement, nondestructive testing (NDT) agencies shall be qualified and evaluated in accordance with Practice E543. The applicable version of Practice E543 shall be specified in the contractual agreement.~~

~~5.1.2 Personnel Qualification—NDT personnel shall be qualified in accordance with a nationally recognized NDT personnel qualification practice or standard such as ANSI/ASNT CP-189, SNT-TC-1A, NAS 410, or a similar document. The practice or standard used and its applicable revision shall be specified in the contractual agreement between the using parties.~~

~~5.1.3 Apparatus—General requirements (see 6.1 through 6.9) shall be specified.~~

~~5.1.4 Requirements—General requirements (see 8.1, 8.2, 8.5, and 8.7.4) shall be specified.~~

~~5.1.5 Procedure Requirements (see 9.1, 9.1.1, 9.3, 9.7.4, and 9.7.7) shall be specified.~~

~~5.1.6 Records—Record retention (see 12.1) shall be specified.~~

### ~~6. Apparatus~~

~~6.1 Radiation Sources:~~

~~6.1.1 X Radiation Sources—Selection of appropriate X-ray voltage and current levels is dependent upon variables regarding the specimen being examined (material type and thickness) and economically permissible exposure time. The suitability of these X-ray parameters shall be demonstrated by attainment of required penetrometer (IQI) sensitivity and compliance with all other requirements stipulated herein. Guide E94 contains provisions concerning exposure calculations and charts for the use of X-ray sources.~~

~~6.1.2 Gamma Radiation Sources—Isotope sources, when used, shall be capable of demonstrating the required radiographic sensitivity.~~

~~6.2 Film Holders and Cassettes—Film holders and cassettes shall be light-tight and shall be handled properly to reduce the likelihood that they may be damaged. They may be flexible vinyl, plastic, or any durable material; or, they may be made from metallic materials. In the event that light leaks into the film holder and produces images on the film extending into the area of interest, the film shall be rejected. If the film holder exhibits light leaks, it shall be repaired before reuse or discarded. Film holders and cassettes should be routinely examined to minimize the likelihood of light leaks.~~

<sup>4</sup> Available from the American Society for Nondestructive Testing, (ASNT), 1711 Arlingate Plaza, P.O. Box 28518, Columbus, OH 43228.

<sup>5</sup> Available from Aerospace Industries Association of America, Inc., 1250 Eye Street NW, Washington, DC 20005-1000 Wilson Blvd Suite 1700, Arlington, VA 22209-3928.

6.3 Intensifying Screens:

6.3.1 Lead-Foil Screens:

6.3.1.1 Intensifying screens of the lead-foil type are generally used for all production radiography. Lead-foil screens shall be of the same approximate area dimensions as the film being used and they shall be in direct contact with the film during exposure.

6.3.1.2 Unless otherwise specified in the purchaser-supplier agreement or within the footnotes below Table 1, the lead foil screens in this table shall be used.

6.3.1.3 Sheet lead, with or without backing, used for screens should be visually examined for dust, dirt, oxidation, cracking or creasing, foreign material or other condition that could render undesirable nonrelevant images on the film.

6.3.2 Fluorescent, Fluorometallic, or Other Metallic Screens:

6.3.2.1 Fluorescent, fluorometallic, or other metallic screens may be used. However, they must be capable of demonstrating the required penetrometer (IQI) sensitivity. Fluorescent or fluorometallic screens may cause limitations in image quality (see Test Method E94, Appendix X1.)

6.3.2.2 Screen Care—All screens should be handled carefully to avoid dents, scratches, grease, or dirt on active surfaces. Screens that render false indications on radiographs shall be discarded or reworked to eliminate the artifact.

6.3.3 Other Screens—European Standard CEN 444 contains similar provisions for intensifying screens as this test method. International users of these type screens who prefer the use of CEN 444 or ISO 5579 for their particular applications should specify such alternate provisions within separate contractual arrangements from this test method.

6.4 Filters—Filters shall be used whenever the contrast reductions caused by low-energy scattered radiation or the extent of undercut and edge burn-off occurring on production radiographs is of significant magnitude so as to cause failure to meet the quality level or radiographic coverage requirements stipulated by the job order or contract (see Guide E94).

6.5 Masking—Masking material may be used, as necessary, to help reduce image degradation due to undercutting (see Guide E94).

6.6 Penetrators (IQI)—Unless otherwise specified by the applicable job order or contract, only those penetrators that comply with the design and identification requirements specified in Practice E747 or Practice E1025 shall be used.

6.7 Shims and Separate Blocks—Shims or separate blocks made of the same or radiographically similar materials (as defined in Method E1025) may be used to facilitate penetrator positioning. There is no restriction on shim or separate block thickness provided the penetrator and area-of-interest density tolerance requirements of 9.7.6.2 are met.

6.8 Radiographic Location and Identification Markers—Lead numbers and letters are used to designate the part number and location number. The size and thickness of the markers shall depend on the ability of the radiographic technique to image the

ASTM E1030/E1030M-15

<https://standards.iteh.ai/catalog/standards/sist/67a-9008761-dcf17/astm-e1030-e1030m-15>

TABLE 1 Lead Foil Screens

keV Range	Front Screen <sup>A</sup>	Back Screen Minimum
0 to 150 keV <sup>B</sup>	0.000 to 0.001 in. (0 to 0.025 mm)	0.005 in. (0.127 mm)
150 to 200 keV; Ir-192, Se-75	0.000 to 0.005 in. (0 to 0.127 mm)	0.005 in. (0.127 mm) <sup>C</sup>
200 keV to 2 MeV; Co-60	0.005 to 0.010 in. (0.126 to 0.254 mm)	0.010 in. (0.254 mm)
2 to 4 MeV	0.010 to 0.020 in. (0.254 to 0.508 mm)	0.010 in. (0.254 mm)
4 to 10 MeV	0.010 to 0.030 in. (0.254 to 0.762 mm)	0.010 in. (0.254 mm)
10 to 25 MeV	0.010 to 0.050 in. (0.254 to 1.27 mm)	0.010 in. (0.254 mm)

TABLE 1 Lead Foil Screens<sup>A</sup>

Energy Range/Isotope	Front Screen, in. <sup>A</sup>	Back Screen Minimum, in.	Front and Back Screens, mm <sup>B</sup>
0 to 150 keV <sup>C</sup>	0.000 to 0.001	0.005 <sup>D</sup>	0 to 0.15
151 to 200 keV	0.000 to 0.005	0.005 <sup>D</sup>	0 to 0.15
201 to 320 keV	0.001 to 0.010	0.005	0.02 to 0.2
Se-75	0.001 to 0.010	0.005	0.1 to 0.2
321 to 450 keV	0.05 to 0.015	0.010	0.1 to 0.2
Ir-192	0.05 to 0.015	0.010	0.02 to 0.2
451 keV to 2 MeV	0.05 to 0.020	0.010	0.1 to 0.5
Co-60	0.05 to 0.020	0.010	0.1 to 0.5
2 to 4 MeV	0.010 to 0.020	0.010	0.1 to 0.5
4 to 10 MeV	0.010 to 0.030	0.010	0.5 to 1.0
10 to 25 MeV	0.010 to 0.050	0.010	1.0 to 2.0

<sup>A</sup>The lead screen thickness listed for the various voltage ranges are recommended thicknesses and not required thicknesses. Other thicknesses and materials may be used provided the required radiographic quality level, contrast, and density are achieved.

<sup>B</sup>Lead screen thicknesses in accordance with ISO 5579 in SI units. For energy ranges of Co-60 and 451 keV to 4 MeV, steel or copper screens of 0.1 to 0.5 mm may be used. For energy ranges above 4 MeV to 10 MeV, 0.5 to 1.0 mm steel or copper or up to 0.5 mm tantalum screens are recommended. Additional back scatter shielding may be achieved by additional lead screen behind the cassettes.

<sup>C</sup>Prepacked film with lead screens may be used from 80 to 150 keV. No lead screens are recommended below 80 keV. Prepackaged film may be used at higher energy levels provided the contrast, density, radiographic quality level, and backscatter requirements are achieved. Additional intermediate lead screens may be used for reduction of scattered radiation at higher energies.

<sup>D</sup>No back screen is required provided the backscatter requirements of 9.5 are met.

markers on the radiograph. As a general rule, markers 1/16-in. (1.58-mm) thick will suffice for most low-energy (less than 1 MeV) X-ray and Iridium-192 radiography; for higher-energy radiography it may be necessary to use markers that are 1/8-in. (3.17-mm) or more thick.

**6.9 Radiographic Density Measurement Apparatus**—Either a transmission densitometer or a step-wedge comparison film shall be used for judging film density requirements. Step wedge comparison films or densitometer calibration, or both, shall be verified by comparison with a calibrated step-wedge film traceable to the National Institute of Standards and Technology. Densitometers shall be calibrated in accordance with Practice **E1079**.

## 7. Reagents and Materials

**7.1 Film Systems**—Only film systems having cognizant engineering organization (CEO) approval or meeting the requirements of Test Method **E1815** shall be used to meet the requirements of this test method.

## 8. Requirements

**8.1 Procedure Requirement**—Unless otherwise specified by the applicable job order or contract, radiographic examination shall be performed in accordance with a written procedure. Specific requirements regarding the preparation and approval of written procedures shall be dictated by a purchaser and supplier agreement. The procedure details should include at least those items stipulated in **Appendix X1**. In addition, a radiographic standard shooting sketch (RSS), **Fig. X1.1**, shall be prepared similar to that shown in **Appendix X1** and shall be available for review during interpretation of the film.

**8.2 Radiographic Coverage**—Unless otherwise specified by a purchaser and supplier agreement, the extent of radiographic coverage shall be the maximum practical volume of the casting. Areas that require radiography shall be designated as illustrated in **Figs. X1.2 and X1.3** of **Appendix X1**. When the shape or configuration of the casting is such that radiography is impractical, these areas shall be so designated on drawings or sketches that accompany the radiographs. Examples of casting geometries and configurations that may be considered impractical to radiograph are illustrated in **Appendix X2**.

**8.3 Radiographic Film Quality**—All radiographs shall be free of mechanical, chemical, handling-related, or other blemishes which could mask or be confused with the image of any discontinuity in the area of interest on the radiograph. If any doubt exists as to the true nature of an indication exhibited by the film, the radiograph shall be retaken or rejected.

**8.4 Radiographic Quality Level**—The applicable job order or contract shall dictate the requirements for radiographic quality level. (See Practice **E1025** or Practice **E747** for guidance in selection of quality level.)

**8.5 Acceptance Level**—Radiographic acceptance levels and associated severity levels shall be stipulated by the applicable contract, job order, drawing, or other purchaser and supplier agreement.

**8.6 Radiographic Density Limitations**—Radiographic density in the area of interest shall be within 1.5 to 4.0 for either single or superimposed viewing.

### 8.7 Film Handling:

**8.7.1 Darkroom Facilities**—Darkroom facilities should be kept clean and as dust-free as practical. Safelights should be those recommended by film manufacturers for the radiographic materials used and should be positioned in accordance with the manufacturer's recommendations. All darkroom equipment and materials should be capable of producing radiographs that are suitable for interpretation.

**8.7.2 Film Processing**—Radiographic film processing shall be controlled in accordance with Guide **E999**.

**8.7.3 Film Viewing Facilities**—Viewing facilities shall provide subdued background lighting of an intensity that will not cause troublesome reflections, shadows, or glare on the radiograph. The viewing light shall be of sufficient intensity to review densities up to 4.0 and be appropriately controlled so that the optimum intensity for single or superimposed viewing of radiographs may be selected.

**8.7.4 Storage of Radiographs**—When storage is required by the applicable job order or contract, the radiographs should be stored in an area with sufficient environmental control to preclude image deterioration or other damage. The radiograph storage duration and location after casting delivery shall be as agreed upon between purchaser and supplier. (See Guide **E1254** for storage information.)

## 9. Procedure

**9.1 Time of Examination**—Unless otherwise specified by the applicable job order or contract, radiography may be performed prior to heat treatment and in the as-cast, rough-machined, or finished-machined condition.

**9.1.1 Penetrator (IQI) Selection**—Unless otherwise specified in the applicable job order or contract, penetrator (IQI) selection shall be based on the following: if the thickness to be radiographed exceeds the design thickness of the finished piece, the penetrator (IQI) size shall be based on a thickness which does not exceed the design thickness of the finished piece by more than 20 % or 1/4 in. (6.35 mm), whichever is greater. In no case shall the penetrator (IQI) size be based on a thickness greater than the thickness to be radiographed.

**9.2 Surface Preparation**—The casting surfaces shall be prepared as necessary to remove any conditions that could mask or be confused with internal casting discontinuities.

**9.3 Source-to-Film Distance**—Unless otherwise specified in the applicable job order or contract, geometric unsharpness ( $U_g$ ) shall not exceed the following in **Table 2**.

**9.4 Direction of Radiation**—The direction of radiation shall be governed by the geometry of the casting and the radiographic coverage and quality requirements stipulated by the applicable job order or contract. Whenever practicable, place the central beam of the radiation perpendicular to the surface of the film. **Appendix X2** provides examples of preferred source and film orientations and examples of casting geometries and configurations on which radiography is impractical or very difficult.

**9.5 Back-Scattered Radiation Protection:**

**9.5.1 Back-Scattered Radiation**—(secondary radiation emanating from surfaces behind the film, that is, walls, floors, etc.) serves to reduce radiographic contrast and may produce undesirable effects on radiographic quality. A 1/8-in. (3.17-mm) lead sheet placed behind the film generally furnishes adequate protection against back-scattered radiation.

**9.5.2** To detect back-scattered radiation, position a lead letter “B” (approximately 1/8-in. (3.17-mm) thick by 1/2-in. (12.7-mm) high) on the rear side of the film holder. If a light image (lower density) of the lead letter “B” appears on the radiograph, it indicates that more back-scatter protection is necessary. The appearance of a dark image of the lead letter “B” should be disregarded unless the dark image could mask or be confused with rejectable casting defects.

**9.6 Penetrameter (IQI) Placement**—Place all penetrameters (IQI) being radiographed on the source side of the casting. Place penetrameters (IQI) in the radiographic area of interest, unless the use of a shim or separate block is necessary, as specified in **9.7.6**.

**9.7 Number of Penetrameters (IQI):**

**9.7.1** One penetrameter (IQI) shall represent an area within which radiographic densities do not vary more than +30 % to –15 % from the density measured through the body of the penetrameter (IQI).

**9.7.2** When the film density varies more than –15 % to +30 %, two penetrameters (IQI) shall be used as follows: if one penetrameter (IQI) shows acceptable sensitivity representing the most dense portion of the exposure, and the second penetrameter (IQI) shows acceptable sensitivity representing the least dense portion of the exposure, then these two penetrameters (IQI) shall qualify the exposure location within these densities, provided the density requirements stipulated in **8.6** are met.

**9.7.3** For cylindrical or flat castings where more than one film holder is used for an exposure, at least one penetrameter (IQI) image shall appear on each radiograph. For cylindrical shapes, where a panoramic type source of radiation is placed in the center of the cylinder and a complete or partial circumference is radiographed using at least four overlapped film holders, at least three penetrameters (IQI) shall be used. On partial circumference exposures, a penetrameter (IQI) shall be placed at each end of the length of the image to be evaluated on the radiograph with the intermediate penetrameters (IQI) placed at equal divisions of the length covered. For full circumferential coverage, three penetrameters (IQI) spaced 120° apart shall be used, even when using a single length of roll film.

**9.7.4** When an array of individual castings in a circle is radiographed, the requirements of **9.7.1** or **9.7.2**, or both, shall prevail for each casting.

**9.7.5** If the required penetrameter (IQI) sensitivity does not show on any one film in a multiple film technique (see **9.11**), but does show in composite (superimposed) film viewing, interpretation shall be permitted only by composite film viewing for the respective area.

**9.7.6** When it is not practicable to place the penetrameter(s) (IQI) on the casting, a shim or separate block conforming to the requirements of **6.7** may be used.

**9.7.6.1** The penetrameter (IQI) shall be no closer to the film than the source side of that part of the casting being radiographed in the current view.

**9.7.6.2** The radiographic density measured adjacent to the penetrameter (IQI) through the body of the shim or separate block shall not exceed the density measured in the area of interest by more than 15 %. The density may be lighter than the area of interest density, provided acceptable quality level is obtained and the density requirements of **8.6** are met.

**TABLE 2 Source-to-Film Distance Unsharpness ( $U_g$ ) Maximum**

Material Thickness	$U_g$ Maximum <sup>A</sup>
Under 1 in. (25.4 mm)	0.010 in. (0.254 mm)
Under 1 in. [25.4 mm]	0.010 in. [0.25 mm]
1 through 2 in. (25.4 through 50.8 mm)	0.020 in. (0.508 mm)
1 through 2 in. [25.4 through 51 mm]	0.020 in. [0.50 mm]
Over 2 through 3 in. (over 50.8 through 76.2 mm)	0.030 in. (0.762 mm)
Over 2 through 3 in. [over 51 through 76.0 mm]	0.030 in. [0.76 mm]
Over 3 through 4 in. (over 76.2 through 101.6 mm)	0.040 in. (1.016 mm)
Over 3 through 4 in. [over 76.0 through 100 mm]	0.040 in. [1.00 mm]
Greater than 4 in. (greater than 101.6 mm)	0.070 in. (1.778 mm)
Greater than 4 in. [greater than 100 mm]	0.070 in. [1.78 mm] <sup>B</sup>

<sup>A</sup>Geometric unsharpness values shall be determined (calculated) as specified by the formula in Guide **E94**.

<sup>B</sup>The geometric unsharpness should be reduced to 0.050 in. [1.27 mm] if the required IQI sensitivity is not achieved.



9.7.6.3 The shim or separate block shall be placed at the corner of the film holder or close to that part of the area of interest that is furthest from the central beam. This is the worst case position from a beam angle standpoint that a discontinuity would be in.

9.7.6.4 The shim or separate block dimensions shall exceed the penetrameter (IQI) dimensions such that the outline of at least three sides of the penetrameter (IQI) image shall be visible on the radiograph.

9.7.7 *Film Side Penetrameter (IQI)*—In the case where the penetrameter (IQI) cannot be physically placed on the source side and the use of a separate block technique is not practical, penetrameters (IQI) placed on the film side may be used. The applicable job order or contract shall dictate the requirements for film side radiographic quality level (see 8.4).

9.8 *Location Markers*—The radiographic image of the location markers for the coordination of the casting with the film shall appear on the film, without interfering with the interpretation, in such an arrangement that it is evident that the required coverage was obtained. These marker positions shall be marked on the casting and the position of the markers shall be maintained on the part during the complete radiographic cycle. The RSS shall show all marker locations.

9.9 *Radiographic Identification*—A system of positive identification of the film shall be used and each film shall have a unique identification relating it to the item being examined. As a minimum, the following additional information shall appear on each radiograph or in the records accompanying each radiograph:

- (1) Identification of organization making the radiograph,
- (2) Date of exposure,
- (3) Identification of the part, component or system and, where applicable, the weld joint in the component or system, and
- (4) Whether the radiograph is an original or repaired area.

9.10 *Subsequent Exposure Identification*—All repair radiographs after the original (initial) shall have an examination status designation that indicates the reason. Subsequent radiographs made by reason of a repaired area shall be identified with the letter “R” followed by the respective repair cycle (that is, R-1 for the first repair, R-2 for the second repair, etc.). Subsequent radiographs that are necessary as a result of additional surface preparation should be identified by the letters “REG.”

9.11 *Multiple Film Techniques*—Two or more films of equal or different speeds in the same cassette are allowed, provided prescribed quality level and density requirements are met (see 9.7.2 and 9.7.5).

9.12 *Radiographic Techniques:*

9.12.1 *Single Wall Technique*—Except as provided in 9.12.2, radiography shall be performed using a technique in which the radiation passes through only one wall.

9.12.2 *Double Wall Technique*—For castings with an inside diameter of 4 in. or less, a technique may be used in which the radiation passes through both walls and both walls are viewed for acceptance on the same film. An adequate number of exposures shall be taken to ensure that required coverage has been obtained.

9.13 *Safety*—Radiographic procedures shall comply with applicable city, state, and federal regulations.

## 10. Radiograph Evaluation

10.1 *Film Quality*—Verify that the radiograph meets the quality requirements specified in 8.3, 8.4, 8.6, 9.5.2 and 9.7.

10.2 *Film Evaluation*—Determine the acceptance or rejection of the casting by comparing the radiographic image to the agreed upon acceptance criteria (see 8.5).

## 11. Reference Radiographs

11.1 Reference Radiographs E155, E186, E192, E272, E280, E310, E446, E505, E689, E802, and E1320 are graded radiographic illustrations of various casting discontinuities. These reference radiographs may be used to help establish acceptance criteria and may also be useful as radiographic interpretation training aids.

## 12. Report

12.1 The following radiographic records shall be maintained as agreed upon between purchaser and supplier:

12.1.1 Radiographic standard shooting sketch;

12.1.2 Weld repair documentation;

12.1.3 Film;

12.1.4 Film interpretation record containing as a minimum:

12.1.4.1 Disposition of each radiograph (acceptable or rejectable);

12.1.4.2 If rejectable, cause for rejection (shrink, gas, etc.);

12.1.4.3 Surface indication verified by visual examination (mold, marks, etc.); and

12.1.4.4 Signature of the film interpreter.



### 13. Precision and Bias

13.1 No statement has been made about either the precision or bias of this test method since the result merely states whether there is conformance to the criteria for success specified in the procedure.

### 14. Keywords

14.1 castings; gamma-ray; nondestructive testing; radiographic; radiography; X-ray

## APPENDIXES

### (Nonmandatory Information)

#### X1. RADIOGRAPHIC STANDARD SHOOTING SKETCH (RSS)

X1.1 The radiographic standard shooting sketch (RSS) provides the radiographic operator and the radiographic interpreter with pertinent information regarding the examination of a casting. The RSS is designed to standardize radiographic methodologies associated with casting examination; it may also provide a means of a purchaser and supplier agreement, prior to initiation of the examination on a production basis. The use of a RSS is advantageous due to the many configurations associated with castings and the corresponding variations in techniques for examination of any particular one. The RSS provides a map of location marker placement, directions for source and film arrangement, and instructions for all other parameters associated with radiography of a casting. This information serves to provide the most efficient method for controlling the quality and consistency of the resultant radiographic representations.

X1.2 The RSS usually consists of an instruction sheet and sketch(es) of the casting; the instruction sheet specifies the radiographic equipment, materials, and technique-acceptance parameters for each location; the sketch(es) illustrate(s) the location, orientation, and the source and film arrangement for each location. Figs. X1.1-X1.3 of this appendix provide a typical instruction sheet and sketch sheets. As a minimum, the RSS should provide the following information. All spaces shall be filled in unless not applicable; in those cases, the space shall be marked NA.

X1.2.1 The instruction sheet should provide the following:

X1.2.1.1 Company preparing RSS and activity performing radiography.

X1.2.1.2 Casting identification including:

- (1) Drawing number;
- (2) Casting identification number;
- (3) Descriptive name (for example, pump casting, valve body, etc.);
- (4) Material type and material specification;
- (5) Heat number, and
- (6) Pattern number.

X1.2.1.3 Surface condition at time of radiography (as cast, rough machined, finished machined).

X1.2.1.4 Spaces for approval (as applicable).

X1.2.1.5 *Radiographic Technique Parameters for Each Location:*

- (1) Radiographic location designation;
- (2) Source type and size;
- (3) Finished thickness;
- (4) Thickness when radiographed;
- (5) Penetrameters;
- (6) Source to film distance;
- (7) Film type and quantity;
- (8) Film size;
- (9) Required penetrometer (IQI) quality level;
- (10) Radiographic acceptance standard, and
- (11) Applicable radiographic severity level.

GENERAL INFORMATION				CASTING IDENTIFICATION			
COMPANY PREPARING RSS				DRAWING NO.		REVISION	
COMPANY PERFORMING RT				DESCRIPTION			
FOUNDRY CASTING IDENTIFICATION METHOD				MATERIAL		MATERIAL SPEC.	
STAMPED <input checked="" type="checkbox"/> ETCHED <input type="checkbox"/> AT RT LOCATION 9-10				<b>NI-CU</b>			
SURFACE CONDITION WHEN RT'D				PATTERN NO.		HEAT NO.	
AS CAST <input type="checkbox"/> ROUGH MACH'D <input checked="" type="checkbox"/> FINISH MACH'D <input type="checkbox"/>							
RSS APPROVAL							
SUPPLIER				CUSTOMER			
1.		DATE		1.		DATE	
2.		DATE		2.		DATE	
RT PARAMETERS							
VIEWS	1-2 thru 4-1	5-6 thru 7-8	9-10	11-12	13		
SOURCE TYPE	IRID <sup>192</sup>						
FINISHED THICKNESS	13/16"	3/4"	5/8"-2-1/8	5/8"-2-3/8	3/4"-2-3/8		
THICKNESS WHEN RT'D	15/16"	7/8"	3/4"-2-5/16	3/4"-2-1/2	7/8"-2-1/2		
PENETRATOR(S)	17	17	15 - 45	15 - 50	17 - 50		
SOURCE TO FILM DISTANCE	30"						
FILM TYPE	1		1 & 2				
FILM SIZE	5 X 7		8 X 10				
QUALITY LEVEL	2 - 2T						
ACCEPTANCE STANDARD	ASTM E-272						
SEVERITY LEVEL	2						
NOTES				REVISIONS			
				REV.	DESCRIPTION	APPROVAL	
						SUPPLIER BY	CUSTOMER BY
				A	ORIGINAL ISSUE	—	—
						—	—
						—	—
						—	—
RSS NO. XXX-YYY-22				REVISION A	PAGE 1	OF 3	

**FIG. X1.1 Sample Radiographic Standard Shooting Sketch (RSS)**

X1.2.2 The sketch(es) should provide the following:

X1.2.2.1 Location marker placement.

X1.2.2.2 Location of foundry's identification pad or symbol on the casting.

X1.2.2.3 Designation of areas that require radiography (as applicable).

X1.2.2.4 Designation of areas that are considered impractical or very difficult to radiograph (see 1.2 and 8.2).

X1.2.2.5 Radiographic source and film arrangement and radiation beam direction for each location.

NOTE X1.1—The RSS should designate the involved locations and stipulate that the technique for those locations is typical, for sections of the casting on which a continuing series of locations are to be radiographed with the same basic source and film arrangement for each location.

X1.2.3 Fig. X1.1 of this appendix provides a sample RSS that has been developed for a typical production application, and Figs. X1.2 and X1.3 provide sample RSS sketches that have been developed for a typical production application.

X1.2.4 The RSS may not provide what is considered to be the most effective means of technique control for all radiographic activities, but, in any event, some means of technique standardization should be employed. As a general rule, it is a beneficial practice for the supplier to solicit purchaser approval of the radiographic methodology prior to performing production radiography.



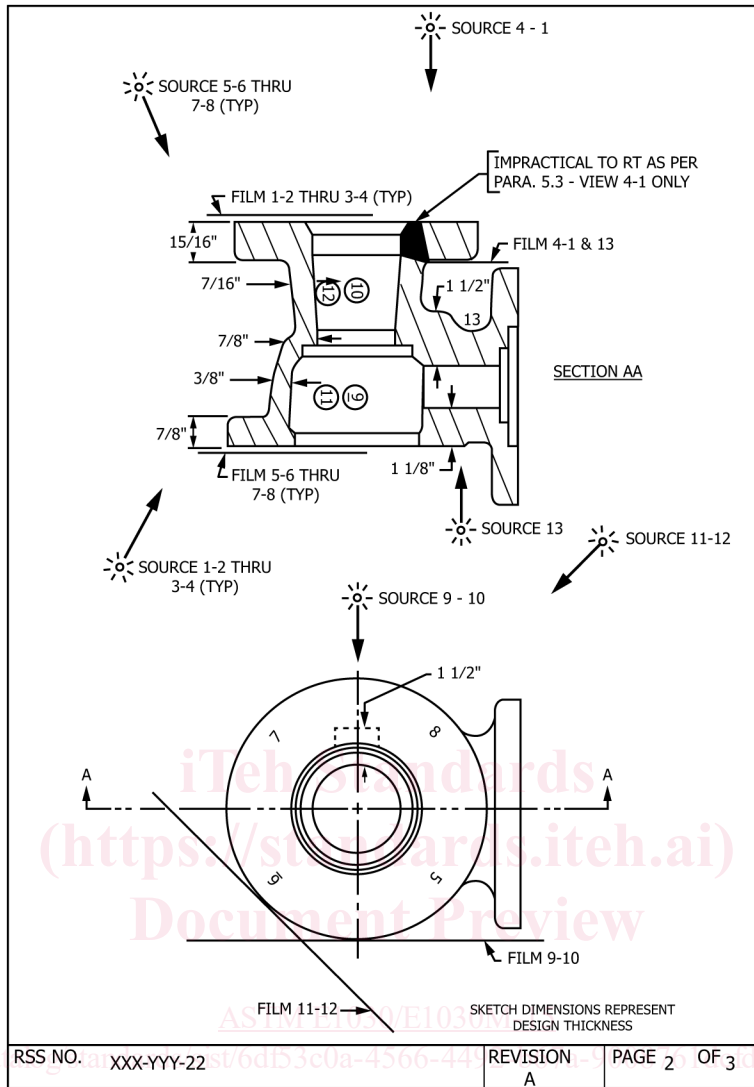

FIG. X1.2 Samples of Radiographic Standard Shooting Sketches (RSS) Views Illustrating Layout of Source and Film Placement

This generally entails the demonstration of the adequacy of the methodology by submitting the proposed technique parameters and a corresponding set of pilot radiographs to the purchaser for review. Purchaser approval of the technique shall be addressed in the applicable job order or contract.

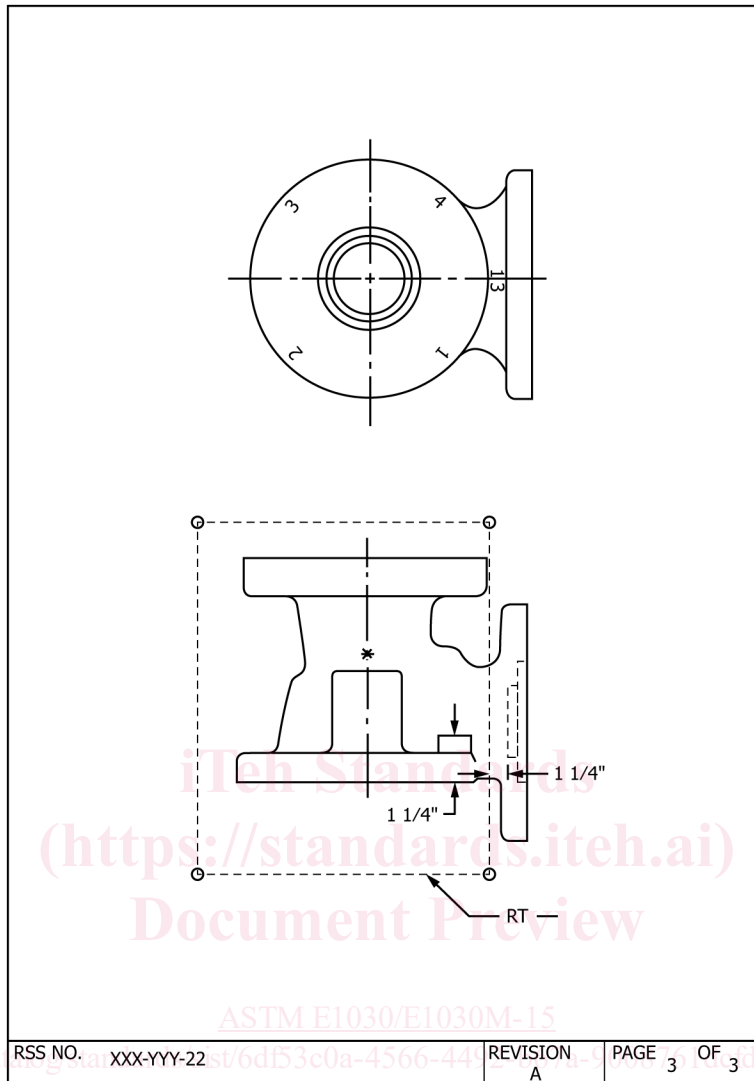

FIG. X1.3 Samples of Radiographic Standard Shooting Sketches (RSS) Views Illustrating Layout and Extent of Coverage

**X2. PREFERRED SOURCE AND FILM ALIGNMENT FOR FLANGE RADIOGRAPHY AND EXAMPLES OF AREAS THAT ARE CONSIDERED IMPRACTICAL TO RADIOGRAPH**

X2.1 Preferred Source and Film Alignment for Flange Radiography—The effective use of radiography for assessing material soundness in casting areas where a flange joins a body is somewhat limited by the source and film alignment that the geometric configuration of these areas require. The following figures (see Figs. X2.1-X2.3) describe source and film alignments that can be employed and discusses the limits and benefits of each.